IRB 5710

Large size robot for material handling,
payload from 70kg to 110kg



Faster, more robust and accurate, the IRB 5710 brings higher uptime, increased productivity, and better performance in the automotive and general industries.

ABB is expanding its large size robot portfolio with IRB 5710, offering faster performance, more accurate, expanded mounting options, and advanced foundry protection than other competing robots in its class. The IRB 5710 is available in four variants spanning various options for payload from 70kg to 110kg, reach from 2.3m to 2.7m.

IRB 5710 is ideal for use in material handling, machine tending, and high precision assembly applications in the Electric Vehicle (EV), automotive, and the general industries. For Electric Vehicles, robots can handle an array of tasks, including EV battery module picking and placing, high precision assembly, and parts handling. For general industries, the robots can be used for a wide range of tasks in die casting, material removal, cleaning, spraying, and general high precision applications.

Productivity

Thanks to the robot's robust mechanical design and OmniCore controller V250XT's motion control, the IRB 5710 provides improved speed and accuracy to help increase productivity. IRB 5710 is faster than competing robots and up to 25 percent faster than ABB's large-size robots (IRB 6700 and IRB 6620), enabling more products to be manufactured in

less time. With the excellent position repeatability, path accuracy, and path speed, IRB 5710 is more accurate than other robots, enabling the highest levels of manufacturing quality to be achieved.

LeanID Integrated DressPack increases uptime

By integrating cabling within the body of the robot, ABB's unique LeanID Integrated DressPack reduces the problem of swinging cables that can cause wear and tear, reducing downtime and maintenance cost. LeanID makes it easier to program and simulate with predictable cable movements at RobotStudio.

Flexible production layout

IRB 5710 has multiple mounting options, including floor, angled, inverted and semi shelf for maximum production layout design flexibility. IRB 5710 offers more mounting options than other robots.

Foundry protections

The robots also include superior harsh environment protection, Foundry Plus, additional sealant protection for high radiant or contact heat, ensuring higher availability, fewer breakdowns and longer equipment lifetime. The optional protection guards IRB 5710 against the harshest of foundry environments.

Key benefits

- TrueMove and QuickMove software enables best-in-class motion control and improved cycle times, and path accuracy.
- Increased speed and shorter cycle times – faster than other robots, and up to 25 percent faster than IRB 6620 and IRB 6700.
- LeanID Integrated DressPack reduces cable wear and tear, and lengthens service interval.
- Robust design with a rigid structure increases uptime.
- Multiple mounting options for flexible production layouts.
- Built to operate in harsh environments—available with Foundry Plus protection.

Specification

Robot version	Reach (m)	Handling capacity (kg)*	Center of gravity (mm)	Wrist torque (Nm)
IRB 5710-110/2.3	2.3	110	300	571
IRB 5710-90/2.7	2.7	90	200	318
IRB5710-90/2.3 LID	2.3	90	300	569
IRB 5710-70/2.7 LID	2.7	70	200	340
Number of axes	6			
Protection	IP67 Option: Foundry Plus			
Mounting	Floor, tilted max 20° Option: Inverted			
Controller	OmniCore V250XT			

* LID versions include dresspack, other versions allow 20kg extra load on upper arm

Performance (according to ISO 9283)

	Position repeatability	Path repeatability
IRB 5710-110/2.3	0.04 mm	0.12 mm
IRB 5710-90/2.7	0.05 mm	0.16 mm

Technical information

Electrical Connections

Supply voltage	380 - 480 VAC, 50/60 Hz
Energy consumption	2.3-2.9 kW

* ISO-cube at max performance depending on robot version

Physical

Robot base	1023 x 724 mm	
Robot weight	Std	Inv
3300-322 IRB 5710-110/2.3	830 kg	845 kg
3300-323 IRB 5710-90/2.7	830 kg	840 kg
3300-324 IRB 5710-90/2.3LID	890 kg	905 kg
3300-325 IRB 5710-70/2.7LID	885 kg	900 kg

Main applications

- EV Battery modules picking, placing, and high precision assembly.
- Automotive tier 1 parts material handling, and machine tending.
- General Industry material handling, machine tending, die casting, and general high precision applications.

More applications on process applications such as welding, cutting, or dispensing will be released in 2023.

Environment

Ambient temperature for mechanical unit	
During operation	+5°C (41°F) to +50°C (122°F)
During transportation and storage	-25°C (13°F) to +55°C (131°F)
During short periods (max 24 hours)	up to +70°C (158°F)
Relative humidity	Max 95%
Noise level	70 dB
Safety	Double circuits with supervision, emergency stops and safety functions, 3-position enable device
Extended safety	SafeMove
Emission	EMC/EMI-shielded

Movement

Working range	"IRB 5710-110/2.3 IRB 5710-90/2.7"	"IRB 5710-90/2.3LID IRB 5710-70/2.7LID"
Axis 1*	±170°	±170°
Axis 2	-75°/+145°	-75°/+145°
Axis 3	-180°/+70°	-160°/+70°
Axis 4	±300°	±300°
Axis 5	±130°	±120°
Axis 6	±360°	±200°

* Option ±220° working range is the same for inverted variant.

Axis max speed

	Axis 1	Axis 2	Axis 3	Axis 4	Axis 5	Axis 6
IRB 5710-110/2.3	140°/s	125°/s	140°/s	250°/s	200°/s	250°/s
IRB 5710-90/2.7	140°/s	125°/s	140°/s	300°/s	250°/s	360°/s
IRB 5710-90/2.3LID	140°/s	125°/s	140°/s	250°/s	200°/s	250°/s
IRB 5710-70/2.7LID	140°/s	125°/s	140°/s	300°/s	250°/s	360°/s

More information about the data specification is found in the Product Specification
Data and dimensions may be changed without notice

Working range IRB 5710-90/2.7

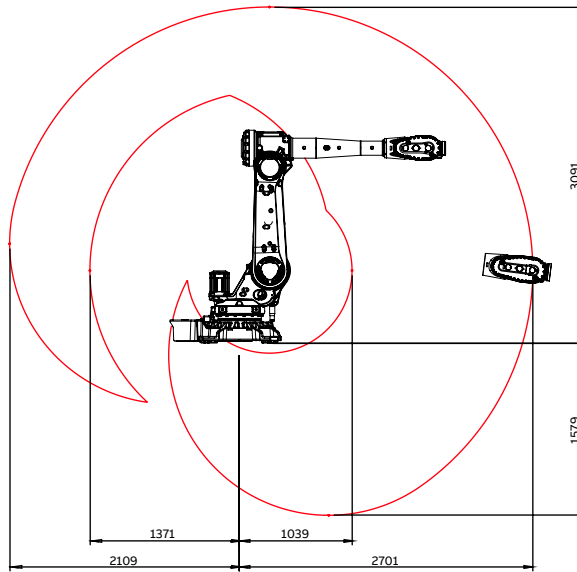

Working range IRB 5710-110/2.3

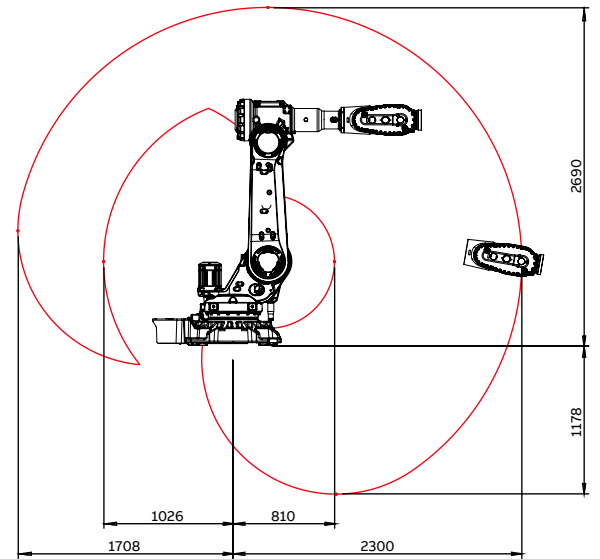

Working range IRB 5710-70/2.7 LID

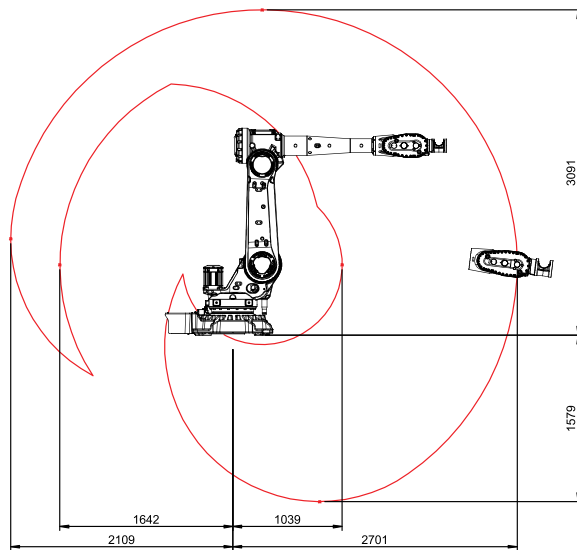

Working range IRB 5710-90/2.3 LID

