

ROBOTICS

Product manual

IRB 910INV



Trace back information:
Workspace 23B version a11
Checked in 2023-06-20
Skribenta version 5.5.019

Product manual
IRB 910INV-3/0.35
IRB 910INV-6/0.55

OmniCore

Document ID: 3HAC068055-001

Revision: P

The information in this manual is subject to change without notice and should not be construed as a commitment by ABB. ABB assumes no responsibility for any errors that may appear in this manual.

Except as may be expressly stated anywhere in this manual, nothing herein shall be construed as any kind of guarantee or warranty by ABB for losses, damage to persons or property, fitness for a specific purpose or the like.

In no event shall ABB be liable for incidental or consequential damages arising from use of this manual and products described herein.

This manual and parts thereof must not be reproduced or copied without ABB's written permission.

Keep for future reference.

Additional copies of this manual may be obtained from ABB.

Original instructions.

© Copyright 2019-2023 ABB. All rights reserved.
Specifications subject to change without notice.

Table of contents

Overview of this manual	9
Product documentation	12
How to read the product manual	14
1 Safety	15
1.1 Safety information	15
1.1.1 Limitation of liability	15
1.1.2 Requirements on personnel	16
1.2 Safety signals and symbols	17
1.2.1 Safety signals in the manual	17
1.2.2 Safety symbols on manipulator labels	19
1.3 Robot stopping functions	25
1.4 Safety during installation and commissioning	26
1.5 Safety during operation	29
1.6 Safety during maintenance and repair	30
1.6.1 Safety during maintenance and repair	30
1.6.2 Emergency release of the robot axes	33
1.6.3 Brake testing	34
1.7 Safety during troubleshooting	35
1.8 Safety during decommissioning	36
2 Manipulator description	37
2.1 Technical data	37
2.2 Robot dimensions	41
2.3 Working range	43
2.4 Information labels	44
2.5 The unit is sensitive to ESD	45
3 Installation and commissioning	47
3.1 Introduction to installation and commissioning	47
3.2 Unpacking	48
3.2.1 Pre-installation procedure	48
3.2.2 Risk of tipping/stability	49
3.2.3 Transportation bracket	53
3.3 On-site installation	56
3.3.1 Test run after installation, maintenance, or repair	56
3.3.2 Lifting the robot	57
3.3.2.1 Lifting the robot by two people	57
3.3.2.2 Lifting robot with lifting accessories	59
3.3.2.3 Lifting and rotating a suspended mounted or tilted manipulator	64
3.3.3 Manually releasing the brakes	65
3.3.4 Orienting and securing the robot	68
3.3.5 Loads fitted to the robot, stopping time and braking distances	70
3.3.6 Lamp	71
3.3.6.1 Lamp on the robot	71
3.3.6.2 Installation of signal lamp (option)	72
3.3.7 Fitting equipment on the robot (robot dimensions)	74
3.4 Restricting the working range	82
3.4.1 Adjusting the working range	82
3.4.2 Mechanically restricting the working range	83
3.5 Electrical connections	84
3.5.1 Robot cabling and connection points	84
3.5.2 Customer connections	87
3.6 Start of robot in cold environments	89
3.7 Test run after installation, maintenance, or repair	90

Table of contents

4	Maintenance	91
4.1	Introduction	91
4.2	Service Information System (SIS)	92
4.3	Maintenance schedule and expected component life	93
4.3.1	Specification of maintenance intervals	93
4.3.2	Maintenance schedule	94
4.3.3	Expected component life	96
4.4	Cleaning activities	97
4.4.1	Cleaning the IRB 910INV	97
4.5	Inspection activities	99
4.5.1	Inspecting the information labels	99
4.5.2	Inspecting the robot cabling	101
4.5.3	Inspecting the ball screw spline unit	102
4.5.4	Inspecting axis-3 mechanical stops	105
4.5.5	Inspecting the bellows	108
4.5.6	Inspecting timing belts	111
4.6	Lubrication activities	114
4.6.1	Lubricating the ball screw spline unit	114
4.7	Replacement/changing activities	116
5	Repair	117
5.1	Introduction	117
5.2	General procedures	118
5.2.1	Cut the paint or surface on the robot before replacing parts	118
5.3	Cable harness	120
5.3.1	Replacing the base harness	120
5.3.2	Replacing the internal harness	136
5.3.3	Replacing the process hub	189
5.3.4	Replacing the SMB unit and battery unit	214
5.4	Base	225
5.4.1	Replacing the base	225
5.4.2	Replacing the axis-1 timing belt	253
5.5	Inner arm	278
5.5.1	Replacing the inner arm	278
5.5.2	Replacing the axis-2 timing belt	345
5.6	Outer arm	377
5.6.1	Replacing the mechanical stopper	377
5.6.2	Replacing the bellows	403
5.6.3	Replacing the pulley on the ball screw upper position	425
5.6.4	Replacing the pulley on the ball screw lower position	444
5.6.5	Replacing the ball screw	464
5.6.6	Replacing the axis-3 timing belt	503
5.6.7	Replacing the axis-4 second timing belt	513
5.6.8	Replacing the axis-4 timing belt	525
5.6.9	Replacing the pulley pre-assembly	543
5.6.10	Replacing the outer arm	562
5.7	Motors	624
5.7.1	Replacing the axis-1 motor sub-assembly	624
5.7.2	Replacing the axis-2 motor sub-assembly	649
5.7.3	Replacing the axis-3 motor sub-assembly	661
5.7.4	Replacing the axis-4 motor sub-assembly	681
5.8	Gearboxes	700
5.8.1	Replacing the axis-1 gear unit sub-assembly	700
5.8.2	Replacing the axis-2 gear unit sub-assembly	733
6	Calibration	771
6.1	Introduction to calibration	771
6.1.1	Introduction and calibration terminology	771

6.1.2	Calibration methods	772
6.1.3	When to calibrate	774
6.2	Synchronization marks and axis movement directions	775
6.2.1	Synchronization marks and synchronization position for axes	775
6.2.2	Calibration movement directions for all axes	779
6.3	Updating revolution counters	780
6.3.1	Updating revolution counters on OmniCore robots	780
6.4	Calibrating with Axis Calibration method	797
6.4.1	Description of Axis Calibration	797
6.4.2	Calibration tools for Axis Calibration	800
6.4.3	Installation locations for the calibration tools	802
6.4.4	Axis Calibration - Running the calibration procedure	804
6.4.5	Reference calibration	808
6.5	Calibrating the robot	809
6.5.1	Calibration position	809
6.5.2	Calibrating axis 1 and axis 2	810
6.5.3	Calibrating axis 3 and axis 4	811
6.6	Verifying the calibration	819
6.7	Checking the synchronization position	820
7	Troubleshooting	821
7.1	Introduction to troubleshooting	821
7.2	Oil and grease stains on motors and gearboxes	823
7.3	Mechanical noise or dissonance	824
7.4	Manipulator collapses on power down	826
7.5	Motor temperature too high	827
8	Decommissioning	829
8.1	Introduction to decommissioning	829
8.2	Environmental information	830
8.3	Scrapping of robot	832
9	Reference information	833
9.1	Introduction	833
9.2	Applicable standards	834
9.3	Unit conversion	835
9.4	Screw joints	836
9.5	Weight specifications	839
9.6	Standard toolkit	840
9.7	Special tools	841
9.8	Lifting accessories and lifting instructions	842
10	Spare parts	843
10.1	Spare part lists and illustrations	843
	Index	845

This page is intentionally left blank

Overview of this manual

About this manual

This manual contains instructions for:

- mechanical and electrical installation of the IRB 910INV
- maintenance of the IRB 910INV
- mechanical and electrical repair of the IRB 910INV

The robot described in this manual has the following protection types:

- *Standard*
 - *Clean Room*
-

Usage

This manual should be used during:

- installation and commissioning, from lifting the product to its work site and securing it to the foundation, to making it ready for operation
- maintenance work
- repair work
- decommissioning work



Note

It is the responsibility of the integrator to conduct a risk assessment of the final application.

It is the responsibility of the integrator to provide safety and user guides for the robot system.

Who should read this manual?

This manual is intended for:

- installation personnel
 - maintenance personnel
 - repair personnel.
-

Prerequisites

A maintenance/repair/installation craftsman working with an ABB robot must:

- be trained by ABB and have the required knowledge of mechanical and electrical installation/repair/maintenance work.
 - be trained to respond to emergencies or abnormal situations.
-

Product manual scope

The manual covers all variants and designs of the IRB 910INV. Some variants and designs may have been removed from the business offer and are no longer available for purchase.

Continues on next page

References

Documentation referred to in the manual, is listed in the table below.

Document name	Document ID
<i>Product manual, spare parts - IRB 910INV</i>	<i>Document.ID-1</i>
<i>Product specification - IRB 910INV</i>	<i>3HAC068057-001</i>
<i>Circuit diagram - IRB 910INV</i>	<i>3HAC061899-011</i>
<i>Safety manual for robot - Manipulator and IRC5 or OmniCore controllerⁱ</i>	<i>3HAC031045-001</i>
<i>Product manual - OmniCore C30</i>	<i>3HAC060860-001</i>
<i>Product manual - OmniCore C90XT</i>	<i>3HAC073706-001</i>
<i>Product manual - OmniCore E10</i>	<i>3HAC079399-001</i>
<i>Operating manual - OmniCore</i>	<i>3HAC065036-001</i>
<i>Application manual - Controller software OmniCore</i>	<i>3HAC066554-001</i>
<i>Application manual - CalibWare Field</i>	<i>3HAC030421-001</i>
<i>Technical reference manual - Event logs for RobotWare 7</i>	<i>3HAC066553-001</i>
<i>Technical reference manual - Lubrication in gearboxes</i>	<i>3HAC042927-001</i>
<i>Technical reference manual - System parameters</i>	<i>3HAC065041-001</i>

ⁱ This manual contains all safety instructions from the product manuals for the manipulators and the controllers.

Revisions

Revision	Description
A	First edition.
B	Published in release 19D. The following updates are done in this revision: <ul style="list-style-type: none"> The protection type <i>Clean Room</i> and protection class IP54 are added throughout the manual. Updated the calibration position figure and added a note to remind the difference between calibration position and synchronization position. Added a note to the action after the fine calibration of axis 3 and axis 4.
C	Published in release 20A. The following updates are done in this revision: <ul style="list-style-type: none"> Added information of resonance sounds in troubleshooting for mechanical noise or dissonance. Clarified text about position of robot and added table with dependencies between axes during Axis Calibration. FlexPendant terminology updated for calibration procedures.
D	Published in release 20B. The following updates are made in this revision: <ul style="list-style-type: none"> Article number of Calibration tool box, Axis Calibration is changed from 3HAC062326-001 to 3HAC074119-001. Updated sleeve tighten torque. Updated ball screw grease information. Supported controller OmniCore C90XT is added.
E	Published in release 20D. The following updates are made in this revision: <ul style="list-style-type: none"> Updated maintenance activity interval for robot overhaul from 40000 hours to 20000 hours.

Continues on next page

Revision	Description
F	Published in release 21A. The following updates are made in this revision: <ul style="list-style-type: none"> Updated the cleaning method for protection class IP54. Connector types for CP/CS and Ethernet floor cable wiring are added.
G	Published in release 21B. The following updates are done in this revision: <ul style="list-style-type: none"> Text regarding fastener quality is updated, see Fastener quality on page 81. Text regarding diameter of air hoses is updated, see Customer connections on page 87. Added maintenance activities of running the <i>Brake Check</i> and <i>Cyclic Brake Check</i> routines. See Maintenance schedule on page 94. Removed maintenance activity of inspecting oil seepage and updated troubleshooting description about oil and grease stains on motors and gearboxes. Added a note to remind users that mechanical stop locations cannot be adjusted. See Adjusting the working range on page 82. Added grounding point information back. See Grounding and bonding point on manipulator on page 86.
H	Published in release 21C. The following updates are done in this revision: <ul style="list-style-type: none"> Updated robot power cable information, see Robot cables on page 84. Updated attachment screw information. Updated the naming of timing belt tension adjustment tools, from acoustic tensiometer and tensiometer to sonic tension meter and dynamometer, respectively.
J	Published in release 21D. The following updates are done in this revision: <ul style="list-style-type: none"> Updated signal lamp information, see Installation of signal lamp (option) on page 72. Supported controller OmniCore E10 is added.
K	Published in release 22A. The following updates are done in this revision: <ul style="list-style-type: none"> Added information about length of thread engagement for attachment screws. Added an alternative interval for lubricating the ball screw spline unit. Added troubleshooting for high motor temperature, see Motor temperature too high on page 827. Updated information about Gleitmo treated screws, see Screw joints on page 836. Corrected timing belt description, see Inspecting timing belts on page 111.
L	Published in release 22B. The following updates are done in this revision: <ul style="list-style-type: none"> Updated robot power cable information, see Robot cables on page 84. Added cleaning instructions for robots with protection type Clean Room.
M	Published in release 22C. The following updates are done in this revision: <ul style="list-style-type: none"> Updated information label figure. Updated motors spare part numbers.
N	Published in release 22D. The following updates are done in this revision: <ul style="list-style-type: none"> Updated information in Maintenance schedule on page 94.
P	Published in release 23B. The following updates are done in this revision: <ul style="list-style-type: none"> Updated image for calibration position axis 3 and axis 4.

Product documentation

Categories for user documentation from ABB Robotics

The user documentation from ABB Robotics is divided into a number of categories. This listing is based on the type of information in the documents, regardless of whether the products are standard or optional.



Tip

All documents can be found via myABB Business Portal, www.abb.com/myABB.

Product manuals

Manipulators, controllers, DressPack/SpotPack, and most other hardware is delivered with a **Product manual** that generally contains:

- Safety information.
- Installation and commissioning (descriptions of mechanical installation or electrical connections).
- Maintenance (descriptions of all required preventive maintenance procedures including intervals and expected life time of parts).
- Repair (descriptions of all recommended repair procedures including spare parts).
- Calibration.
- Troubleshooting.
- Decommissioning.
- Reference information (safety standards, unit conversions, screw joints, lists of tools).
- Spare parts list with corresponding figures (or references to separate spare parts lists).
- References to circuit diagrams.

Technical reference manuals

The technical reference manuals describe reference information for robotics products, for example lubrication, the RAPID language, and system parameters.

Application manuals

Specific applications (for example software or hardware options) are described in **Application manuals**. An application manual can describe one or several applications.

An application manual generally contains information about:

- The purpose of the application (what it does and when it is useful).
- What is included (for example cables, I/O boards, RAPID instructions, system parameters, software).
- How to install included or required hardware.
- How to use the application.

Continues on next page

- Examples of how to use the application.

Operating manuals

The operating manuals describe hands-on handling of the products. The manuals are aimed at those having first-hand operational contact with the product, that is production cell operators, programmers, and troubleshooters.

How to read the product manual

Reading the procedures

The procedures contain all information required for the installation or service activity and can be printed out separately when needed for a certain service procedure.

Safety information

The manual includes a separate safety chapter that must be read through before proceeding with any service or installation procedures. All procedures also include specific safety information when dangerous steps are to be performed.

Read more in the chapter [Safety on page 15](#).

Illustrations

The product is illustrated with general figures that does not take painting or protection type in consideration.

Likewise, certain work methods or general information that is valid for several product models, can be illustrated with illustrations that show a different product model than the one that is described in the current manual.

1 Safety

1.1 Safety information

1.1.1 Limitation of liability

Limitation of liability

Any information given in this manual regarding safety must not be construed as a warranty by ABB that the industrial robot will not cause injury or damage even if all safety instructions are complied with.

The information does not cover how to design, install and operate a robot system, nor does it cover all peripheral equipment that can influence the safety of the robot system.

In particular, liability cannot be accepted if injury or damage has been caused for any of the following reasons:

- Use of the robot in other ways than intended.
- Incorrect operation or maintenance.
- Operation of the robot when the safety devices are defective, not in their intended location or in any other way not working.
- When instructions for operation and maintenance are not followed as intended.
- Non-authorized design modifications of the robot.
- Repairs on the robot and its spare parts carried out by in-experienced or non-qualified personnel.
- Foreign objects.
- Force majeure.

Spare parts and equipment

ABB supplies original spare parts and equipment which have been tested and approved for their intended use. The installation and/or use of non-original spare parts and equipment can negatively affect the safety, function, performance, and structural properties of the robot. ABB is not liable for damages caused by the use of non-original spare parts and equipment.

1 Safety

1.1.2 Requirements on personnel

1.1.2 Requirements on personnel

General

Only personnel with appropriate training are allowed to install, maintain, service, repair, and use the robot. This includes electrical, mechanical, hydraulics, pneumatics, and other hazards identified in the risk assessment.

Persons who are under the influence of alcohol, drugs or any other intoxicating substances are not allowed to install, maintain, service, repair, or use the robot.

The plant liable must make sure that the personnel is trained on the robot, and on responding to emergency or abnormal situations.

Personal protective equipment

Use personal protective equipment, as stated in the instructions.

1.2 Safety signals and symbols

1.2.1 Safety signals in the manual







Introduction to safety signals

This section specifies all safety signals used in the user manuals. Each signal consists of:

- A caption specifying the hazard level (DANGER, WARNING, or CAUTION) and the type of hazard.
- Instruction about how to reduce the hazard to an acceptable level.
- A brief description of remaining hazards, if not adequately reduced.

Hazard levels

The table below defines the captions specifying the hazard levels used throughout this manual.

Symbol	Designation	Significance
	DANGER	Signal word used to indicate an imminently hazardous situation which, if not avoided, will result in serious injury.
	WARNING	Signal word used to indicate a potentially hazardous situation which, if not avoided, could result in serious injury.
	ELECTRICAL SHOCK	Signal word used to indicate a potentially hazardous situation related to electrical hazards which, if not avoided, could result in serious injury.
	CAUTION	Signal word used to indicate a potentially hazardous situation which, if not avoided, could result in slight injury.
	ELECTROSTATIC DISCHARGE (ESD)	Signal word used to indicate a potentially hazardous situation which, if not avoided, could result in severe damage to the product.
	NOTE	Signal word used to indicate important facts and conditions.

Continues on next page

1 Safety

1.2.1 Safety signals in the manual

Continued

Symbol	Designation	Significance
	TIP	Signal word used to indicate where to find additional information or how to do an operation in an easier way.

1.2.2 Safety symbols on manipulator labels

Introduction to symbols

This section describes safety symbols used on labels (stickers) on the manipulator. Symbols are used in combinations on the labels, describing each specific warning. The descriptions in this section are generic, the labels can contain additional information such as values.



Note

The symbols on the labels on the product must be observed. Additional symbols added by the integrator must also be observed.



Types of symbols

Both the manipulator and the controller are marked with symbols, containing important information about the product. This is important for all personnel handling the robot, for example during installation, service, or operation.

The safety labels are language independent, they only use graphics. See [Symbols on safety labels on page 19](#).

The information labels can contain information in text.

Symbols on safety labels



Symbol	Description
 xx0900000812	Warning! Warns that an accident <i>may</i> occur if the instructions are not followed that can lead to serious injury, possibly fatal, and/or great damage to the product. It applies to warnings that apply to danger with, for example, contact with high voltage electrical units, explosion or fire risk, risk of poisonous gases, risk of crushing, impact, fall from height, etc.
 xx0900000811	Caution! Warns that an accident may occur if the instructions are not followed that can result in injury and/or damage to the product. It also applies to warnings of risks that include burns, eye injury, skin injury, hearing damage, crushing or slipping, tripping, impact, fall from height, etc. Furthermore, it applies to warnings that include function requirements when fitting and removing equipment where there is a risk of damaging the product or causing a breakdown.
 xx0900000839	Prohibition Used in combinations with other symbols.

Continues on next page



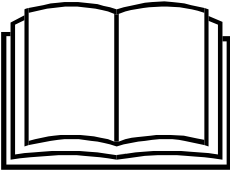
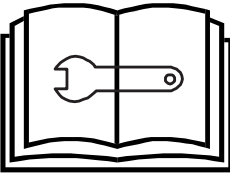
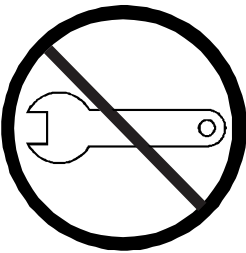
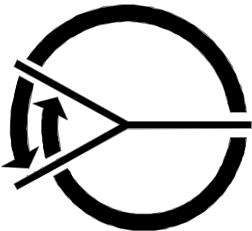

1 Safety

1.2.2 Safety symbols on manipulator labels

Continued

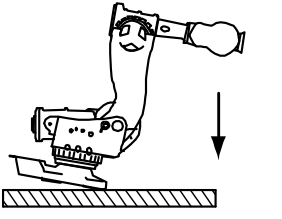
Symbol	Description
 xx0900000813	See user documentation Read user documentation for details. Which manual to read is defined by the symbol: <ul style="list-style-type: none">• No text: <i>Product manual</i>.
 xx0900000816	Before disassembly, see product manual
 xx0900000815	Do not disassemble Disassembling this part can cause injury.
 xx0900000814	Extended rotation This axis has extended rotation (working area) compared to standard.
 xx0900000808	Brake release Pressing this button will release the brakes. This means that the robot arm can fall down.

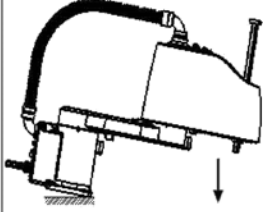

Continues on next page

Symbol	Description
 <p>xx0900000810</p>   <p>3HAC 057068-001</p> <p>xx1500002402</p>	<p>Tip risk when loosening bolts The robot can tip over if the bolts are not securely fastened.</p>
 <p>xx0900000817</p>	<p>Crush Risk of crush injuries.</p>





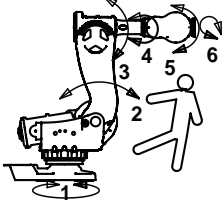
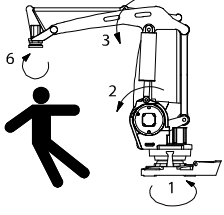
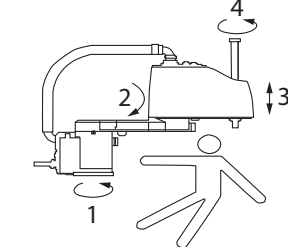
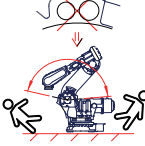

1 Safety

1.2.2 Safety symbols on manipulator labels

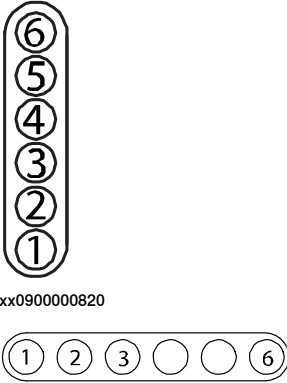
Continued

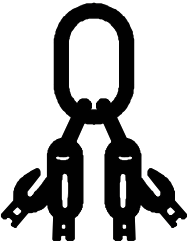
Symbol	Description
 <p>xx0900000818</p>  <p>xx1300001087</p>	<p>Heat Risk of heat that can cause burns. (Both signs are used)</p>
 <p>xx0900000819</p>  <p>xx1000001141</p>  <p>xx1500002616</p>	<p>Moving robot The robot can move unexpectedly.</p>
 <p>xx1700000813</p>	<p>Moving robot The robot can move unexpectedly when floor standing. Always use transportation lock screw in floor standing position.</p>

Continues on next page





Symbol	Description
 <p>xx0900000820</p> <p>xx1000001140</p>	<p>Brake release buttons</p>
 <p>xx0900000821</p>	<p>Lifting bolt</p>
 <p>xx1000001242</p>	<p>Adjustable chain sling with shortener</p>
 <p>xx0900000822</p>	<p>Lifting of robot</p>
 <p>xx0900000823</p>	<p>Oil Can be used in combination with prohibition if oil is not allowed.</p>
 <p>xx0900000824</p>	<p>Mechanical stop</p>

Continues on next page

1 Safety

1.2.2 Safety symbols on manipulator labels

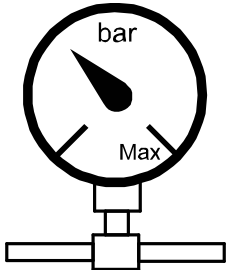
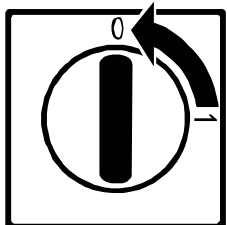
Continued

Symbol	Description
 xx1000001144	No mechanical stop
 xx0900000825	Stored energy Warns that this part contains stored energy. Used in combination with <i>Do not disassemble</i> symbol.
 xx0900000826	Pressure Warns that this part is pressurized. Usually contains additional text with the pressure level.
 xx0900000827	Shut off with handle Use the power switch on the controller.
 xx1400002648	Do not step Warns that stepping on these parts can cause damage to the parts.

1.3 Robot stopping functions

Protective stop and emergency stop

The protective stops and emergency stops are described in the product manual for the controller.

For more information see:

- *Product manual - OmniCore C30*
- *Product manual - OmniCore C90XT*
- *Product manual - OmniCore E10*

1 Safety

1.4 Safety during installation and commissioning

1.4 Safety during installation and commissioning

National or regional regulations

The integrator of the robot system is responsible for the safety of the robot system.

The integrator is responsible that the robot system is designed and installed in accordance with the safety requirements set forth in the applicable national and regional standards and regulations.

The integrator of the robot system is required to perform a risk assessment.

Layout

The robot integrated to a robot system shall be designed to allow safe access to all spaces during installation, operation, maintenance, and repair.

If robot movement can be initiated from an external control panel then an emergency stop must also be available.

If the manipulator is delivered with mechanical stops, these can be used for reducing the working space.

A perimeter safeguarding, for example a fence, shall be dimensioned to withstand the following:

- The force of the manipulator.
- The force of the load handled by the robot if dropped or released at maximum speed.
- The maximum possible impact caused by a breaking or malfunctioning rotating tool or other device fitted to the robot.

The maximum TCP speed and the maximum velocity of the robot axes are detailed in the section *Robot motion* in the product specification for the respective manipulator.

Consider exposure to hazards, such as slipping, tripping, and falling.

Hazards due to the working position and posture for a person working with or near the robot shall be considered.

Hazards due to noise emission from the robot needs to be considered.

Consider hazards from other equipment in the robot system, for example, that guards remain active until identified hazards are reduced to an acceptable level.

Allergenic material

See [Environmental information on page 830](#) for specification of allergenic materials in the product, if any.

Securing the robot to the foundation

The robot must be properly fixed to its foundation/support, as described in the respective product manual.

When the robot is installed at a height, hanging, or other than mounted directly on the floor, there will be additional hazards.

Continues on next page

Electrical safety

Incoming mains must be installed to fulfill national regulations.

The power supply wiring to the robot must be sufficiently fused and if necessary, it must be possible to disconnect it manually from the mains power.

The power to the robot must be turned off with the main switch and the mains power disconnected when performing work inside the controller cabinet. Lock and tag shall be considered.

Harnesses between controller and manipulator shall be fixed and protected to avoid tripping and wear.

Wherever possible, power on/off or rebooting the robot controller shall be performed with all persons outside the safeguarded space.



Note

Use a CARBON DIOXIDE (CO₂) extinguisher in the event of a fire in the robot.

Safety devices

The integrator is responsible for that the safety devices necessary to protect people working with the robot system are designed and installed correctly.

When integrating the robot with external devices to a robot system:

- The integrator of the robot system must ensure that emergency stop functions are interlocked in accordance with applicable standards.
- The integrator of the robot system must ensure that safety functions are interlocked in accordance with applicable standards.

Other hazards

A robot may perform unexpected limited movement.



WARNING

Manipulator movements can cause serious injuries on users and may damage equipment.

The risk assessment should also consider other hazards arising from the application, such as, but not limited to:

- Water
- Compressed air
- Hydraulics

End-effector hazards require particular attention for applications which involve close human collaboration with the robot.

Continues on next page

1 Safety

1.4 Safety during installation and commissioning

Continued

Pneumatic or hydraulic related hazards



Note

The pressure in the complete pneumatic or hydraulic systems must be released before service and maintenance.

All components in the robot system that remain pressurized after switching off the power to the robot must be marked with clearly visible drain facilities and a warning sign that indicates the hazard of stored energy.

Loss of pressure in the robot system may cause parts or objects to drop.

Dump valves should be used in case of emergency.

Shot bolts should be used to prevent tools, etc., from falling due to gravity.

All pipes, hoses, and connections have to be inspected regularly for leaks and damage. Damage must be repaired immediately.

Verify the safety functions

Before the robot system is put into operation, verify that the safety functions are working as intended and that any remaining hazards identified in the risk assessment are mitigated to an acceptable level.

1.5 Safety during operation

Automatic operation

Verify the application in the operating mode manual reduced speed, before changing mode to automatic and initiating automatic operation.

Unexpected movement of robot arm



WARNING

Hazards due to the use of brake release devices and/or gravity beneath the manipulator shall be considered.

A robot may perform unexpected limited movement.



WARNING

Manipulator movements can cause serious injuries on users and may damage equipment.

1 Safety

1.6.1 Safety during maintenance and repair

1.6 Safety during maintenance and repair

1.6.1 Safety during maintenance and repair

General

Corrective maintenance must only be carried out by personnel trained on the robot. Maintenance or repair must be done with all electrical, pneumatic, and hydraulic power switched off, that is, no remaining hazards.

Hazards due to stored mechanical energy in the manipulator for the purpose of counterbalancing axes must be considered before maintenance or repair.

Never use the robot as a ladder, which means, do not climb on the controller, manipulator, including motors, or other parts. There are hazards of slipping and falling. The robot might be damaged.

Make sure that there are no loose screws, turnings, or other unexpected parts remaining after work on the robot has been performed.

When the work is completed, verify that the safety functions are working as intended.

Hot surfaces

Surfaces can be hot after running the robot, and touching these may result in burns. Allow the surfaces to cool down before maintenance or repair.

Allergic reaction

Warning	Description	Elimination/Action
 Allergic reaction	When working with lubricants there is a risk of an allergic reaction.	Make sure that protective gear like goggles and gloves are always worn.

Gearbox lubricants (oil or grease)

When handling oil, grease, or other chemical substances the safety information of the respective manufacturer must be observed.







Note

Take special care when handling hot lubricants.

Warning	Description	Elimination/Action
 Hot oil or grease	Changing and draining gearbox oil or grease may require handling hot lubricant heated up to 90 °C.	Make sure that protective gear like goggles and gloves are always worn during this activity.

Continues on next page

Warning	Description	Elimination/Action
 Allergic reaction	When working with lubricants there is a risk of an allergic reaction.	Make sure that protective gear like goggles and gloves are always worn.
 Possible pressure build-up in gearbox	When opening the oil or grease plug, there may be pressure present in the gearbox, causing lubricant to spray from the opening.	Open the plug carefully and keep away from the opening. Do not overfill the gearbox when filling.
 Do not overfill	Overfilling of gearbox lubricant can lead to internal over-pressure inside the gearbox which in turn may: <ul style="list-style-type: none"> • damage seals and gaskets • completely press out seals and gaskets • prevent the robot from moving freely. 	Make sure not to overfill the gearbox when filling it with oil or grease. After filling, verify that the level is correct.
 Specified amount depends on drained volume	The specified amount of oil or grease is based on the total volume of the gearbox. When changing the lubricant, the amount refilled may differ from the specified amount, depending on how much has previously been drained from the gearbox.	After filling, verify that the level is correct.

Hazards related to batteries

Under rated conditions, the electrode materials and liquid electrolyte in the batteries are sealed and not exposed to the outside.

There is a hazard in case of abuse (mechanical, thermal, electrical) which leads to the activation of safety valves and/or the rupture of the battery container. As a result under certain circumstances, electrolyte leakage, electrode materials reaction with moisture/water or battery vent/explosion/fire may follow.

Do not short circuit, recharge, puncture, incinerate, crush, immerse, force discharge or expose to temperatures above the declared operating temperature range of the product. Risk of fire or explosion.

Operating temperatures are listed in [Operating conditions, robot on page 39](#).

See safety instructions for the batteries in *Material/product safety data sheet - Battery pack (3HAC043118-001)*.

Unexpected movement of robot arm



WARNING

Hazards due to the use of brake release devices and/or gravity beneath the manipulator shall be considered.

Continues on next page

1 Safety

1.6.1 Safety during maintenance and repair

Continued

A robot may perform unexpected limited movement.



WARNING

Manipulator movements can cause serious injuries on users and may damage equipment.

Related information

See also the safety information related to installation and operation.

1.6.2 Emergency release of the robot axes

Description

In an emergency situation, the brakes on a robot axis can be released manually by pushing a brake release button.

How to release the brakes is described in the section:

- [Manually releasing the brakes on page 65](#).

The robot may be moved manually on smaller robot models, but larger models may require using an overhead crane or similar equipment.

Increased injury

Before releasing the brakes, make sure that the weight of the manipulator does not result in additional hazards, for example, even more severe injuries on a trapped person.



DANGER

When releasing the holding brakes, the robot axes may move very quickly and sometimes in unexpected ways.

Make sure no personnel is near or beneath the robot.

1 Safety

1.6.3 Brake testing

1.6.3 Brake testing

When to test

During operation, the holding brake of each axis normally wears down. A test can be performed to determine whether the brake can still perform its function.



Note

Note that the following axes do not have a brake:

- Axis 1
- Axis 2
- Axis 4 (for IRB 910INV-3/0.35)

How to test

The function of the holding brake of each axis motor may be verified as described below:

- 1 Run each axis to a position where the combined weight of the manipulator and any load is maximized (maximum static load).
- 2 Switch the motor to the MOTORS OFF.
- 3 Inspect and verify that the axis maintains its position.

If the manipulator does not change position as the motors are switched off, then the brake function is adequate.



Note

It is recommended to run the service routine *BrakeCheck* as part of the regular maintenance, see the operating manual for the robot controller.

For robots with the option SafeMove, the *Cyclic Brake Check* routine is recommended. See the manual for SafeMove in [References on page 10](#).

1.7 Safety during troubleshooting

General

When troubleshooting requires work with power switched on, special considerations must be taken:

- Safety circuits might be muted or disconnected.
- Electrical parts must be considered as *live*.
- The manipulator can move unexpectedly at any time.



DANGER

Troubleshooting on the controller while powered on must be performed by personnel trained by ABB or by ABB field engineers.

A risk assessment must be done to address both robot and robot system specific hazards.



WARNING

Hazards due to the use of brake release devices and/or gravity beneath the manipulator shall be considered.

A robot may perform unexpected limited movement.



WARNING

Manipulator movements can cause serious injuries on users and may damage equipment.

Related information

See also the safety information related to installation, operation, maintenance, and repair.

1 Safety

1.8 Safety during decommissioning

1.8 Safety during decommissioning

General

See section [Decommissioning on page 829](#).

If the robot is decommissioned for storage, take extra precaution to reset safety devices to delivery status.

Unexpected movement of robot arm



WARNING

Hazards due to the use of brake release devices and/or gravity beneath the manipulator shall be considered.

A robot may perform unexpected limited movement.



WARNING

Manipulator movements can cause serious injuries on users and may damage equipment.

2 Manipulator description

2.1 Technical data

Weight, robot

The table shows the weight of the robot.

Robot model	Nominal weight
IRB 910INV	IRB 910INV-3/0.35: 19 kg
	IRB 910INV-6/0.55: 22 kg



Note

The weight does not include additional options, tools and other equipment fitted on the robot.

Mounting positions

The table shows valid mounting positions and the installation (mounting) angle for the manipulator.

Mounting position	Installation angle
Inverted	0° ⁱ

ⁱ A tilt of up to 3° does not affect the payload or reach, but it can have a negative impact on performance and lifetime. The actual value must be set in the system parameters.



Note

The actual mounting angle must always be configured in the system parameters, otherwise the performance and lifetime is affected. For details, see *Technical reference manual - System parameters*.

Loads on foundation, robot

The illustration shows the directions of the robots stress forces.

Continues on next page

2 Manipulator description

2.1 Technical data

Continued

The directions are valid for all inverted robots.

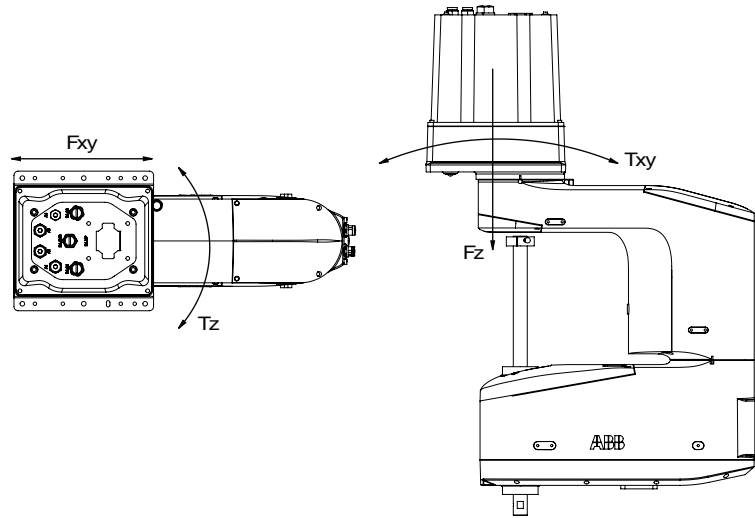

xx190000059

F_{xy}	Force in any direction in the XY plane
F_z	Force in the Z plane
T_{xy}	Bending torque in any direction in the XY plane
T_z	Bending torque in the Z plane

The table shows the various forces and torques working on the robot during different kinds of operation.



Note

These forces and torques are extreme values that are rarely encountered during operation. The values also never reach their maximum at the same time!



WARNING

The robot installation is restricted to the mounting options given in following load table(s).

Inverted

Force	Endurance load (in operation)	Max. load (emergency stop)
Force xy	$\pm 420/440$ N	$\pm 770/710$ N
Force z	$190 \pm 135/220 \pm 200$ N	$190 \pm 660/220 \pm 110$ N
Torque xy	$\pm 220/170$ Nm	$\pm 220/320$ Nm
Torque z	$\pm 90/125$ Nm	$\pm 160/190$ Nm

Continues on next page

Requirements, foundation

The table shows the requirements for the foundation where the weight of the installed robot is included:

Requirement	Value	Note
Flatness of foundation surface	0.1/500 mm	Flat foundations give better repeatability of the resolver calibration compared to original settings on delivery from ABB. The value for levelness aims at the circumstance of the anchoring points in the robot base. In order to compensate for an uneven surface, the robot can be recalibrated during installation. If resolver/encoder calibration is changed this will influence the absolute accuracy.
Minimum resonance frequency	22 Hz  Note It may affect the manipulator lifetime to have a lower resonance frequency than recommended.	The value is recommended for optimal performance. Due to foundation stiffness, consider robot mass including equipment. ⁱ For information about compensating for foundation flexibility, see the description of <i>Motion Process Mode</i> in the manual that describes the controller software option, see References on page 10 .
Minimum foundation material yield strength	150 MPa	

ⁱ The minimum resonance frequency given should be interpreted as the frequency of the robot mass/inertia, robot assumed stiff, when a foundation translational/torsional elasticity is added, i.e., the stiffness of the pedestal where the robot is mounted. The minimum resonance frequency should not be interpreted as the resonance frequency of the building, floor etc. For example, if the equivalent mass of the floor is very high, it will not affect robot movement, even if the frequency is well below the stated frequency. The robot should be mounted as rigid as possible to the floor.
Disturbances from other machinery will affect the robot and the tool accuracy. The robot has resonance frequencies in the region 10 – 20 Hz and disturbances in this region will be amplified, although somewhat damped by the servo control. This might be a problem, depending on the requirements from the applications. If this is a problem, the robot needs to be isolated from the environment.

Storage conditions, robot

The table shows the allowed storage conditions for the robot:

Parameter	Value
Minimum ambient temperature	-25 °C
Maximum ambient temperature	55 °C
Maximum ambient temperature (less than 24 hrs)	70 °C
Maximum ambient humidity	95% at constant temperature (gaseous only)

Operating conditions, robot

The table shows the allowed operating conditions for the robot:

Parameter	Value
Minimum ambient temperature	5 °C ⁱ
Maximum ambient temperature	45 °C

Continues on next page

2 Manipulator description

2.1 Technical data

Continued

Parameter	Value
Maximum ambient humidity	95% at constant temperature

ⁱ At low environmental temperature < 10°C is, as with any other machine, a warm-up phase recommended to be run with the robot. Otherwise there is a risk that the robot stops or run with lower performance due to temperature dependent oil and grease viscosity.

Protection classes, robot

The table shows the available protection types of the robot, with the corresponding protection class.

Protection type	Protection class ⁱ
Manipulator, protection type Standard	IP30 ⁱⁱ IP54 (option 3350-540)
Manipulator, protection type Clean Room	ISO Class 1

ⁱ According to IEC 60529.

ⁱⁱ The protection class of the ballscrew area is IP20. For more information, please contact ABB.

Environmental information

The product complies with IEC 63000. *Technical documentation for the assessment of electrical and electronic products with respect to the restriction of hazardous substances.*

2.2 Robot dimensions

Dimensions of IRB 910INV-3/0.35

Robots with protection class IP30 (option 3350-300)

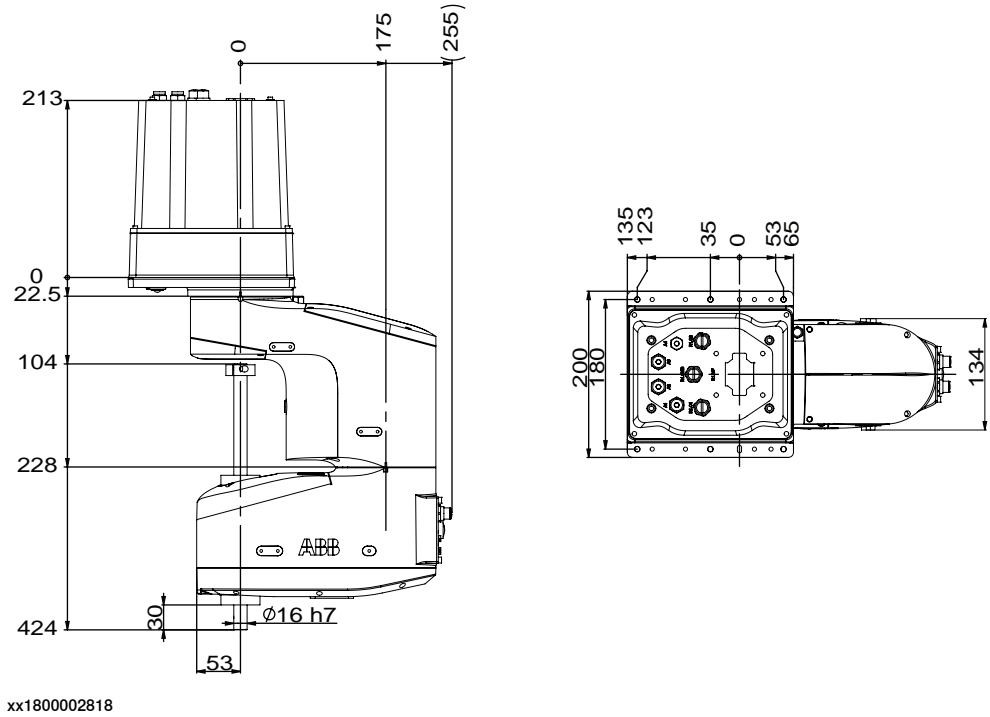

Robots with protection class IP54 (option 3350-540) or with protection type Clean Room (option 3351-1)

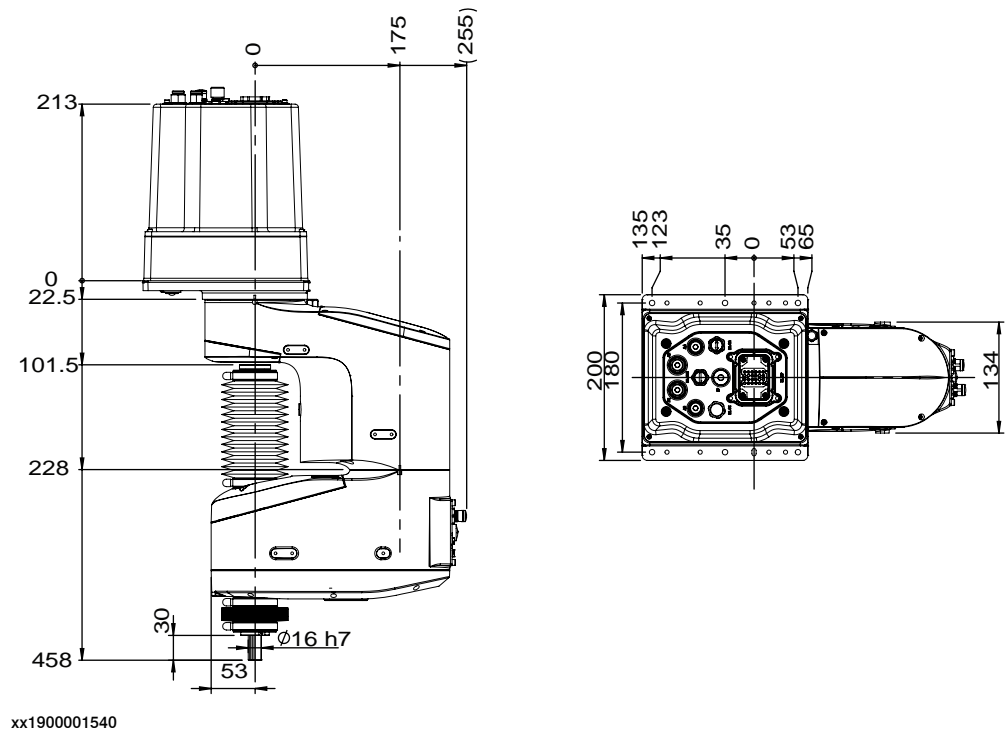

Continues on next page

2 Manipulator description

2.2 Robot dimensions

Continued

Dimensions of IRB 910INV-6/0.55

Robots with protection class IP30 (option 3350-300)

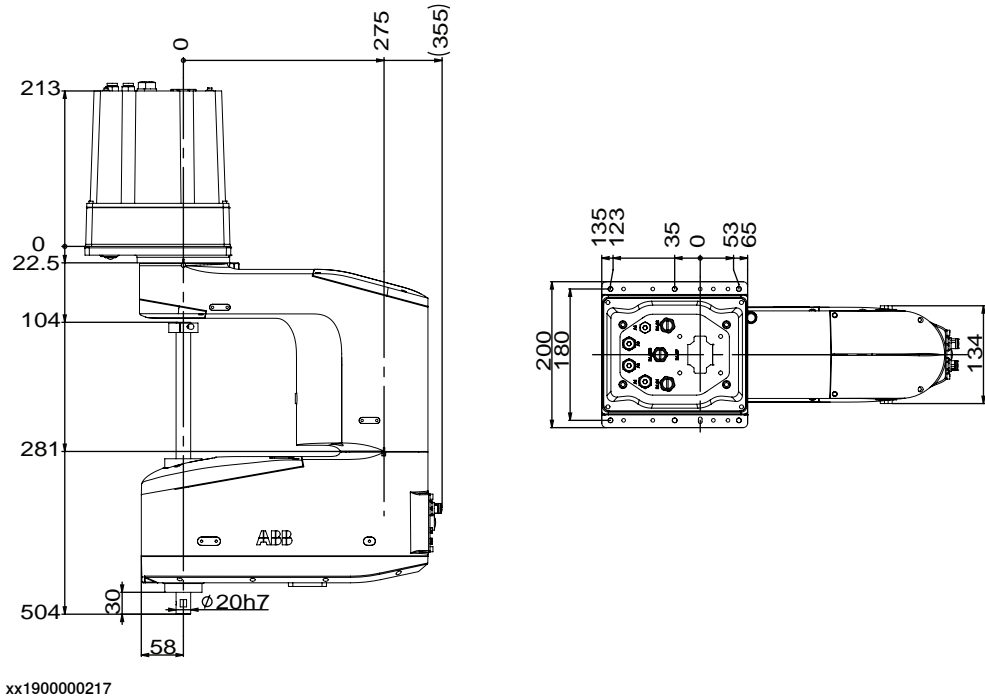

Robots with protection class IP54 (option 3350-540) or with protection type Clean Room (option 3351-1)

The figure shows the dimension of the IRB 910INV-6/0.55 for Clean Room/IP54.

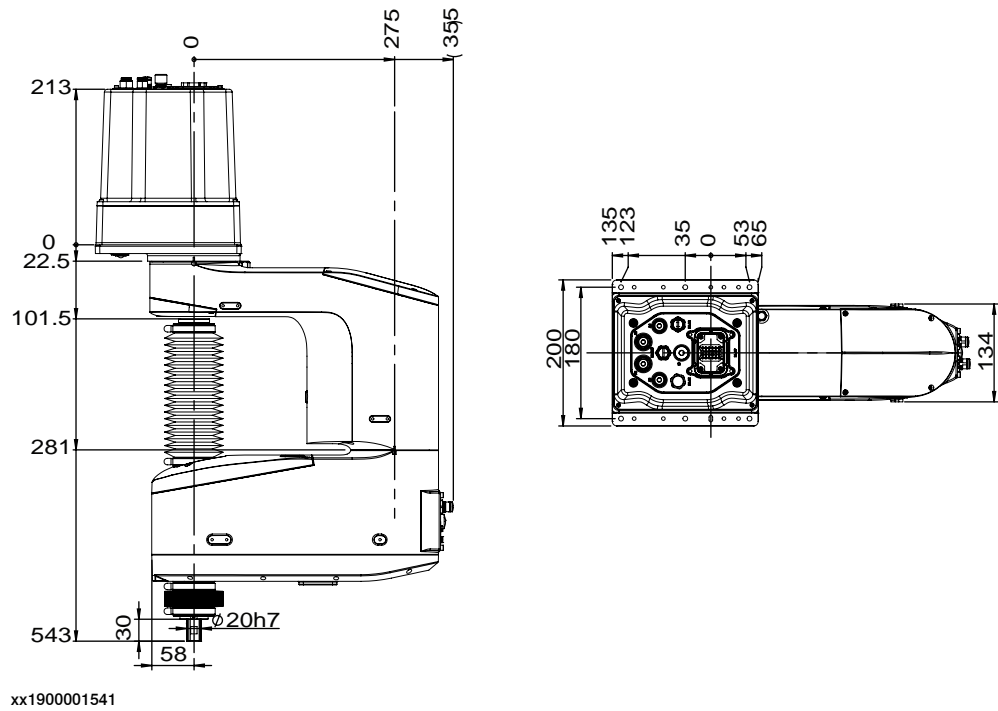

2.3 Working range

Illustration, working range and turning radius

This illustration shows the unrestricted working range and turning radius.

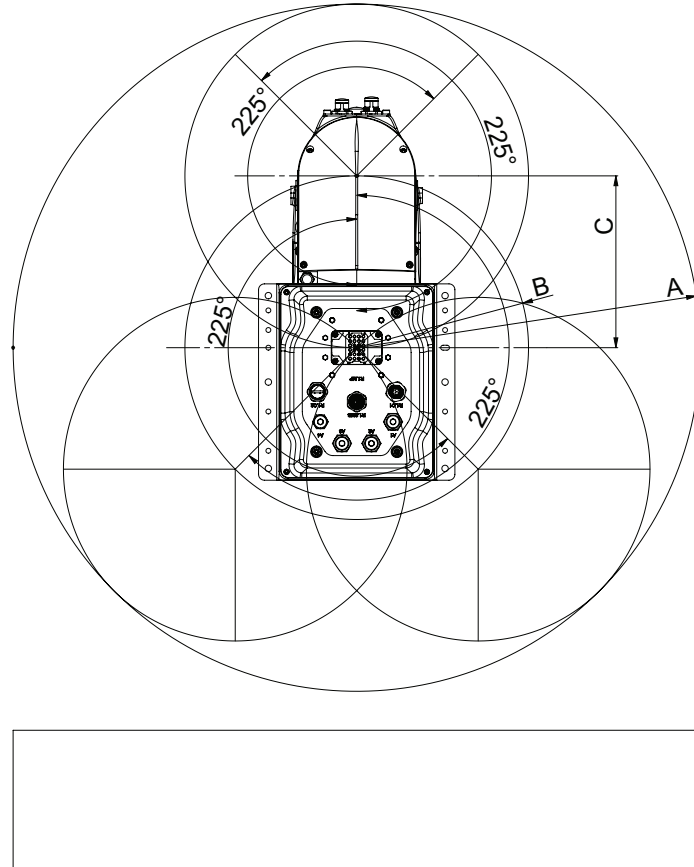

xx1800002809

	IRB 910INV-3/0.35		IRB 910INV-6/0.55	
	IP30	Clean Room/IP54	IP30	Clean Room/IP54
A	R350	R350	R550	R550
B	R175	R175	R275	R275
C	175	175	275	275
D	140	100	190	150

2 Manipulator description

2.4 Information labels

2.4 Information labels

Illustration

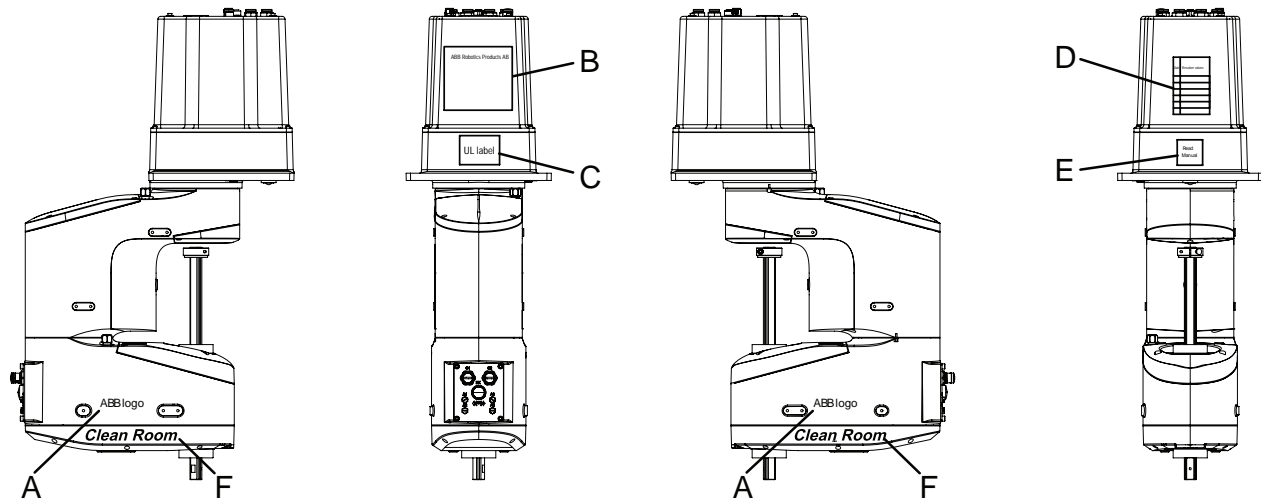

xx1900000072

A	ABB logo
B	WEEE label
C	Rating label
D	UL label
E	Calibration label
F	Read manual and caution
G	Clean Room label ⁱ

ⁱ Only for robots with protection type Clean Room.

2.5 The unit is sensitive to ESD

Description

ESD (electrostatic discharge) is the transfer of electrical static charge between two bodies at different potentials, either through direct contact or through an induced electrical field. When handling parts or their containers, personnel not grounded may potentially transfer high static charges. This discharge may destroy sensitive electronics.

Safe handling

Use one of the following alternatives:

- Use a wrist strap.

Wrist straps must be tested frequently to ensure that they are not damaged and are operating correctly.

- Use an ESD protective floor mat.

The mat must be grounded through a current-limiting resistor.

- Use a dissipative table mat.

The mat should provide a controlled discharge of static voltages and must be grounded.

This page is intentionally left blank

3 Installation and commissioning

3.1 Introduction to installation and commissioning

General

This chapter contains assembly instructions and information for installing the IRB 910INV at the working site.

See also the product manual for the robot controller.

The installation must be done by qualified installation personnel in accordance with the safety requirements set forth in the applicable national and regional standards and regulations.

The technical data is detailed in section [Technical data on page 37](#).

Safety information

Before any installation work is commenced, all safety information must be observed. There are general safety aspects that must be read through, as well as more specific safety information that describes the danger and safety risks when performing the procedures. Read the chapter [Safety on page 15](#) before performing any installation work.



Note

Always connect the IRB 910INV and the robot to protective earth and residual current device (RCD) before connecting to power and starting any installation work.

For more information see:

- *Product manual - OmniCore C30*
- *Product manual - OmniCore C90XT*
- *Product manual - OmniCore E10*

3 Installation and commissioning

3.2.1 Pre-installation procedure

3.2 Unpacking

3.2.1 Pre-installation procedure

Introduction

This section is intended for use when unpacking and installing the robot for the first time. It also contains information useful during later re-installation of the robot.

Prerequisites for installation personnel

Installation personnel working with an ABB product must:

- Be trained by ABB and have the required knowledge of mechanical and electrical installation/maintenance/repair work.
- Conform to all national and local codes.

Checking the pre-requisites for installation

	Action
1	Make a visual inspection of the packaging and make sure that nothing is damaged.
2	Remove the packaging.
3	Check for any visible transport damage.  Note Stop unpacking and contact ABB if transport damages are found.
4	Clean the unit with a lint-free cloth, if necessary.
5	Make sure that the lifting accessory used (if required) is suitable to handle the weight of the robot as specified in: Weight, robot on page 37
6	If the robot is not installed directly, it must be stored as described in: Storage conditions, robot on page 39
7	Make sure that the expected operating environment of the robot conforms to the specifications as described in: Operating conditions, robot on page 39
8	Before taking the robot to its installation site, make sure that the site conforms to: <ul style="list-style-type: none">• Loads on foundation, robot on page 37• Protection classes, robot on page 40• Requirements, foundation on page 39
9	Before moving the robot, please observe the stability of the robot: Risk of tipping/stability on page 49
10	When these prerequisites are met, the robot can be taken to its installation site as described in section: On-site installation on page 56
11	Install required equipment, if any.

3.2.2 Risk of tipping/stability

Risk of tipping

If the robot is not fastened to the foundation while moving the arm, the robot is not stable in the whole working area. Moving the arm will displace the center of gravity, which may cause the robot to tip over.

The transportation position is the most stable position.

Continues on next page

3 Installation and commissioning

3.2.2 Risk of tipping/stability

Continued

Do not change the robot position before securing it to the foundation!

Transportation position

This figure shows the robot in its transportation position.



CAUTION

Make sure that the robot is secured with the bracket in its shipping and transportation position.

If the robot is laid down, the grease may come out from the gearbox.

Continues on next page

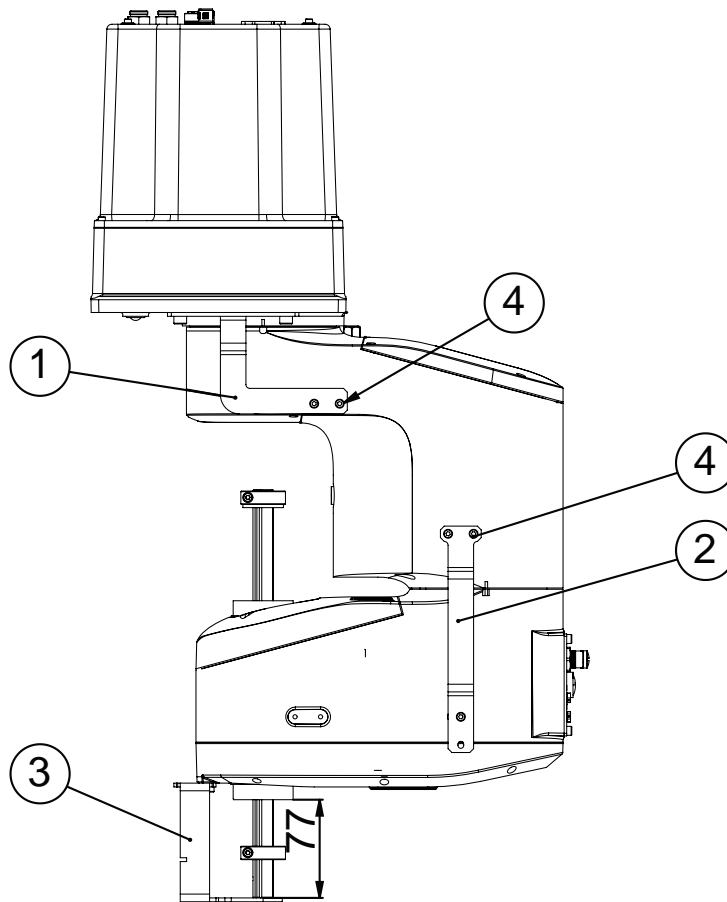
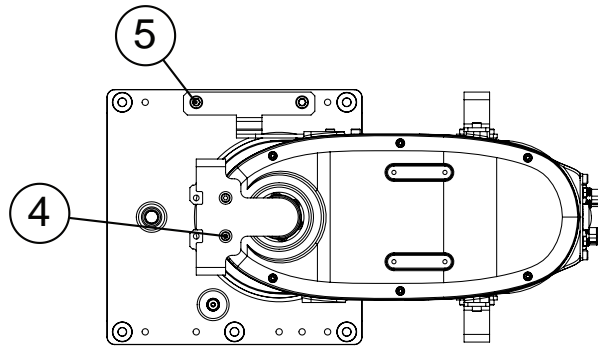

xx1800002812

1	Base inner arm fixture
2	Inner arm outer arm fixture
3	Ballscrew fixture
4	Hex socket head cap screw
5	Hex socket head cap screw

Continues on next page

3 Installation and commissioning

3.2.2 Risk of tipping/stability

Continued



Note

The robot might be positioned in a different position at delivery, due to actual configurations and options (for example DressPack).

Transportation bracket

At delivery, the robot is locked in the correct position with the transportation brackets for securing the position during shipping and transport. The bracket cannot be removed until the robot is secured to the foundation.

How to use the transportation bracket is described further in [Transportation bracket on page 53](#).



WARNING

The robot is likely to be mechanically unstable if not secured to the foundation.

3.2.3 Transportation bracket

Location of the transportation bracket

At delivery, the robot is locked in the correct position with the transportation brackets for securing the position during shipping and transport. The transportation brackets cannot be removed until the robot is secured to the foundation.



Note

Keep the brackets every time when it's removed from the robot for further use.

Continues on next page

3 Installation and commissioning

3.2.3 Transportation bracket

Continued

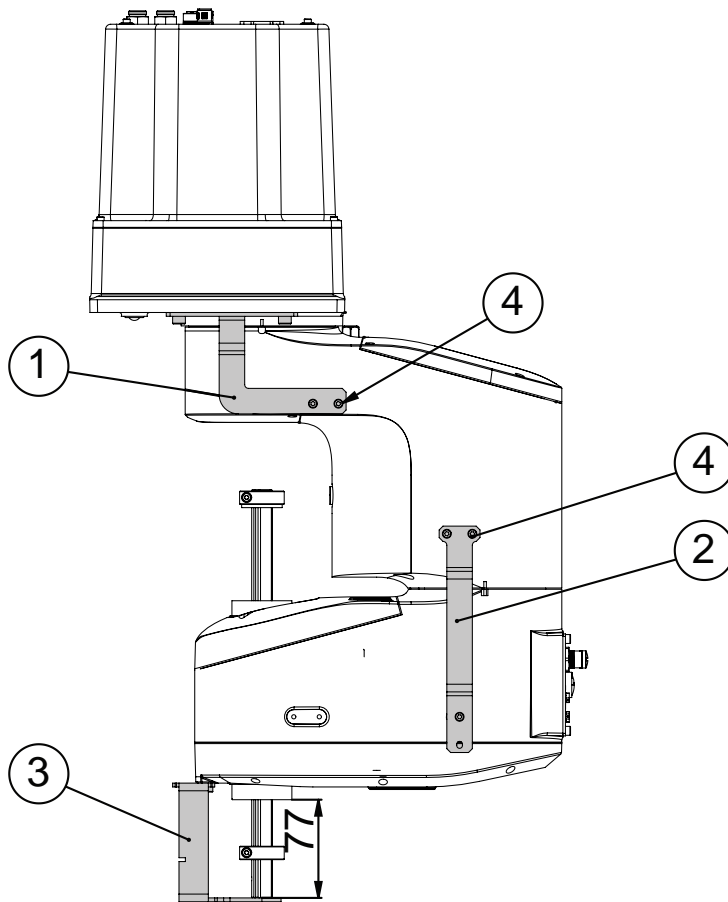
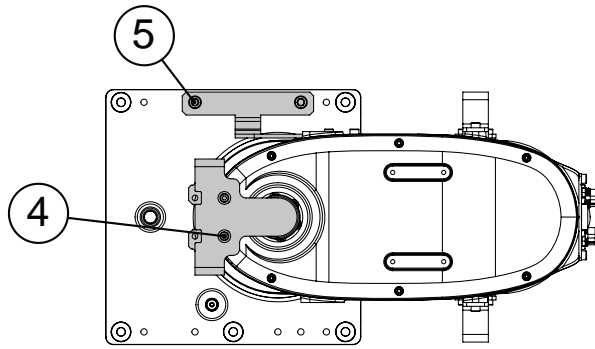

xx1800002813

1	Base inner arm fixture
2	Inner arm outer arm fixture
3	Ballscrew fixture
4	Hex socket head cap screw
5	Hex socket head cap screw

Continues on next page

Removing the transportation bracket

	Action	Note
1	 CAUTION For robots with protection type Clean Room Always cut the paint with a knife and grind the paint edge when disassembling parts of the robot! See <i>Cut the paint or surface on the robot before replacing parts on page 118.</i>	
2	Remove the screws.	
3	Remove the bracket.	

3 Installation and commissioning

3.3.1 Test run after installation, maintenance, or repair

3.3 On-site installation

3.3.1 Test run after installation, maintenance, or repair

Safe handling

Use the following procedure after installation, maintenance, or repair, before initiating motion.



DANGER

Initiating motion without fulfilling the following aspects, may increase the risk for injury or cause damage to the robot.

	Action
1	Remove all tools and foreign objects from the robot and its working area.
2	Verify that the robot is properly secured to its position by all screws, before it is powered up.
3	Verify that any safety equipment installed to secure the position or restrict the robot motion during service activity is removed.
4	Verify that the fixture and work piece are well secured, if applicable.
5	Verify that all safety equipment is installed, as designed for the application.
6	Verify that no personnel are inside the safeguarded space.
7	If maintenance or repair has been done, verify the function of the part that was maintained.
8	Verify the application in the operating mode manual reduced speed.

Collision risks



CAUTION

When programming the movements of the robot, always identify potential collision risks before initiating motion.

3.3.2 Lifting the robot

3.3.2.1 Lifting the robot by two people

General

This section describes how to lift the robot and move it by two people.



WARNING

The transportation brackets cannot be removed until the robot is secured to the foundation.

Grasping location

Position	Grasping location	Note
Inverted	<p>xx1800002814</p>	When the robot is inverted, grasp the robot with one hand supporting at the housing and the other hand holding the base.

Lifting and transporting the robot

	Action
1	<p> CAUTION</p> <p>The IRB 910INV weighs, IRB 910INV-3/0.35: 19 kg IRB 910INV-6/0.55: 22 kg and can be lifted by two people.</p> <p> CAUTION</p> <p>Do not grasp the ball screw during the lifting work, it may be damaged.</p>
2	Grasp the robot, see Grasping location on page 57 .
3	Lift the robot.

Continues on next page

3 Installation and commissioning

3.3.2.1 Lifting the robot by two people

Continued

	Action
4	<p>Move the robot to desired position.</p> <p> CAUTION</p> <p>Be careful so that the robot does not bump into something while lifting and transporting. It could damage the robot.</p>
5	<p>Secure the robot on a workbench according to section Orienting and securing the robot on page 68.</p>

3.3.2.2 Lifting robot with lifting accessories

Illustration - attaching the roundslings

IRB 910INV-3/0.35

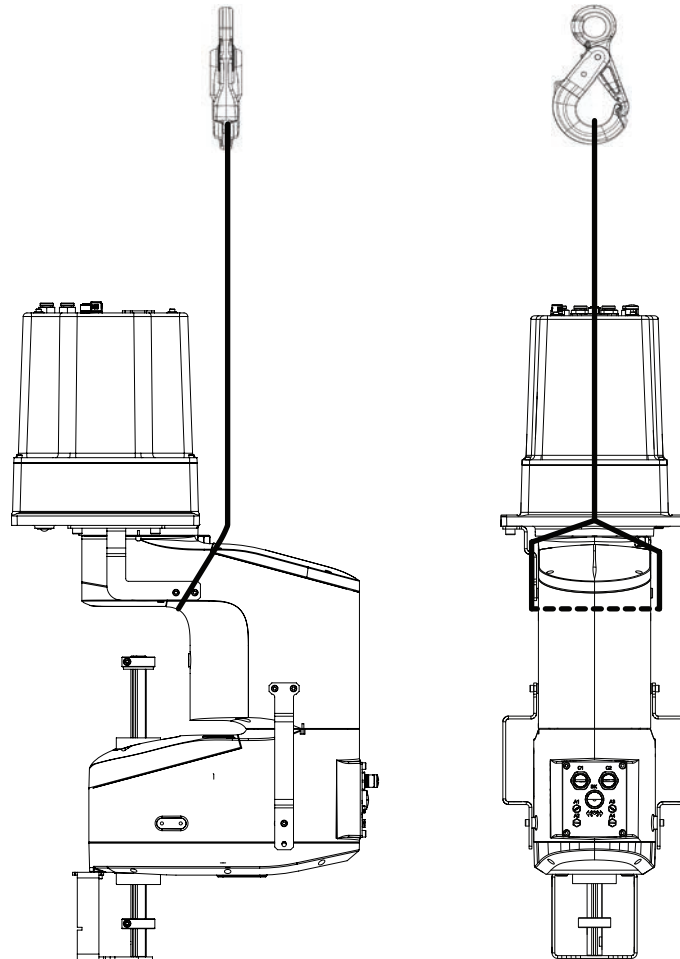

xx1800002810



DANGER

Attempting to lift a robot in any other position than the recommended lifting position may result in the robot tipping over, causing severe damage or injury.

Continues on next page

3 Installation and commissioning

3.3.2.2 Lifting robot with lifting accessories

Continued

IRB 910INV-6/0.55

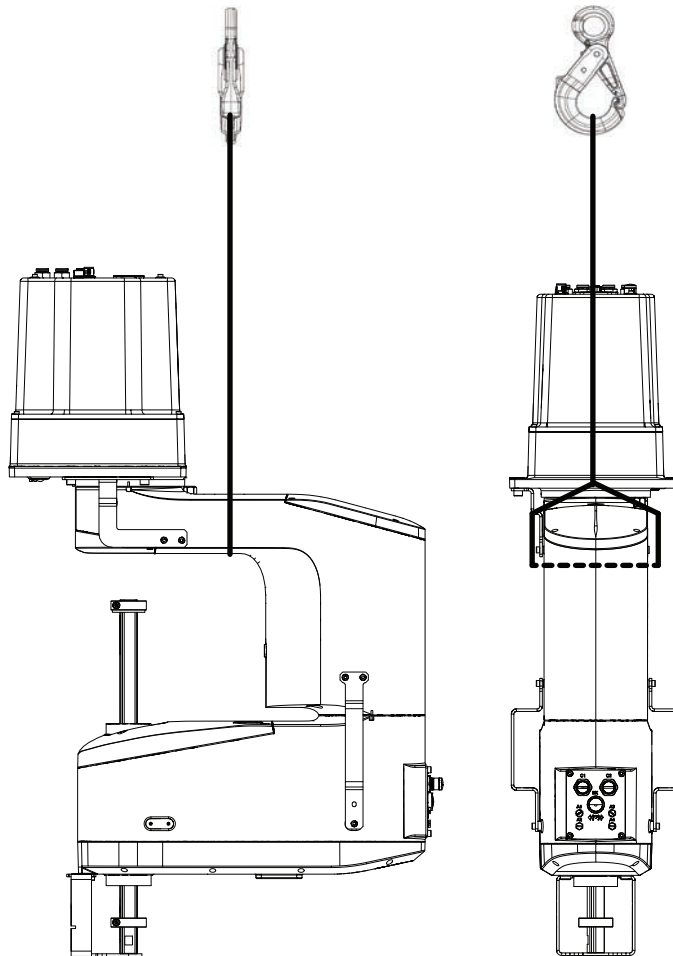

xx1800002811



DANGER

Attempting to lift a robot in any other position than the recommended lifting position may result in the robot tipping over, causing severe damage or injury.

Required tools and equipment

Equipment	Article number	Note
Overhead crane	-	
Roundsling, 3 m	-	Length: 3 m. Lifting capacity: 50 kg.

Lifting the robot







WARNING

The transportation brackets cannot be removed until the robot is secured to the foundation.

Continues on next page

Use this procedure to lift the robot.

	Action	Note
1	<p>Move the robot to the appropriate lifting position.</p> <p> WARNING</p> <p>The robot is mechanically unstable if not secured to the foundation.</p>	
2	<p> CAUTION</p> <p>For Clean Room robots, it is important not to rub against the paint of the robot while performing any service work on the robot.</p>	
3	<p> CAUTION</p> <p>The weight of the IRB 910INV robot is 22 kg All lifting accessories used must be sized accordingly.</p>	
4	<p> WARNING</p> <p>Personnel must not, under any circumstances, be present under the suspended load.</p>	

Continues on next page

3 Installation and commissioning

3.3.2.2 Lifting robot with lifting accessories

Continued

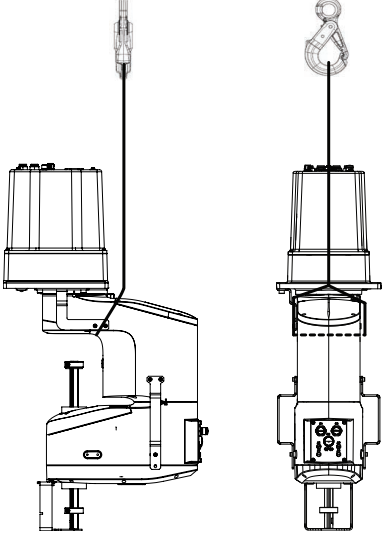
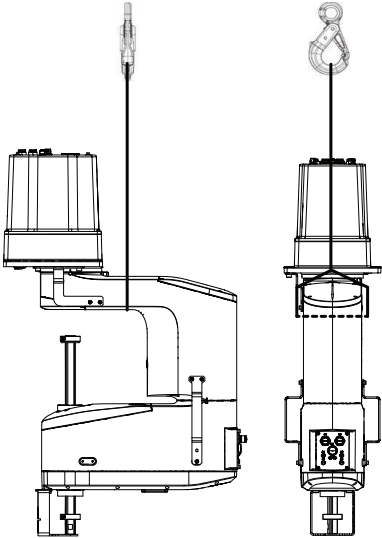
	Action	Note
5	Attach the lifting roundslings to the robot.	<p>Lifting capacity for the lifting chain is specified in Required tools and equipment on page 60.</p> <p>Valid for IRB 910INV-3/0.35</p>  <p>xx1800002810</p> <p>Valid for IRB 910INV-6/0.55</p>  <p>xx1800002811</p>
6	<p>Carefully stretch the roundslings by lifting the crane slowly.</p> <p>This prevents the robot from falling down when it is unfastened. Do not overstretch the roundslings if the robot is fastened because there is a risk of the robot being damaged.</p>	

Continues on next page

3 Installation and commissioning

3.3.2.2 Lifting robot with lifting accessories

Continued

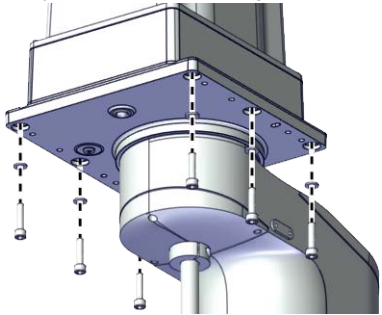
	Action	Note
7	Remove the robot attachment screws (if the robot is fastened).	<p>Screw: M6x25 (robot installation directly on foundation) (6 pcs)</p>  <p>xx1900000141</p>
8	Raise the overhead crane to lift the robot.	

3 Installation and commissioning

3.3.2.3 Lifting and rotating a suspended mounted or tilted manipulator

3.3.2.3 Lifting and rotating a suspended mounted or tilted manipulator

Introduction

How to lift and turn the robot to a suspended/inverted position using the turning accessory is described in the lifting instruction delivered with the turning accessory. Article numbers for the accessory and the instruction is specified in [Special tools on page 841](#). Any additional equipment required is specified in the instruction for the lifting accessory. Contact ABB for more information.

Illustration

xx insert an image

3.3.3 Manually releasing the brakes

Introduction to manually releasing the brakes

This section describes how to release the holding brakes for the axes motors.

Location of the brake release unit

The brake release unit is located as shown in the figure.

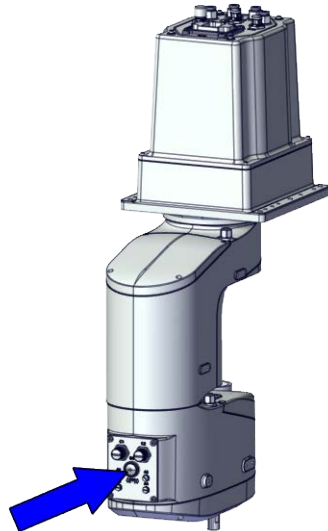

xx1800002815

Releasing the brakes

This procedure describes how to release the holding brakes when the robot is equipped with a brake release unit.



	Action	Note
1	 Note If the robot is not connected to the controller, power must be supplied to the connector R1.MP according to the section Supplying power to connector R1.MP on page 67 .	

Continues on next page

3 Installation and commissioning

3.3.3 Manually releasing the brakes

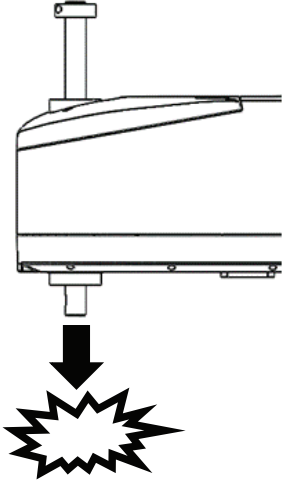

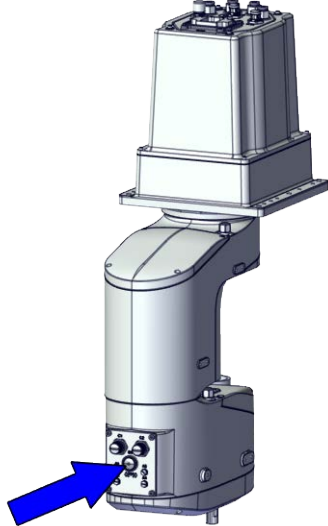
Continued

	Action	Note
2	<p> DANGER</p> <p>When releasing the holding brakes, the robot axes may move very quickly and sometimes in unexpected ways.</p> <p>Make sure no personnel is near or beneath the robot.</p>	<p>In the example below, with no arm load and in synchronization position, the gravity force from the ball screw will cause the axis-3 to move very quickly, when the brakes of the axis-3 motor are released.</p>  <p>xx1900000142</p>
3	<p>Release the holding brake of all axes by pressing the brake release button.</p> <p>The brake will be enable as soon as the button is released.</p> <p> WARNING</p> <p>Pressing the brake release button will release the holding brakes on all axes simultaneously.</p>	 <p>xx1800002815</p>

Continues on next page

Supplying power to connector R1.MP

If the robot is not connected to the controller, power must be supplied to connector R1.MP on the robot, in order to enable the brake release buttons.

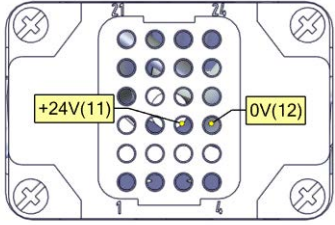
	Action	Note
1	 <p>DANGER</p> <p>Incorrect connections, such as supplying power to the wrong pin, may cause all brakes to be released simultaneously and instantly!</p>	
2	<p>Supply</p> <ul style="list-style-type: none"> • 0V on pin 12. • 24V on pin 11.  <p>Note</p> <p>Do not interchange the 24V and 0V pins. If they are mixed up, damage can be caused to internal electrical components.</p>	 <p>xx1900000100</p>
3	<p>Use the brake releasing button as described in Releasing the brakes on page 65.</p>	

3 Installation and commissioning

3.3.4 Orienting and securing the robot

3.3.4 Orienting and securing the robot

General

This section describes how to orient and secure the robot to the base plate or foundation in order to run the robot safely.

Attachment screws



The table below specifies the type of securing screws and washers to be used for securing the robot to the base plate/foundation.

Suitable screws	M6x25 (robot installation directly on foundation)
Quantity	6 pcs
Quality	10.9
Suitable washer	12 x 6.4 x 1.6, steel hardness class 300HV
Guide pins	2 pcs, D5x20, ISO 2338 - 5m6x20 - A1
Tightening torque	11 Nm±1.1 Nm
Length of thread engagement	Minimum 14 mm for ground with material yield strength 150 MPa
Level surface requirements	0.1/500 mm ⁱ

ⁱ See [Requirements, foundation on page 39](#).

Orienting and securing the robot

Use this procedure to orient and secure the robot.

	Action	Note
1	Make sure the installation site for the robot conforms to the specifications in section Technical data on page 37 .	
2	Prepare the installation site with attachment holes. The foundation surface must be clean and unpainted.	The hole configuration of the base is shown in the figure in Hole configuration, base on page 69 .
3	 CAUTION The weight of the IRB 910INV robot is IRB 910INV-3/0.35: 19 kg IRB 910INV-6/0.55: 22 kg All lifting accessories used must be sized accordingly.	
4	 CAUTION When the robot is put down after being lifted or transported, there is a risk of it tipping, if not properly secured.	
5	Lift the robot.	See Lifting the robot on page 57 .
6	Fit two pins to the holes in the base.	2 pcs, D5x20, ISO 2338 - 5m6x20 - A1

Continues on next page

3 Installation and commissioning

3.3.4 Orienting and securing the robot

Continued

	Action	Note
7	Guide the robot gently, using the attachment screws while lowering it into its mounting position.	Make sure the robot base is correctly fitted onto the pins.
8	Fit the securing screws and washers in the attachment holes of the base.	Screws: M6x25 (robot installation directly on foundation), 6 pcs, quality 10.9 Washers: 12 x 6.4 x 1.6, steel hardness class 300HV
9	Tighten the bolts in a crosswise pattern to ensure that the base is not distorted.	Tightening torque: 11 Nm±1.1 Nm

Hole configuration, base

This illustration shows the hole configuration used when securing the robot.

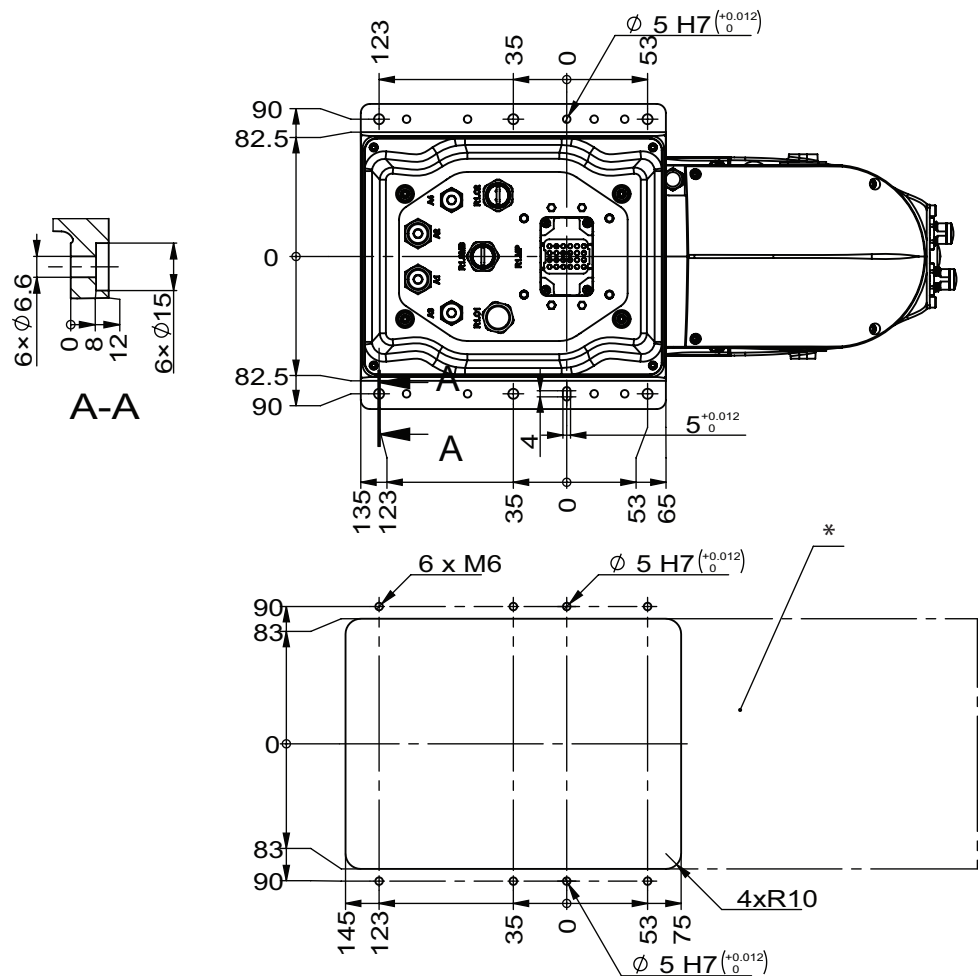

xx1800002817

* Maintenance window: Opening to access inner arm's cover is recommended.

3 Installation and commissioning

3.3.5 Loads fitted to the robot, stopping time and braking distances

3.3.5 Loads fitted to the robot, stopping time and braking distances

Define loads carefully

Any loads mounted on the robot must be defined correctly and carefully (with regard to the position of center of gravity and mass moments of inertia) in order to avoid jolting movements and overloading motors, gears and structure.



CAUTION

Incorrectly defined loads may result in operational stops or major damage to the robot.

Load diagrams, permitted extra loads (equipment) and their positions are specified in the product specification. The loads must be defined in the software.

Stopping time and braking distances

The performance of the motor brake depends on if there are any loads attached to the robot.

See the product specification for the robot, listed in [References on page 10](#).

3.3.6 Lamp

3.3.6.1 Lamp on the robot

Description

A lamp with a yellow fixed light is installed on the robot.

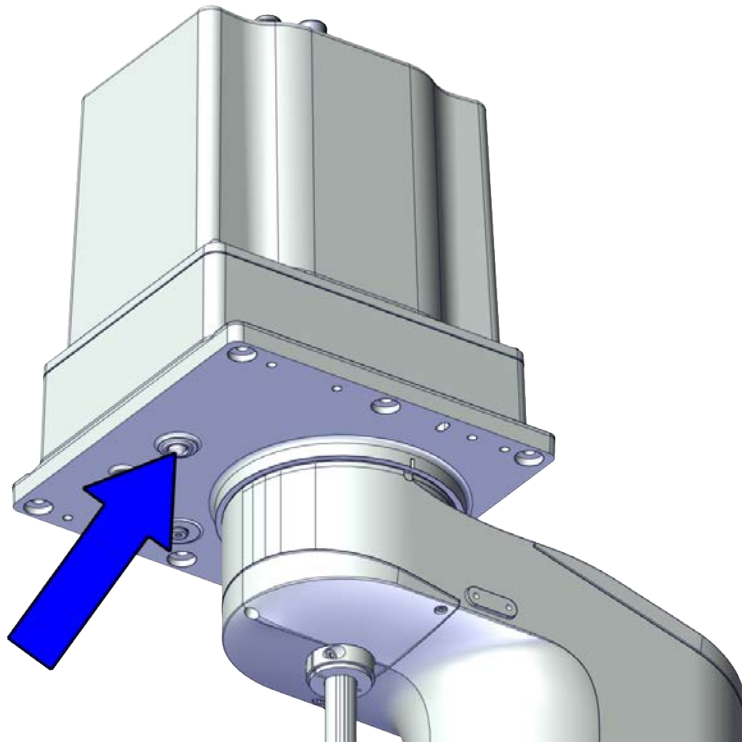

xx2100002508

Function

The lamp is active in MOTORS ON mode.



Note

This function is NOT valid when connecting to OmniCore E10.

Further information

Further information about the MOTORS ON/MOTORS OFF mode may be found in the product manual for the controller.

3 Installation and commissioning

3.3.6.2 Installation of signal lamp (option)

3.3.6.2 Installation of signal lamp (option)



Description

A signal lamp with a yellow fixed light can be mounted in the cell or any other visible location, and driven by I/O signal or MON_LAMP signal from the controller.



Function

The lamp is active in MOTORS ON mode.

Installation of signal lamp from I/O signal

	Action
1	 DANGER Make sure that all supplies for electrical power, hydraulic pressure, and air pressure are turned off.
2	For robots with OmniCore C line Connect the lamp cable connector to the local I/O connector on the controller.  Note The local I/O connectors provides 16 digital output signals for use.
3	For robots with OmniCore E line Connect the lamp cable connector to the I/O connector on the controller.  Note The I/O connectors provides 8 digital output signals for use.
4	Configure the lamp by adding a <i>System Output</i> type signal with status set to <i>Motors On State</i> .
5	The lamp is now ready for use and is lit in MOTORS ON mode.

Installation of signal lamp from MON_LAMP signal

	Action
1	 DANGER Make sure that all supplies for electrical power, hydraulic pressure, and air pressure are turned off.
2	For robots with OmniCore C line Connect the lamp cable connector to the X15 connector on the controller.  Note The X15 connector provides MON_LAMP output signals for use. For more details, see chapter <i>Descriptions for connectors</i> in OmniCore product manuals.

Continues on next page

	Action
3	<p>For robots with OmniCore E line Connect the lamp cable connector to the MON connector on the controller.</p> <p> Note The MON connector provides MON_LAMP output signals for use. For more details, see chapter <i>Descriptions for connectors</i> in OmniCore product manuals.</p>
4	The lamp is now ready for use and is lit in MOTORS ON mode.

Further information

Further information about the MOTORS ON/MOTORS OFF mode may be found in the product manual for the controller.

Further information about how to set up I/O system may be found in *Technical reference manual - System parameters*.

3 Installation and commissioning

3.3.7 Fitting equipment on the robot (robot dimensions)

3.3.7 Fitting equipment on the robot (robot dimensions)

Attachment holes and dimensions

Extra loads can be mounted on robot. Definitions of dimensions and masses are shown in the following figures. The robot is supplied with holes for fitting extra equipment.

Maximum allowed arm load depends on center of gravity of arm load and robot payload.

Holes for fitting extra equipment of IRB 910INV-3/0.35

Robots with protection class IP30 (option 3350-300)

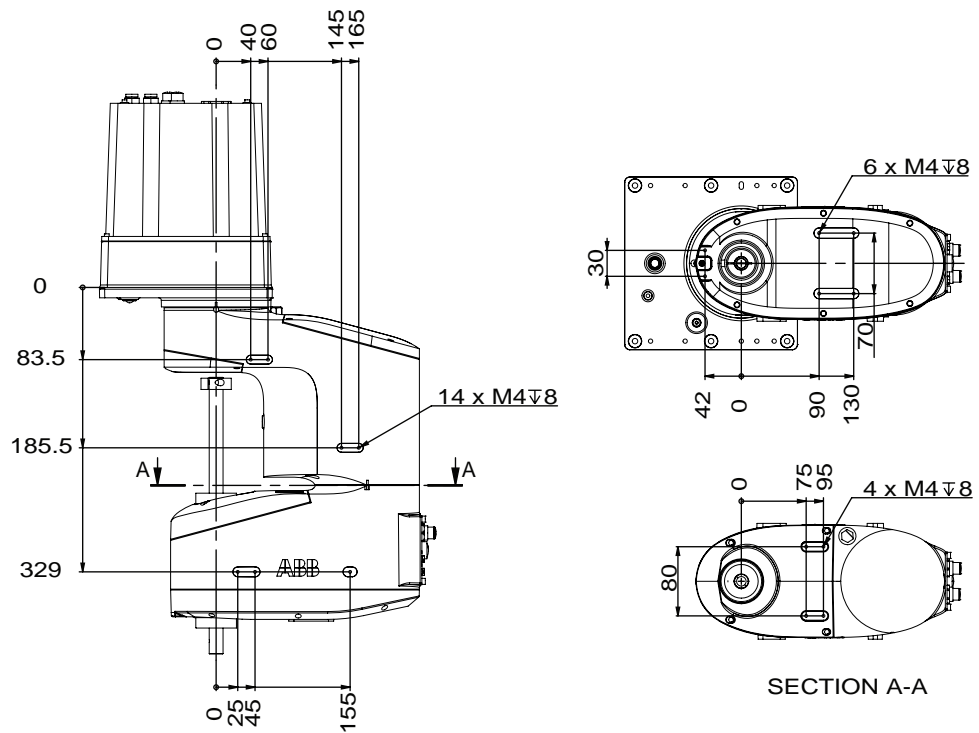

xx1900000218

Continues on next page

3 Installation and commissioning

3.3.7 Fitting equipment on the robot (robot dimensions)

Continued

Robots with protection class IP54 (option 3350-540) or with protection type Clean Room (option 3351-1)

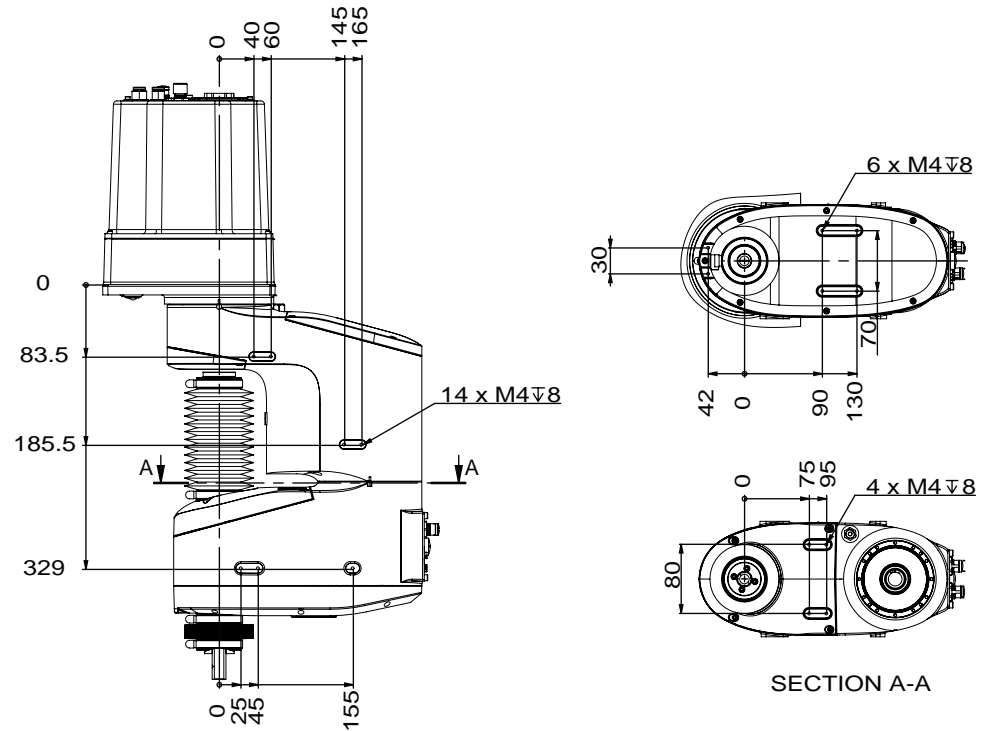

xx1900001542

Holes for fitting extra equipment of IRB 910INV-6/0.55

Robots with protection class IP30 (option 3350-300)

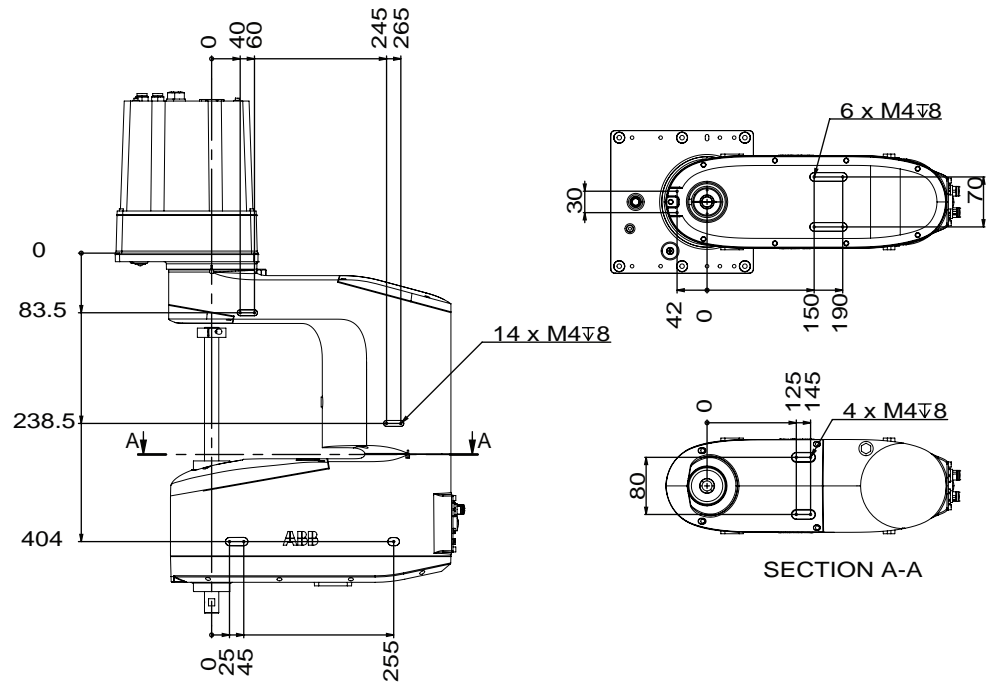

xx1900000219

Continues on next page

3 Installation and commissioning

3.3.7 Fitting equipment on the robot (robot dimensions)

Continued

Robots with protection class IP54 (option 3350-540) or with protection type Clean Room (option 3351-1)

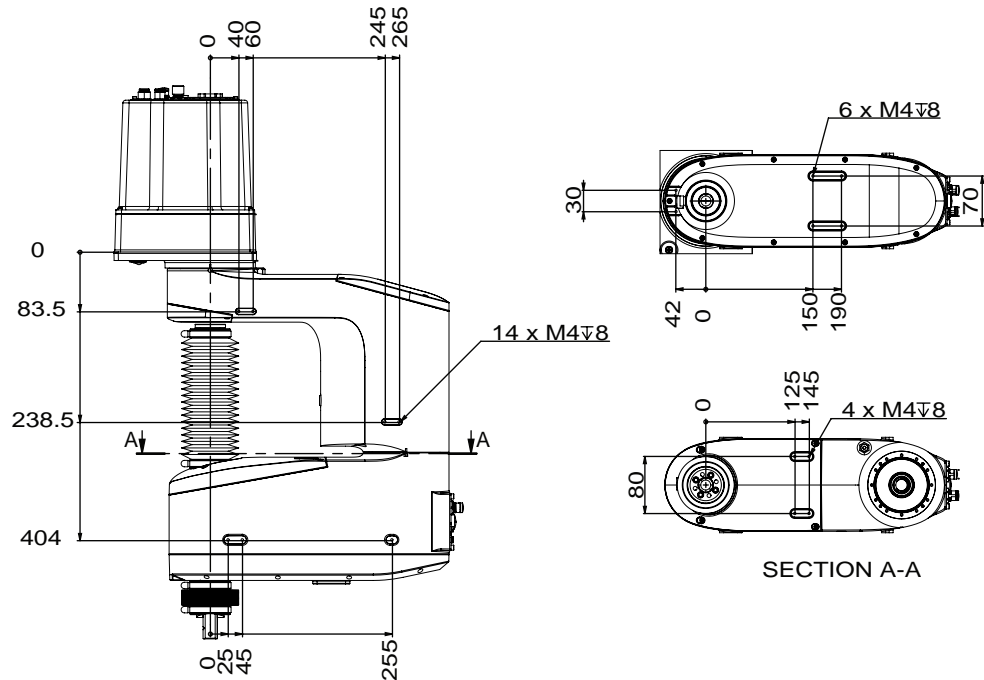

xx1900001543

Fitting of end effector to the ball screw spline shaft

An end effector can be attached to the lower end of the shaft of the ball screw spline unit. The dimensions for fitting the end effector is shown in the following figure.



Note

Mounting of other equipment on the IRB 910INV may damage the gearboxes.

Continues on next page

3 Installation and commissioning

3.3.7 Fitting equipment on the robot (robot dimensions)

Continued

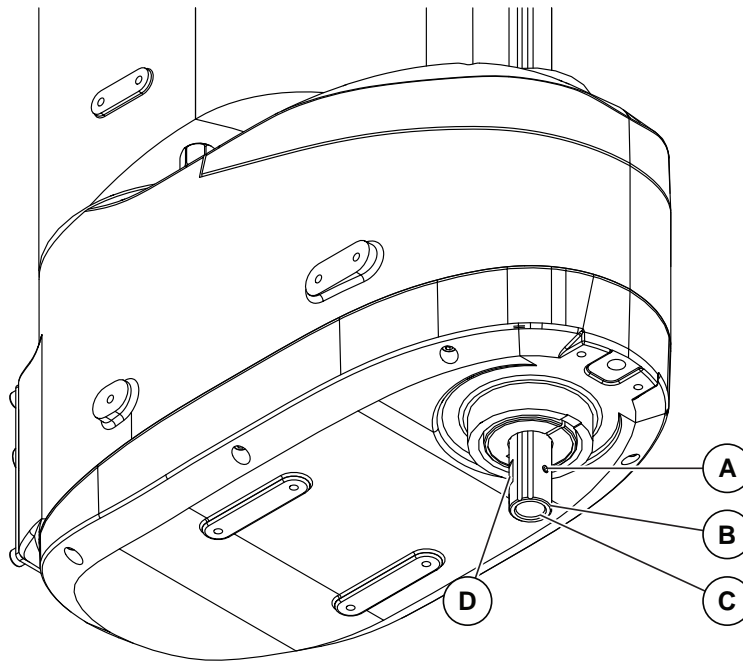

xx1800002819

A	Conical hole
B	Shaft diameter
C	Through hole
D	Flat cut

Continues on next page

3 Installation and commissioning

3.3.7 Fitting equipment on the robot (robot dimensions)

Continued

End effector flange of IRB 910INV-3/0.35

Robots with protection class IP30 (option 3350-300)

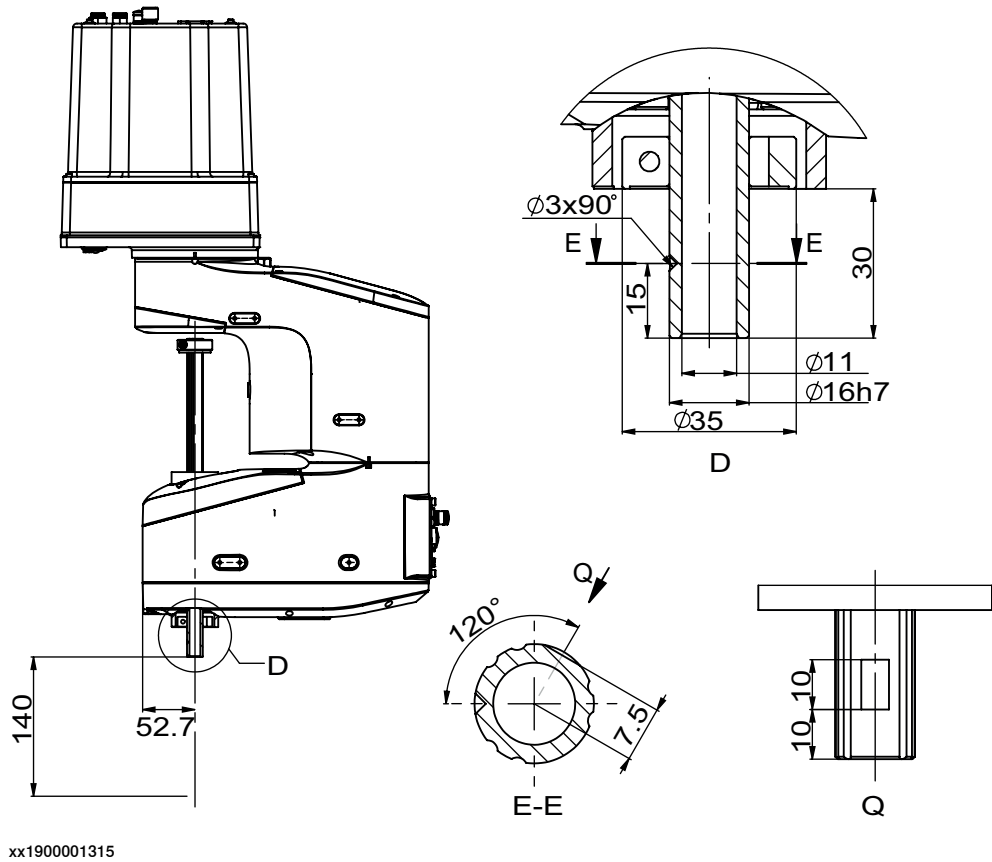

Continues on next page

3 Installation and commissioning

3.3.7 Fitting equipment on the robot (robot dimensions)

Continued

Robots with protection class IP54 (option 3350-540) or with protection type Clean Room (option 3351-1)

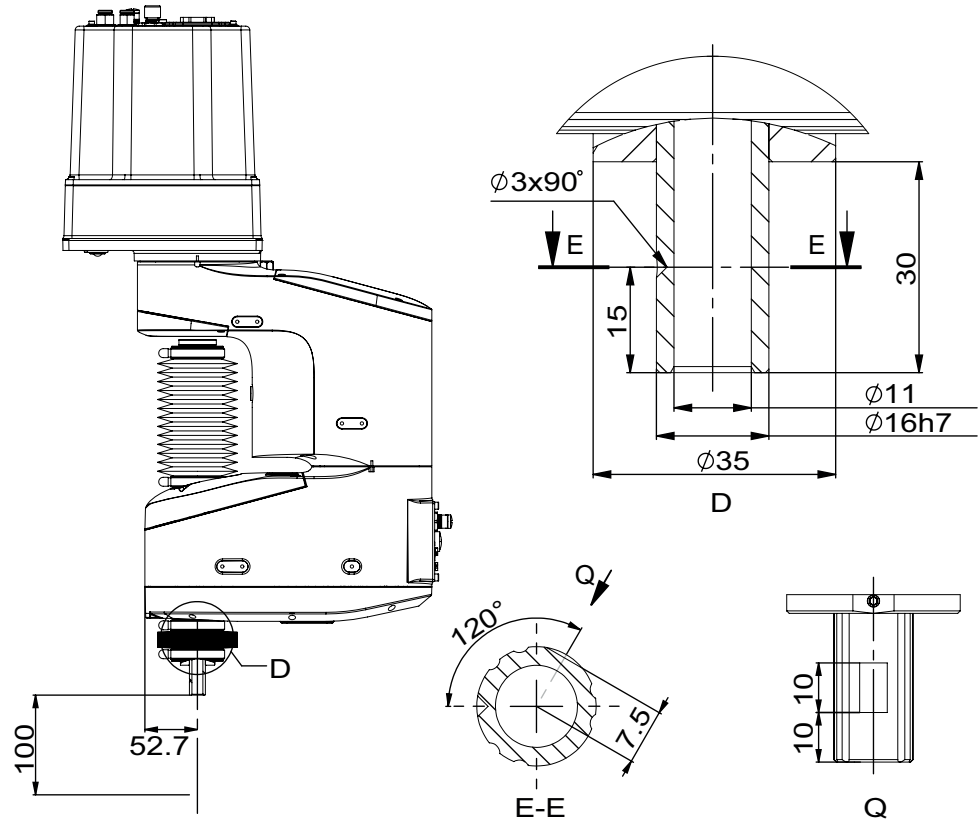

xx1900001544

Continues on next page

3 Installation and commissioning

3.3.7 Fitting equipment on the robot (robot dimensions)

Continued

End effector flange of IRB 910INV-6/0.55

Robots with protection class IP30 (option 3350-300)

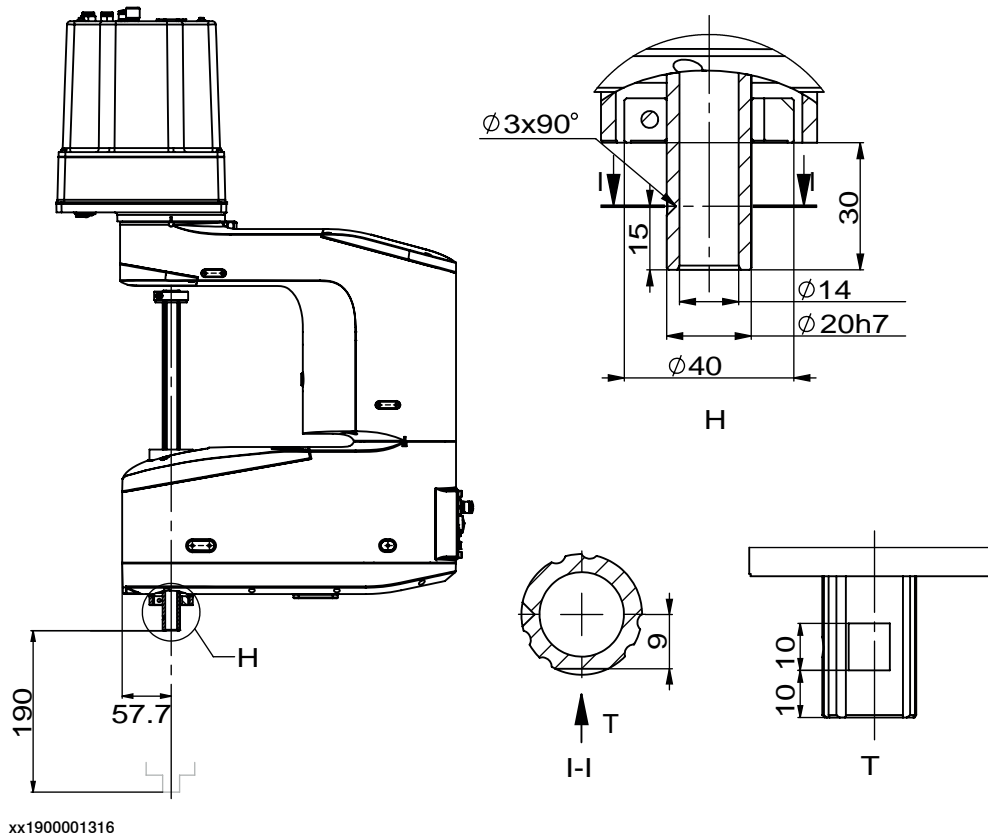

Continues on next page

3 Installation and commissioning

3.3.7 Fitting equipment on the robot (robot dimensions)

Continued

Robots with protection class IP54 (option 3350-540) or with protection type Clean Room (option 3351-1)

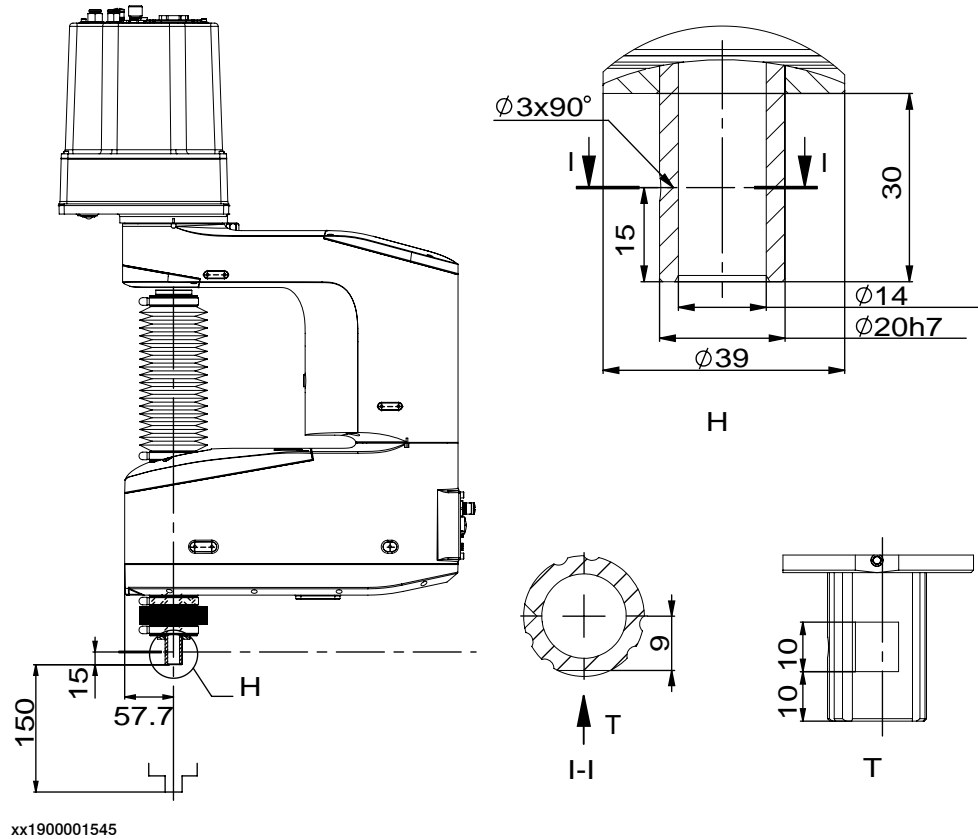

Fastener quality

When fitting tools on the tool flange, only use screws with quality 12.9. For other equipment use suitable screws and tightening torque for your application.

3 Installation and commissioning

3.4.1 Adjusting the working range

3.4 Restricting the working range

3.4.1 Adjusting the working range

Reasons for adjusting the manipulator working range

The working range of each manipulator axis is configured in the software. If there is a risk that the manipulator may collide with other objects at installation site, its working space should be limited. The manipulator must always be able to move freely within its entire working space.

Working range configurations

The parameter values for the axes working range can be altered within the allowed working range and according to available options for the robot, either to limit or to extend a default working range. Allowed working ranges and available options for each manipulator axis are specified in [Working range on page 43](#).

Mechanical stops on the manipulator

Mechanical stops are and can be installed on the manipulator as limiting devices to ensure that the manipulator axis does not exceed the working range values set in the software parameters.



Note

The mechanical stops are only installed as safety precaution to physically stop the robot from exceeding the working range set. A collision with a mechanical stop always requires actions for repair and troubleshooting.

Axis	Fixed mechanical stop ⁱ	Movable mechanical stop ⁱⁱ
Axis 1	no	no
Axis 2	no	no
Axis 3	yes	yes
Axis 4	no	no

ⁱ Part of the casting or fixed on the casting and can not /should not be removed.

ⁱⁱ Can be installed in a different position to ensure a reduced working range.

3.4.2 Mechanically restricting the working range

Location of the mechanical stops

Only the axis 3 of the robots with protection class IP30 has two replaceable mechanical stops.

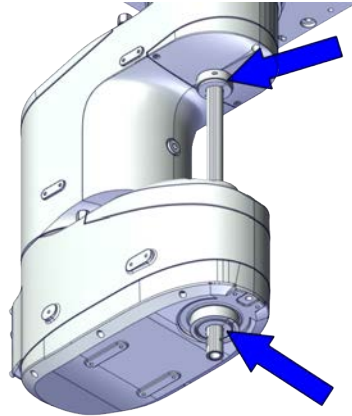

xx1800002820

Required spare parts



Note

The spare part numbers that are listed in the table can be out of date. See the latest spare parts of the IRB 910INV via myABB Business Portal, www.abb.com/myABB.

Spare part	Article number	Note
Mechanical-Stop top, D16	3HAC073060-001	Used for IRB 910INV-3/0.35
Mechanical-Stop top, D20	3HAC073068-001	Used for IRB 910INV-6/0.55
Mechanical-Stop bottom, D16	3HAC073061-001	Used for IRB 910INV-3/0.35
Mechanical-Stop bottom, D20	3HAC073069-001	Used for IRB 910INV-6/0.55

Replacement of the axis-3 mechanical stop

For more details about replacing the axis-3 mechanical stop, see [Replacing the mechanical stopper on page 377](#).

3 Installation and commissioning

3.5.1 Robot cabling and connection points

3.5 Electrical connections

3.5.1 Robot cabling and connection points

Introduction

Connect the robot and controller to each other after securing them to the foundation. The lists below specify which cables to use for each respective application.



DANGER

Turn off the main power before connecting any cables.



CAUTION

Verify that the robot serial number is according to the number(s) in the *Declaration of Incorporation (DoI)*.

Main cable categories

The following table specifies cabling categories between the robot and the controller. Some of the cabling belong to optional applications.

Cable category	Description
Robot cables	Handles power supply to and control of the robot's motors as well as feedback from the serial measurement board. Specified in the table Robot cables on page 84 .
Customer cables	Handles communication with equipment fitted on the robot by the customer, low voltage signals and high voltage power supply + protective ground. The customer cables also handle databus communication. The customer cables also include the air hose. See the product manual for the controller, see document number in References on page 10 .
Air hoses	The hose for compressed air is integrated with the manipulator cable harness.

Robot cables

These cables are included in the standard delivery. They are completely pre-manufactured and ready to plug in.

Cable sub-category	Description	Connection point, cabinet	Connection point, robot
Robot cables, power	Transfers drive power from the drive units in the control cabinet to the robot motors.	X1	R1.MP ⁱ
Robot cable, signals	Transfers resolver data from and power supply to the serial measurement board.	X2	R1.SMB

ⁱ An O-ring is needed for the robots with protection type Clean Room and protection class IP54.

Continues on next page



Note

Install the O-ring (3HAB3772-19) for the haring connector when connect the power cable for the robots with protection type Clean Room and protection class IP54.

Robot cable, power

Power cable length	Article number
Power cable, straight connector, 3 m	3HAC077245-001
Power cable, straight connector, 7 m	3HAC077245-002
Power cable, straight connector, 15 m	3HAC077245-003
Power cable, angled connector, 3 m	3HAC077247-001
Power cable, angled connector, 7 m	3HAC077247-002
Power cable, angled connector, 15 m	3HAC077247-003

Robot cable, signals

Signal cable length	Article number
Signal cable, shielded: 3 m	3HAC067446-001
Signal cable, shielded: 7 m	3HAC067446-002
Signal cable, shielded: 15 m	3HAC067446-003

Bending radius for static floor cables

The minimum bending radius is 10 times the cable diameter for static floor cables.

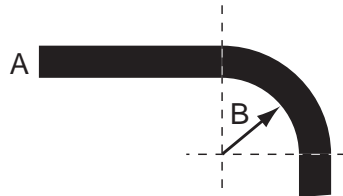

xx1600002016

A	Diameter
B	Diameter x10

Continues on next page

3 Installation and commissioning

3.5.1 Robot cabling and connection points

Continued

Grounding and bonding point on manipulator

There is a grounding/bonding point on the manipulator base. The grounding/bonding point is used for potential equalizing between control cabinet, manipulator and any peripheral devices.

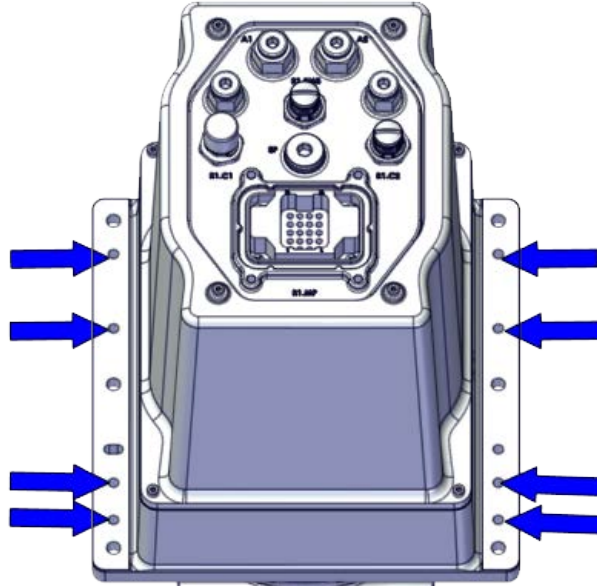

xx190000143

Customer cables - CP/CS cable

CP/CS cable length	Article number ⁱ
3 m	3HAC067449-001
7 m	3HAC067449-002
15 m	3HAC067449-003

ⁱ It is recommended to always use the CP/CS cable provided by ABB. If users still require to do wiring by their own, make sure to use R1.C1 connector in M12 A-code 12p female type. It is the responsibility of the users to guarantee the safety of the system when self-prepared cables and connectors are used.

Customer cables - Ethernet floor cable

Ethernet floor cable length	Article number ⁱ
7 m	3HAC067447-002
15 m	3HAC067447-003

ⁱ It is recommended to always use the Ethernet floor cable provided by ABB. If users still require to do wiring by their own, make sure to use R1.C2 connector in M12 X-code male type. It is the responsibility of the users to guarantee the safety of the system when self-prepared cables and connectors are used.

3.5.2 Customer connections

Introduction to customer connections

The cables for customer connection are integrated in the robot and the connectors are placed at the outer arm and base. There are two connectors C1/C2 at the outer arm. Corresponding connector R1.C1/R1.C2 are located at the base.

Hose for compressed air is also integrated into the manipulator. There are 4 inlets at the base (R1/8") and 4 outlets (M5) on the outer arm.

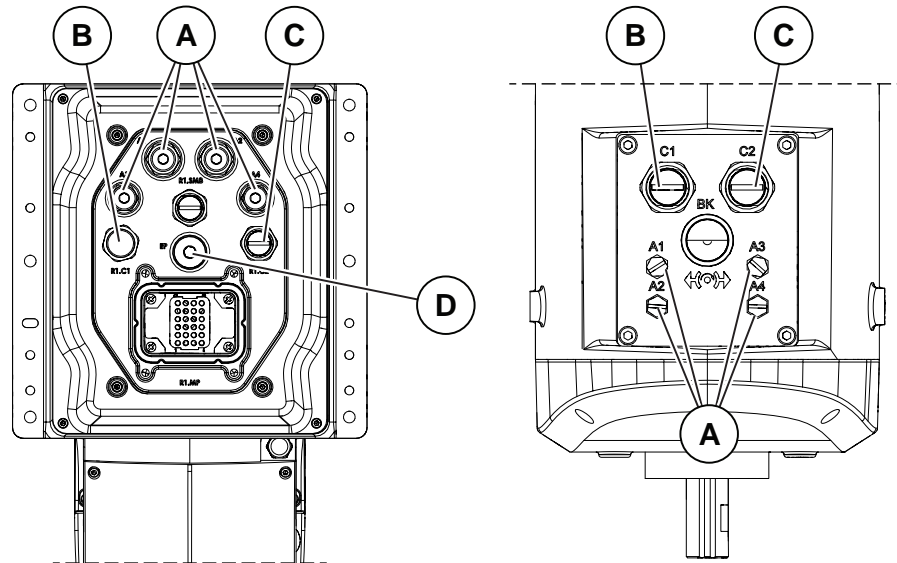

xx1800002821

Position	Connection	Description	Number	Value
A	Air	Max. 6 bar	4	Air hose with outer diameter 4 mm, 2 pcs Air hose with outer diameter 6 mm, 2 pcs
B	C1	Customer power/signal	8 wires ⁱ	30 V, 1.5 A
C	C2	Customer power/signal or ethernet	8 wires	30 V, 1 A or 1 Gbits/s
D	EP	Exhaust port ⁱⁱ	1	Φ10 , 7-9L/min ⁱⁱⁱ

ⁱ The connector has 12 pins. Only pins 1 to 8 are available for use.

ⁱⁱ Only available for protection type Clean Room.

ⁱⁱⁱ To avoid the deformation of bellows, reduce the air flow if necessary.

Connector kits

Connector kits, base

R1.C1 and R1.C2 connectors on the base are parts of the CP/CS cable and Ethernet floor cable, respectively. For details about the robot cabling, see [Robot cabling and connection points on page 84](#).

Continues on next page

3 Installation and commissioning

3.5.2 Customer connections

Continued

Connector kits, outer arm

The table describes the CP/CS and Ethernet (if any) connector kits for the outer arm.

Position	Description	Art. no.	
Connector kits	CP/CS	M12 CP/CS Male straight connector kits	3HAC066098-001
		M12 CP/CS Male angled connector kits	3HAC066099-001
	Ethernet	M12 Ethernet Cat5e Male straight connector kits	3HAC067413-001
		M12 Ethernet Cat5e Male angled connector kits	3HAC067414-001

Protection covers

Protection covers for water and dust proofing

Protection covers are delivered together with the robot and must be well fitted to the connectors in any application requiring water and dust proofing.

Always remember to refit the protection covers after removing them.

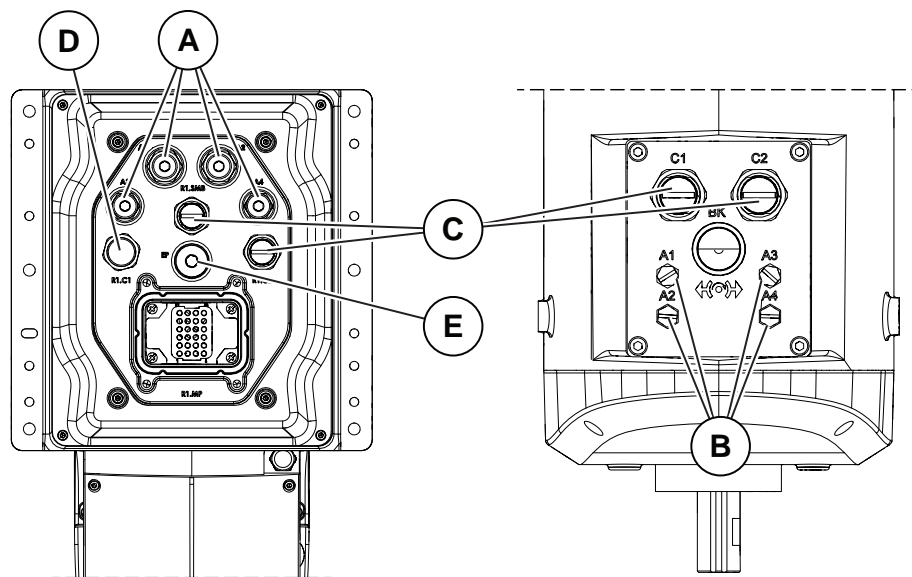

xx1900000149

A	Protection covers for air hose connector on the base
B	Protection covers for air hose connector on the process hub
C	Protection covers for C2/SMB connector on the base and C1/C2 connector on the process hub
D	Protection cover for C1 connector on the base
E	Protection plug for exhaust port connector on the base ⁱ

ⁱ Only available for protection type Clean Room.

3.6 Start of robot in cold environments

Introduction

This section describes how to start the robot in a cold environment if it is not starting the normal way.

Problems with starting the robot

Event message from Motion Supervision

Use this procedure if an event message indicates a problem with Motion supervision at start-up. More information about Motion Supervision is found in *Technical reference manual - System parameters*.

	Action	Note
1	Turn off Motion Supervision.	
2	Start the robot.	
3	When the robot has reached normal working temperature, the Motion Supervision can be turned on again.	

Robot stopping with other event message

Use this procedure if the robot is not starting.

	Action	Note
1	Start the robot with its normal program but with reduced speed.	The speed can be regulated with the RAPID instruction <code>VelSet</code> .

Adjusting the speed and acceleration during warm-up

Depending on how cold the environment is and what program is being used, the speed might need to be ramped up until reached maximum. The table shows examples of how to adjust the speed:

Work cycles	AccSet	Speed/velocity
3 Work cycles	20, 20	v100 (100 mm/s)
5 Work cycles	40, 40	v400 (400 mm/s)
5 Work cycles	60, 60	v600 (600 mm/s)
5 Work cycles	100, 100	v1000 (1000 mm/s)
More than 5 Work cycles	100, 100	Max.

If the program consists of large wrist movements, it is possible that the reorientation velocity, which is always high in predefined velocities, needs to be included in the ramping up.

3 Installation and commissioning

3.7 Test run after installation, maintenance, or repair

3.7 Test run after installation, maintenance, or repair

Safe handling

Use the following procedure after installation, maintenance, or repair, before initiating motion.



DANGER

Initiating motion without fulfilling the following aspects, may increase the risk for injury or cause damage to the robot.

	Action
1	Remove all tools and foreign objects from the robot and its working area.
2	Verify that the robot is properly secured to its position by all screws, before it is powered up.
3	Verify that any safety equipment installed to secure the position or restrict the robot motion during service activity is removed.
4	Verify that the fixture and work piece are well secured, if applicable.
5	Verify that all safety equipment is installed, as designed for the application.
6	Verify that no personnel are inside the safeguarded space.
7	If maintenance or repair has been done, verify the function of the part that was maintained.
8	Verify the application in the operating mode manual reduced speed.

Collision risks



CAUTION

When programming the movements of the robot, always identify potential collision risks before initiating motion.

4 Maintenance

4.1 Introduction

Structure of this chapter

This chapter describes all the maintenance activities recommended for the IRB 910INV.

It is based on the maintenance schedule found at the beginning of the chapter. The schedule contains information about required maintenance activities including intervals, and refers to procedures for the activities.

Each procedure contains all the information required to perform the activity, including required tools and materials.

The procedures are gathered in different sections and divided according to the maintenance activity.

Safety information

Observe all safety information before conducting any service work.

There are general safety aspects that must be read through, as well as more specific safety information that describes the danger and safety risks when performing the procedures. Read the chapter [Safety on page 15](#) before performing any service work.

The maintenance must be done by qualified personnel in accordance with the safety requirements set forth in the applicable national and regional standards and regulations.



Note

If the IRB 910INV is connected to power, always make sure that the IRB 910INV is connected to protective earth and a residual current device (RCD) before starting any maintenance work.

For more information see:

- *Product manual - OmniCore C30*
- *Product manual - OmniCore C90XT*
- *Product manual - OmniCore E10*
- [Robot cabling and connection points on page 84.](#)

4 Maintenance

4.2 Service Information System (SIS)

4.2 Service Information System (SIS)

General

Service Information System (SIS) is a software function within the robot controller, which simplifies maintenance of the robot system. It supervises the operating time and mode of the robot, and alerts the operator when a maintenance activity is scheduled.

Troubleshooting

The SIS function *Gearbox* is available for estimating the service interval (remaining lifetime) of the gearboxes of a robot. Such information of the ball screw spline unit of the IRB 910INV is reported as **axis 3** in the SIS system. When a service message is reported for axis 3 of the IRB 910INV, an inspection on the ball screw spline unit is required.

For more information about the SIS function, see *Operating manual - Service Information System*.

4.3 Maintenance schedule and expected component life

4.3.1 Specification of maintenance intervals

Introduction

The intervals are specified in different ways depending on the type of maintenance activity to be carried out and the working conditions of the IRB 910INV:

- Calendar time: specified in months regardless of whether the system is running or not.
- Operating time: specified in operating hours. More frequent running means more frequent maintenance activities.
- SIS: specified by the robot's SIS (Service Information System). A typical value is given for a typical work cycle, but the value will differ depending on how hard each part is run.

The SIS used in OmniCore is further described in the *Operating manual - OmniCore*.

Robots with the functionality *Service Information System* activated can show active counters in the device browser in RobotStudio, or on the FlexPendant.

4 Maintenance

4.3.2 Maintenance schedule

4.3.2 Maintenance schedule

Scheduled and non-predictable maintenance

The robot must be maintained regularly to ensure proper function. The maintenance activities and intervals are specified in the table below.

Non-predictable situations also give rise to inspections of the robot. Any damages must be attended to immediately!

Life of each component

The inspection intervals *do not* specify the life of each component. Values for these are specified in the section [Expected component life on page 96](#)

Maintenance schedule

Maintenance activities	Regularly	Every 12 months	Every 36 months	Every 20,000 hours ⁱ	Reference
Cleaning the robot	x				Cleaning the IRB 910INV on page 97
Inspecting the robot	x				Check for abnormal wear or contamination.
Inspecting the robot harness	x ⁱⁱ				Inspecting the robot cabling on page 101
Inspecting the information labels		x			Inspecting the information labels on page 99
Inspecting the ball screw spline unit	x				Inspecting the ball screw spline unit on page 102
Inspecting the mechanical stop	x				Inspecting axis-3 mechanical stops on page 105
Inspecting the bellows	x				Inspecting the bellows on page 108
Inspecting the timing belt		x			Inspecting timing belts on page 111
Lubricating the ball screw spline unit	x ⁱⁱⁱ				Lubricating the ball screw spline unit on page 114
Replacing the SMB battery pack			x		Replacing the battery pack on page 116
Running the <i>Brake Check</i> routine ^{iv}	x ^v				Recommended to robots without the SafeMove option. See <i>Operating manual - OmniCore</i> .
Running the <i>Cyclic Brake Check</i> routine ^{iv}	x ^v				Recommended to robots with the SafeMove option. See <i>Application manual - Functional safety and SafeMove</i> .

Continues on next page

Maintenance activities	Regularly	Every 12 months	Every 36 months	Every 20,000 hours ⁱ	Reference
Overhaul of complete robot				x	

- i Operating hours counted by the DTC = Duty time counter.
- ii Replace when damage or cracks is detected or life limit is approaching that specified in section [Expected component life on page 96](#).
- iii Inspect the grease condition on ball screw spline unit frequently and lubricate the unit if any of grease degradation (including but not limited to discoloration or dry-out) or insufficiency is observed. Alternatively, lubricate the ball screw spline unit regularly depending on the application condition.
- iv Not needed separately if already included in the application.
- v Recommended test interval is within the range 8-48 hours.

4 Maintenance

4.3.3 Expected component life

4.3.3 Expected component life

Expected life depends on usage

The expected life of a specific component of the robot can vary greatly depending on how hard it is run.

Expected component life

Component	Expected life	Note
Cable harness, normal usage ⁱ	20000 hours ⁱⁱ	
Cable harness, extreme usage ⁱⁱⁱ	20000 hours ⁱⁱ	
Gearboxes	20000 hours	

ⁱ Examples of "normal usage" in regard to movement: most material handling applications and limited use of bending backwards mode of axis 3.

ⁱⁱ Severe chemical or thermal environments, or similar environments, can result in shortened life expectancy.

ⁱⁱⁱ Examples of "extreme usage" in regard to movement: press tending, very severe palletizing applications, major use of axis 1 movement and major use of bending backwards of axis 3.

4.4 Cleaning activities

4.4.1 Cleaning the IRB 910INV

General

To secure high uptime it is important that the IRB 910INV is cleaned regularly. The frequency of cleaning depends on the environment in which the manipulator works. Different cleaning methods are allowed depending on the type of protection of the IRB 910INV.



Note

Always verify the protection type of the robot before cleaning.



WARNING

Turn off all electrical power supplies to the robot before starting the cleaning.

Special cleaning considerations

This section specifies some special considerations when cleaning the robot.

- Always use cleaning equipment as specified. Any other cleaning equipment may shorten the life of the robot.
- Always check that all protective covers are fitted to the robot before cleaning.
- Do not point the water jet at connectors, joints, sealings or gaskets.
- Do not use compressed air to clean the robot.
- Do not use solvents that are not approved by ABB to clean the robot.
- Do not remove any covers or other protective devices before cleaning the robot.

Cleaning methods

The following table defines what cleaning methods are allowed for ABB manipulators depending on the protection type.

Protection type	Cleaning method			
	Vacuum cleaner	Wipe with cloth	Rinse with water	High pressure water, steam or spray
Standard IP30	Yes	Yes. With light cleaning detergent.	No	No
IP54 (option)	Yes	Yes. With light cleaning detergent.	No	No

Continues on next page

4 Maintenance

4.4.1 Cleaning the IRB 910INV

Continued

Protection type	Cleaning method			
	Vacuum cleaner	Wipe with cloth	Rinse with water	High pressure water, steam or spray
Clean room	Yes	Yes. With light cleaning detergent. See Additional cleaning instructions for Clean Room robots on page 98 .	No	No

Wiping with cloth

Additional cleaning instructions for Clean Room robots

ABB robots with protection types *Clean Room* are designed to be cleaned at a low cleaning frequency, before entering the cleanroom environment, after robot commissioning or during cleanroom maintenance.

Wipe-down cleaning method is recommended. Robot surfaces shall be wiped with clean and low particle emission cleanroom cloth which is soaked in 70% ethanol

Use the following procedure to clean Clean Room robots:

- 1 Before cleaning, use the lint free cloth to remove dirt, debris or any other contaminant from the to-be cleaned surfaces.
 - Make sure no visible residues left.
 - Never apply hard forces on or rub against the robot surfaces to remove dirt or debris; otherwise, protective paint layers may be damaged.
- 2 Wet a clean cloth with the cleaning detergent and then wipe the robot painting surfaces.
 - Make sure no cleaning agents are sprayed onto robot surfaces or into the robot structure.
 - Wipe from the surface center to edge and always in the same direction.
- 3 Wait a few minutes for detergent volatilization.
 - Make sure no residue of cleaning agents left on the robot surfaces after wipe down cleaning.

Cables

Movable cables need to be able to move freely:

- Remove waste material, such as sand, dust and chips, if it prevents cable movement.
- Clean the cables if they have a crusty surface, for example from dry release agents.

4.5 Inspection activities

4.5.1 Inspecting the information labels

Location of labels

These figures show the location of the information labels to be inspected. The symbols are described in section [Safety symbols on manipulator labels on page 19](#).

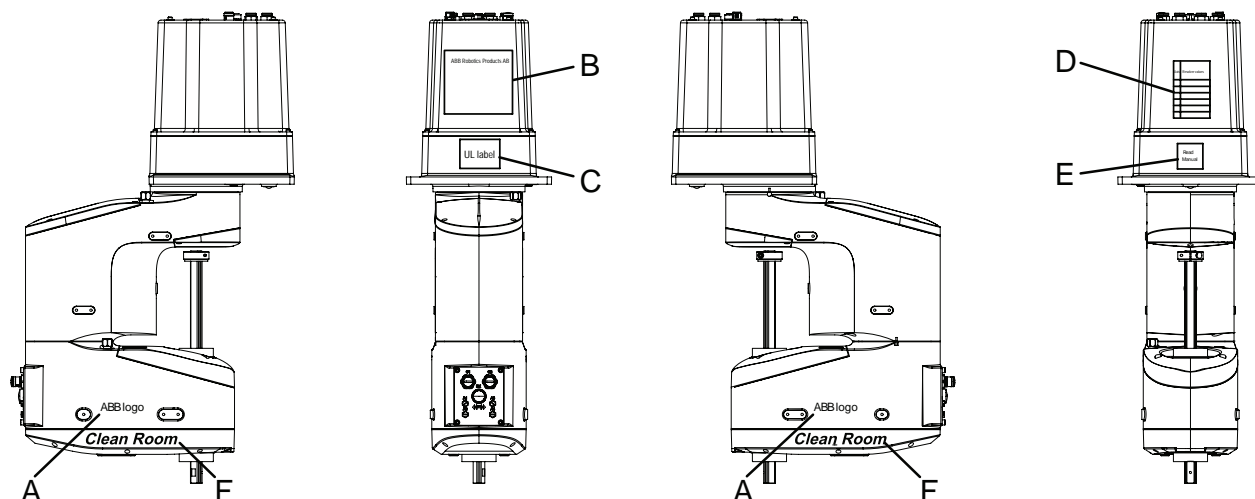

xx190000072

A	ABB logo
B	Rating label
C	UL label
D	Calibration label
E	Read manual and caution
F	Clean Room label ⁱ

ⁱ Only available for Clean Room robots.

Required tools and equipment

Visual inspection, no tools are required.

Inspecting, labels

	Action	Note
1	 DANGER Turn off all: <ul style="list-style-type: none"> • electric power supply • hydraulic pressure supply • air pressure supply to the robot, before entering the safeguarded space.	
2	Inspect the labels, located as shown in the figures.	

Continues on next page

4 Maintenance

4.5.1 Inspecting the information labels

Continued

	Action	Note
3	Replace any missing or damaged labels.	Article numbers for the labels and plate set is specified in Spare parts on page 843 .

4.5.2 Inspecting the robot cabling

Introduction



CAUTION

For robots with protection type Clean Room

Always read the specific instructions before doing any repair work, see [Cut the paint or surface on the robot before replacing parts on page 118](#)

Required tools and equipment

Visual inspection, no tools are required.

Other tools and procedures may be required if the spare part needs to be replaced. These are specified in the replacement procedure.

Inspection, robot cabling

Use this procedure to inspect the robot cabling.

	Action	Note
1	 DANGER Turn off all: <ul style="list-style-type: none"> • electric power supply to the robot • hydraulic pressure supply to the robot • air pressure supply to the robot Before entering the robot working area.	
2	Visually inspect: <ul style="list-style-type: none"> • the control cabling between the robot and control cabinet Look for abrasions, cuts or crush damage.	
3	Replace the cabling if wear or damage is detected.	

4 Maintenance

4.5.3 Inspecting the ball screw spline unit

4.5.3 Inspecting the ball screw spline unit

Introduction



CAUTION

Always read the specific instructions if the robot has protection type Clean Room, before doing any repair work, see [Cut the paint or surface on the robot before replacing parts on page 118](#)

Location of ball screw spline unit

The ball screw spline unit is located as shown in the figure.

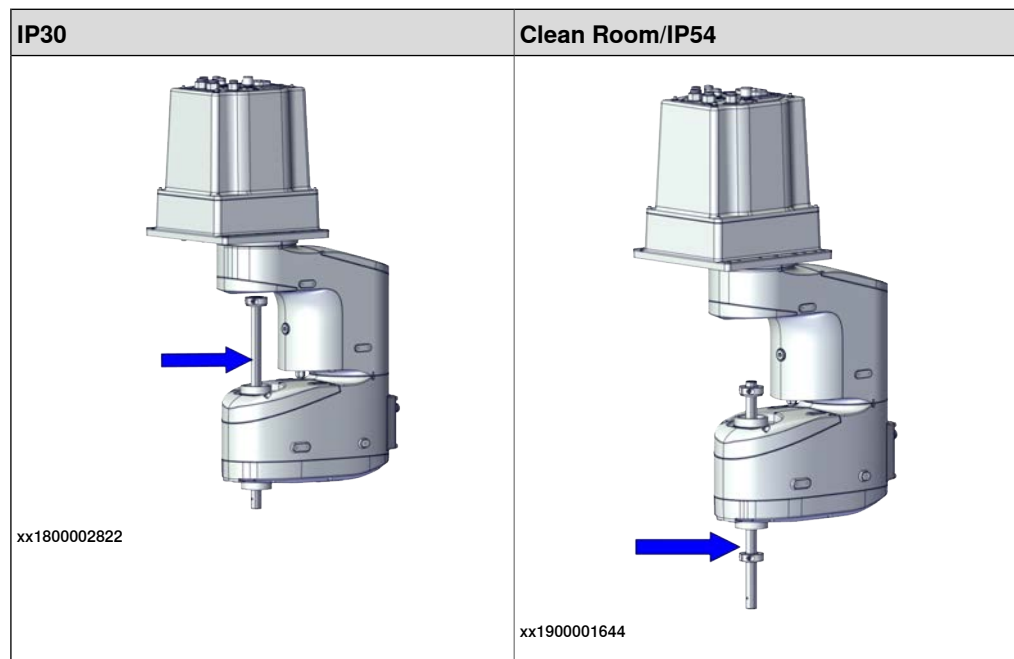

CAUTION

For the robots with protection type Clean Room and protection class IP54, the ball screw spline unit is inside the bellows. If needed, remove the bellows to inspect the ball screw spline unit.

For details about how to remove the bellows, see [Replacing the bellows on page 403](#)

Required spare parts



Note

The spare part numbers that are listed in the table can be out of date. See the latest spare parts of the IRB 910INV via myABB Business Portal, www.abb.com/myABB.

Continues on next page

Spare part	Article number	Note
Ball screw	3HAC061865-001	BNS1616A+330LC5 Used for IRB 910INV-3/0.35
Ball screw	3HAC063635-001	BNS2020A, Short Used for IRB 910INV-6/0.55

Required tools and equipment

Spare part	Article number	Note
Standard toolkit	-	Content is defined in section Standard toolkit on page 840 .
24 VDC power supply	-	Used to release the motor brakes.

Inspecting, ball screw spline unit





Note

For robots with protection type Clean Room

For robots with protection class IP54

First remove the upper bellow and lower bellow according to [Removing the casting cover of the outer arm with the bellow on page 380](#) and [Removing the cover of the outer arm with the bellow on page 392](#).

Then, use this procedure to inspect the ball screw spline unit.

	Action	Note
1	Turn on the electric power supply to the robot. If the robot is not connected to the controller, power must be supplied to the connector R1.MP according to the section Supplying power to connector R1.MP on page 67 .	
2	 DANGER When releasing the holding brakes, the robot axes may move very quickly and sometimes in unexpected ways! Make sure the payload is disassembled or tooling is properly supported; otherwise, fast downward movements of axis 3 may cause severe hits.	
3	Release the holding brake by pressing the button on the internal brake release unit.	 xx1800002816
4	Move the outer arm to a position where the axis 3 can be moved in full stroke.	

Continues on next page

4 Maintenance

4.5.3 Inspecting the ball screw spline unit

Continued

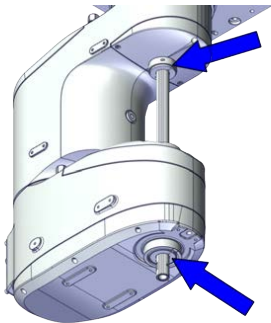
	Action	Note
5	Press the brake release button and move the shaft to its upper and lower limits manually.	 <p>xx1800002816</p>
6	Visually inspect: <ul style="list-style-type: none"> • the stop blocks on the ball screw spline unit • the shaft of the ball screw spline unit Look for abrasions, cuts or crush damages on the spline, and grease amount on the shaft.	 <p>xx1800002820</p>
7	Apply grease to the shaft if it is not enough.	See Lubricating the ball screw spline unit on page 114 .
8	Replace the ball screw spline unit if wear or damage is detected.	See Replacing the ball screw on page 464 .

4.5.4 Inspecting axis-3 mechanical stops

Introduction



CAUTION

Always read the specific instructions if the robot has protection type Clean Room, before doing any repair work, see [Cut the paint or surface on the robot before replacing parts on page 118](#)

Location of axis-3 mechanical stops

The mechanical stops on axis 3 is located as shown in the figures.

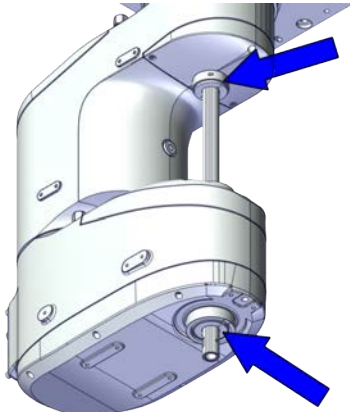
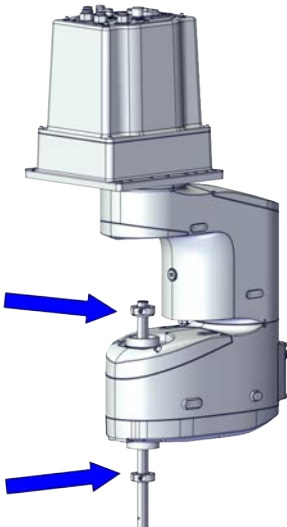
IP30	Clean Room/IP54
 <p data-bbox="448 1205 560 1223">xx1800002820</p>	 <p data-bbox="951 1330 1062 1348">xx1900001643</p>



CAUTION

For the robots with protection type Clean Room and protection class IP54, the mechanical stops are inside the bellows. If needed, remove the bellows to inspect the ball screw spline unit.

For the details on removing the bellows, refer to [Replacing the bellows](#).

Required spare parts



Note

The spare part numbers that are listed in the table can be out of date. See the latest spare parts of the IRB 910INV via myABB Business Portal, www.abb.com/myABB.

Spare part	Article number	Note
Mechanical-Stop top, D16	3HAC073060-001	Used for IRB 910INV-3/0.35

Continues on next page

4 Maintenance

4.5.4 Inspecting axis-3 mechanical stops

Continued

Spare part	Article number	Note
Mechanical-Stop top, D20	3HAC073068-001	Used for IRB 910INV-6/0.55
Mechanical-Stop bottom, D16	3HAC073061-001	Used for IRB 910INV-3/0.35
Mechanical-Stop bottom, D20	3HAC073069-001	Used for IRB 910INV-6/0.55

Required tools and equipment

Visual inspection, no tools are required.

Other tools and procedures may be required if the spare part needs to be replaced. These are specified in the replacement procedure.

Inspecting, axis-3 mechanical stops



Note



For robots with protection type Clean Room

For robots with protection class IP54



First remove the upper bellow and lower bellow according to [Removing the casting cover of the outer arm with the bellow on page 380](#) and [Removing the cover of the outer arm with the bellow on page 392](#).

Then, use this procedure to inspect the ball screw spline unit.

Use this procedure to inspect mechanical stops on axes 1 and 2.

	Action	Information
1	 DANGER Turn off all: <ul style="list-style-type: none">• electric power supply• hydraulic pressure supply• air pressure supply to the robot, before entering the robot working area.	
2	 CAUTION For robots with protection type Clean Room Always cut the paint with a knife and grind the paint edge when disassembling parts of the robot! See Cut the paint or surface on the robot before replacing parts on page 118 .	

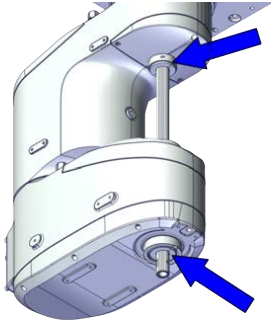
Continues on next page

	Action	Information
3	Inspect the mechanical stops.	 <p>xx1800002820</p>
4	Replace if any mechanical stop is: <ul style="list-style-type: none"> • bent • loose • damaged.  Note The expected life of gearboxes can be reduced as a result of collisions with the mechanical stop.	

4 Maintenance

4.5.5 Inspecting the bellows

4.5.5 Inspecting the bellows

Introduction



CAUTION

Always read the specific instructions if the robot has protection type Clean Room, before doing any repair work, see [Cut the paint or surface on the robot before replacing parts on page 118](#)

Location of bellows

The bellows are located as shown in the figures.

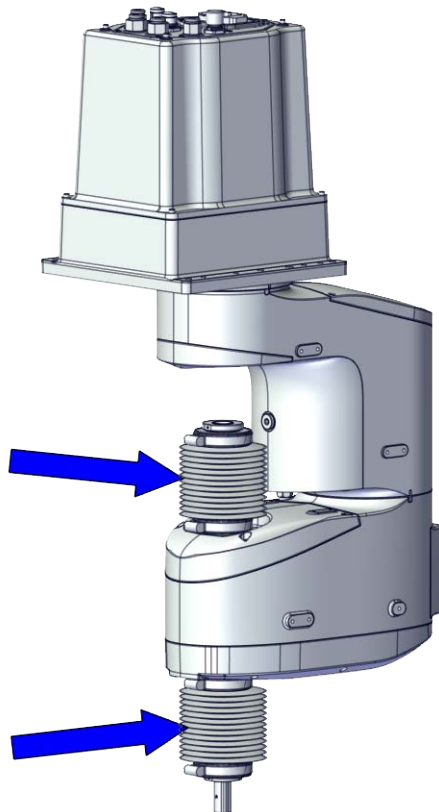

xx1900001546

Required spare parts



Note

The spare part numbers that are listed in the table can be out of date. See the latest spare parts of the IRB 910INV via myABB Business Portal, www.abb.com/myABB.

Spare part	Article number	Note
Bellow, 350 mm	3HAC062062-001	

Continues on next page

Spare part	Article number	Note
Bellow, 550 mm	3HAC066917-001	
Bellow Gasket, 350 mm	3HAC071546-001	Replace if damaged.
Bellow Gasket, 550 mm	3HAC071547-001	Replace if damaged.
Cover, BS16, 350 mm	3HAC066654-001	Replace if damaged.
Cover, BS20, 550 mm	3HAC066915-001	Replace if damaged.
Cover Lower, BS16, 350 mm	3HAC067936-001	Replace if damaged.
Cover Lower, BS20, 550 mm	3HAC067937-001	Replace if damaged.
Extension shaft, BS16, 350 mm	3HAC073236-001	Replace if damaged.
Extension shaft, BS20, 550 mm	3HAC073239-001	Replace if damaged.
Shaft, BS16, 350 mm	3HAC066656-001	Replace if damaged.
Shaft, BS20, 550 mm	3HAC066916-001	Replace if damaged.
O-ring, 350 mm	3HAB3772-198	Replace if damaged.
O-ring, 550 mm	3HAC061327-023	Replace if damaged.
Housing, BS16, 350 mm	3HAC073237-001	Replace if damaged.
Housing, BS20, 550 mm	3HAC073240-001	Replace if damaged.
Housing Lower, BS16, 350 mm	3HAC073238-001	Replace if damaged.
Housing Lower, BS20, 550 mm	3HAC073241-001	Replace if damaged.

Required tools and equipment

Visual inspection, no tools are required.

Other tools and procedures may be required if the spare part needs to be replaced. These are specified in the replacement procedure.

Spare part	Article number	Note
Standard toolkit	-	Content is defined in section Standard toolkit on page 840 .

Inspecting, bellows

Use this procedure to inspect bellows on the ball screw unit.

	Action	Information
1	 DANGER Turn off all: <ul style="list-style-type: none"> • electric power supply • hydraulic pressure supply • air pressure supply to the robot, before entering the robot working area.	

Continues on next page

4 Maintenance

4.5.5 Inspecting the bellows

Continued

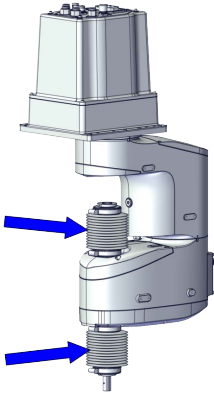
	Action	Information
2	Inspect the bellows.	 <p>xx1900001546</p>
3	Replace if any bellow is: <ul style="list-style-type: none">• aged• loose• damaged.	
4	Check the clamps torque.	Tightening torque for the clamps: 0.6 Nm \pm 10%
5	Adjust the clamps if needed.	

4.5.6 Inspecting timing belts

Introduction



CAUTION

Always read the section "General procedures" before doing any repair work.
Cut the paint or surface on the robot before replacing parts on page 118.

Location of timing belts

The timing belts are located as shown in the figures.

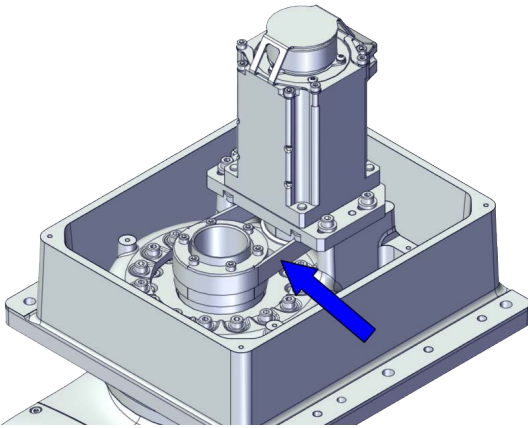
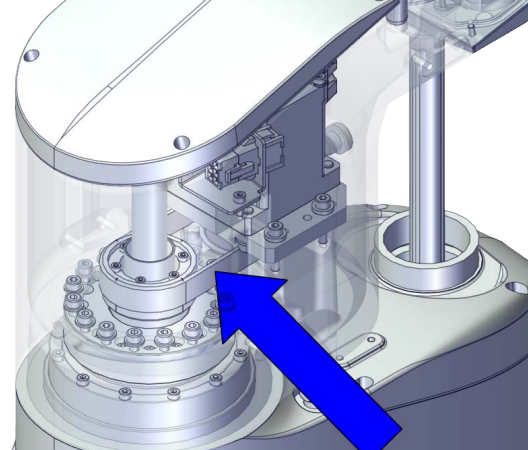
Axis	Location
1	 <p>xx1800002853</p>
2	 <p>xx1800002856</p>

Continues on next page

4 Maintenance

4.5.6 Inspecting timing belts

Continued

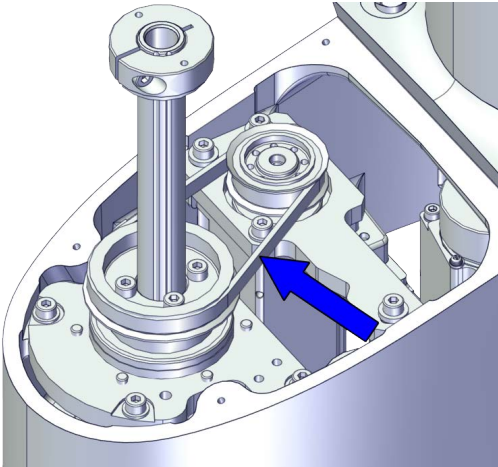
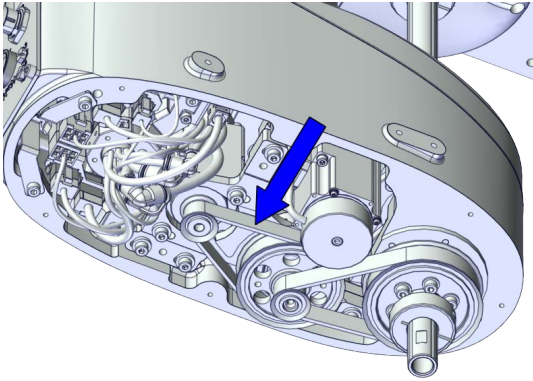
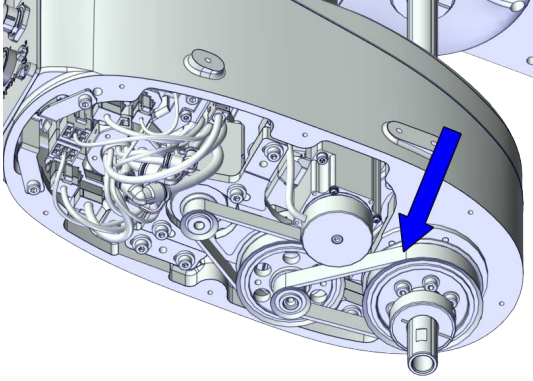
Axis	Location
3	 <p>xx1800003400</p>
4	 <p>xx1800003401</p>
4-2	 <p>xx1800003402</p>

Required tools and equipment

Equipment	Note
Standard toolkit	The content is defined in the section Standard toolkit on page 840 .

Continues on next page

Equipment	Note
Other tools and procedures may be required if the spare part needs to be replaced. These are specified in the replacement procedure.	

Timing belt tension

The table describes the timing belt tension.

Axis	Force		Frequency	
	Used timing belt	New timing belt	Used timing belt	New timing belt
Axis 1	70-80N	100-110N	250-305Hz	296-378Hz
Axis 2	45-51N	65-71N	193-236Hz	229-293Hz
Axis 3	22-26N	32-36N	190-232Hz	225-287Hz
Axis 4	27-31N	38-42N	178-217Hz	210-268Hz
Axis 4-2	84-96N	120-132N	257-314Hz	304-389Hz

Inspecting timing belts

Use this procedure to inspect timing belts.

	Action	Information
1	 DANGER Turn off all: <ul style="list-style-type: none"> • electric power supply • hydraulic pressure supply • air pressure supply to the robot, before entering the robot working area.	
2	Gain access to each <i>timing belt</i> by removing the cover.	
3	Check the timing belts for damage or wear.	
4	Check the <i>timing belt pulleys</i> for damage.	
5	If any damage or wear is detected, the part must be replaced!	
6	Use a sonic tension meter to measure the timing belt tension. Adjust the belt tension if needed!	See Timing belt tension on page 113 .

4 Maintenance

4.6.1 Lubricating the ball screw spline unit

4.6 Lubrication activities

4.6.1 Lubricating the ball screw spline unit

Location of the ball screw spline unit

The ball screw spline unit is located as shown in the figure.

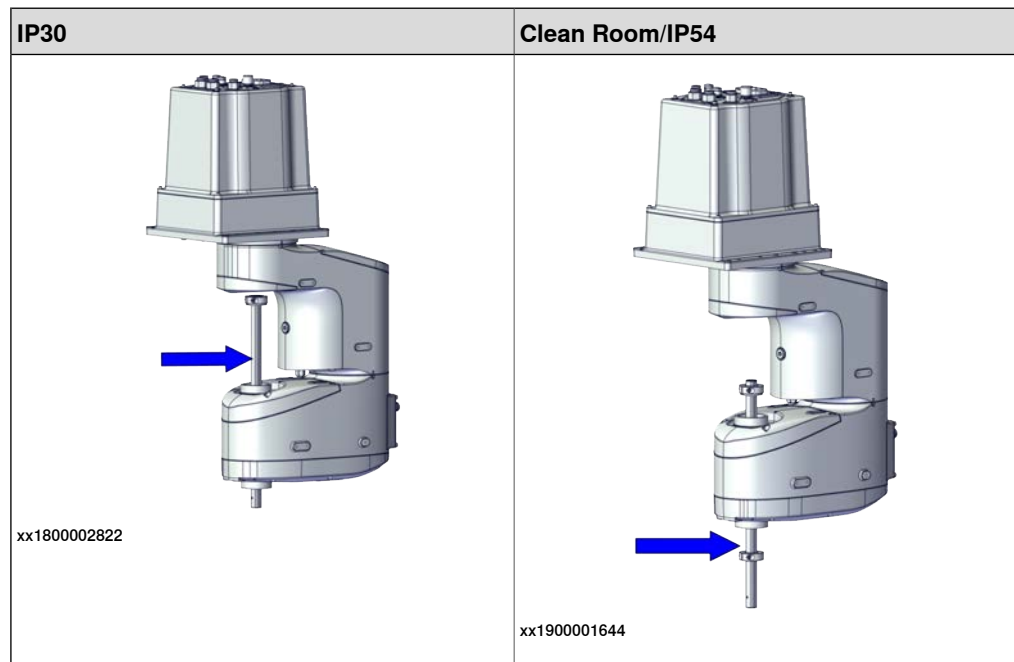

CAUTION

For the robots with protection type Clean Room and protection class IP54, the ball screw spline unit is inside the bellows. If needed, remove the bellows to inspect the ball screw spline unit.

For details about how to remove the bellows, see [Replacing the bellows](#).

Required tools and equipment

Equipment	Article number	Note
24 VDC power supply	-	Used to release the motor brakes.

Required consumables

Consumable	Article number	Note
Grease	-	THK AFA Used to lubricate the ball screw spline shaft.

Continues on next page

Lubricating the ball screw spline unit

**Note**

For robots with protection type Clean Room

For robots with protection class IP54

First remove the upper bellow and lower bellow according to [Removing the casting cover of the outer arm with the bellow on page 380](#) and [Removing the cover of the outer arm with the bellow on page 392](#).

Then, use this procedure to inspect the ball screw spline unit.

**Note**

Cover the end effector and peripheral equipment in case the grease drips, before lubricating the ball screw spline unit.

	Action	Note
1	Turn on the electric power supply to the robot. If the robot is not connected to the controller, power must be supplied to the connector R1.MP according to the section Supplying power to connector R1.MP on page 67 .	
2	 DANGER When releasing the holding brakes, the robot axes may move very quickly and sometimes in unexpected ways! Make sure the payload is disassembled or tooling is properly supported; otherwise, fast downward movements of axis 3 may cause severe hits.	
3	Release the holding brake by pressing the button on the internal brake release unit.	
4	Move the outer arm to a position where the axis 3 can be moved in full stroke.	
5	Move the shaft manually to its upper limit while pressing the brake release button.	
6	Wipe off old grease from the shaft.	
7	Apply new grease and fill the grooves. Wipe off excessive grease.	
8	Move the shaft manually to its lower limit while pressing the brake release button.	
9	Wipe off old grease from the shaft.	
10	Apply new grease and fill the grooves. Wipe off excessive grease.	
11	Move the shaft up and down several times while pressing the brake release button to smooth out the grease on the shaft. Wipe off excessive grease.	

4 Maintenance

4.7 Replacement/changing activities

4.7 Replacement/changing activities

Replacing the battery pack

Replacing the battery pack is accessible after removing the SMB from the base, see [Replacing the SMB unit and battery unit on page 214](#).

5 Repair

5.1 Introduction

Structure of this chapter

This chapter describes repair activities for the IRB 910INV. Each procedure contains the information required to perform the activity, for example spare parts numbers, required special tools, and materials.



WARNING

Repair activities not described in this chapter must only be carried out by ABB.

Report replaced units



Note

When replacing a part on the IRB 910INV, report to your local ABB the serial number, the article number, and the revision of both the replaced unit and the replacement unit.

This is particularly important for safety equipment to maintain the safety integrity of the installation.

Safety information

Make sure to read through the chapter [Safety on page 15](#) before commencing any service work.



Note

The robot should be secured with the transportation brackets during removing from/refitting to the foundation.



Note

If the IRB 910INV is connected to power, always make sure that the IRB 910INV is connected to protective earth and a residual current device (RCD) before starting any repair work.

For more information see:

- *Product manual - OmniCore C30*
- *Product manual - OmniCore C90XT*
- *Product manual - OmniCore E10*

5 Repair

5.2.1 Cut the paint or surface on the robot before replacing parts

5.2 General procedures

5.2.1 Cut the paint or surface on the robot before replacing parts

General

Follow the procedures in this section whenever breaking the paint of the robot during replacement of parts.

For robots with protection type Clean Room

When replacing parts on the robot, it is important to make sure that after the replacement, no particles will be emitted from the joint between the structure and the new part, and that the easy cleaned surface is retained.

Required equipment

Equipment	Spare parts	Note
Sealing compound	3HAC026759-001	Sikaflex 521 FC. Color white.
Tooling pin		Width 6-9 mm, made of wood.
Cleaning agent		Ethanol
Knife		
Lint free cloth		
Touch up paint Clean Room/Hygienic	3HAC036639-001	White
Touch up paint Standard/Foundry Plus	3HAC067974-001	Graphite White

Removing

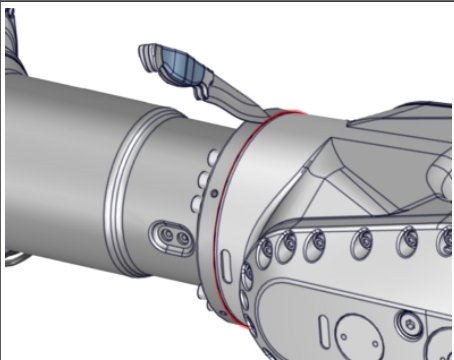
Action	Description
1 Cut the paint with a knife in the joint between the part that will be removed and the structure, to avoid that the paint cracks.	 xx230000950
2 Carefully grind the paint edge that is left on the structure to a smooth surface.	

Refitting





Note

Refitting is required only for robots with protection type Clean Room.

Continues on next page

5.2.1 Cut the paint or surface on the robot before replacing parts

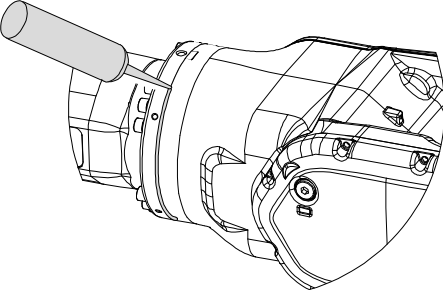
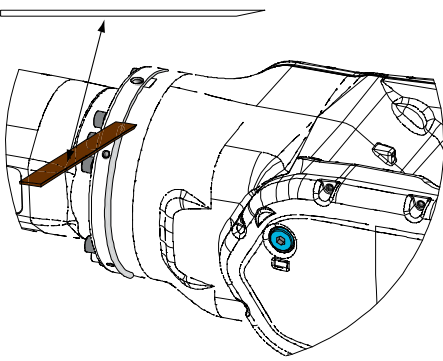
Continued

	Action	Description
1	Before the parts are refitted, clean the joint so that it is free from oil and grease.	Use ethanol on a lint free cloth.
2	Place the tooling pin in hot water.	
3	Seal all refitted joints with sealing compound.	 <p data-bbox="991 725 1098 745">xx0900000122</p>
4	Use the tooling pin to even out the surface of the sealing compound.	 <p data-bbox="991 1167 1098 1187">xx0900000125</p>
5	For robots with protection type Clean Room Wait 10 minutes.	For robots with protection type Clean Room Sikaflex 521FC skin dry time (10 minutes).
6	Use Touch up paint Clean Room/Hygienic, white to paint any damaged surfaces.  Note Always read the instruction in the product data sheet in the paint repair kit for Clean Room/Hygienic.	3HAC036639-001
 Note After all repair work, wipe the robot free from particles with spirit on a lint free cloth.		

5 Repair

5.3.1 Replacing the base harness

5.3 Cable harness

5.3.1 Replacing the base harness

Location of the base harness

The base harness is located as shown in the figure.

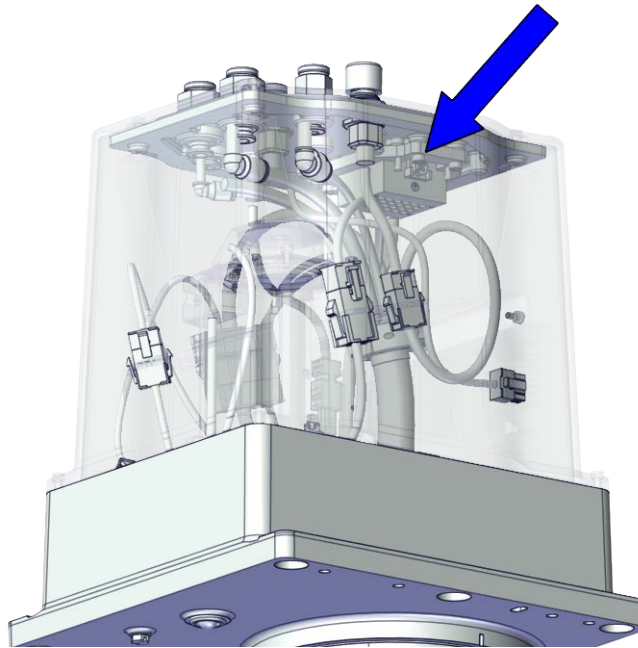

xx180002824

Required spare parts



Note

The spare part numbers that are listed in the table can be out of date. See the latest spare parts of the IRB 910INV via myABB Business Portal, www.abb.com/myABB.

Spare part	Article number	Note
Base harness, B	3HAC073378-001	
Base harness, B+C1+A	3HAC073379-001	
Base harness, B+C1+C2+A	3HAC073380-001	
Base cover, casting	3HAC073045-001	
SMB unit	3HAC063968-001	
Plug, Standard	3HAC071966-001	Used with standard protection class IP30 and IP54.
Plug, Clean Room	3HAC072418-001	Used with protection type Clean Room.
Air Connector, Clean Room	3HAC072417-001	Used with protection type Clean Room.

Continues on next page

Spare part	Article number	Note
O-ring, Harting connector	3HAB3772-19	

Required tools and equipment

Equipment	Article number	Note
Standard toolkit	-	Content is defined in section Standard toolkit on page 840 .
Calibration tool box, Axis Calibration	3HAC074119-001	Delivered as a set of calibration tools. Required if Axis Calibration is the valid calibration method for the robot. ⁱ

ⁱ The robot is calibrated by either manual calibration or Axis Calibration at ABB factory before delivery. Always use the same calibration method as used at the factory.
Information about valid calibration method is found on the calibration label or in the calibration menu on the FlexPendant.
If no data is found related to standard calibration, manual calibration is used as default.

Required consumables

Consumable	Article number	Note
Cable straps	-	
Grease	3HAC029132-001	FM 222 Used to lubricate the cable harness.

Deciding calibration routine

Decide which calibration routine to be used, based on the information in the table. Depending on which routine is chosen, action might be required prior to beginning the repair work of the robot, see the table.

	Action	Note
1	Decide which calibration routine to use for calibrating the robot. <ul style="list-style-type: none"> Reference calibration. External cable packages (DressPack) and tools can stay fitted on the robot. Fine calibration. All external cable packages (DressPack) and tools must be removed from the robot. 	
	<p>If the robot is to be calibrated with reference calibration:</p> <p>Find previous reference values for the axis or create new reference values. These values are to be used after the repair procedure is completed, for calibration of the robot.</p> <p>If no previous reference values exist, and no new reference values can be created, then reference calibration is not possible.</p>	<p>Follow the instructions given in the reference calibration routine on the FlexPendant to create reference values.</p> <p>Creating new values requires possibility to move the robot.</p> <p>Read more about reference calibration for Axis Calibration in Reference calibration routine on page 798.</p>

Continues on next page

5 Repair

5.3.1 Replacing the base harness



Continued

Action	Note
<p>If the robot is to be calibrated with fine calibration: Remove all external cable packages (DressPack) and tools from the robot.</p>	

Removing the base harness

Use these procedures to remove the base harness.

Preparations before removing the base harness

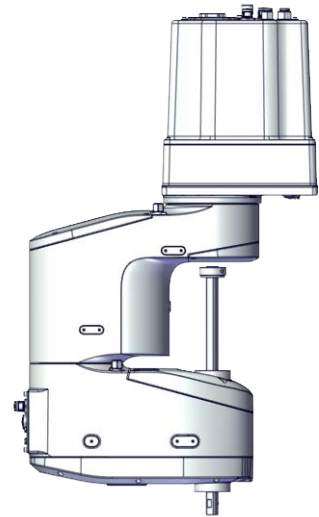

Action	Note
1	Decide which calibration routine to use, and take actions accordingly prior to beginning the repair procedure.
2	Jog all axes to zero position.
3	<p> DANGER</p> <p>Turn off all:</p> <ul style="list-style-type: none"> • electric power supply • hydraulic pressure supply • air pressure supply <p>to the robot, before entering the safeguarded space.</p>
4	<p> CAUTION</p> <p>For robots with protection type Clean Room Always cut the paint with a knife and grind the paint edge when disassembling parts of the robot! See <i>Cut the paint or surface on the robot before replacing parts on page 118.</i></p>



xx1800002825

Continues on next page

Removing the base cover

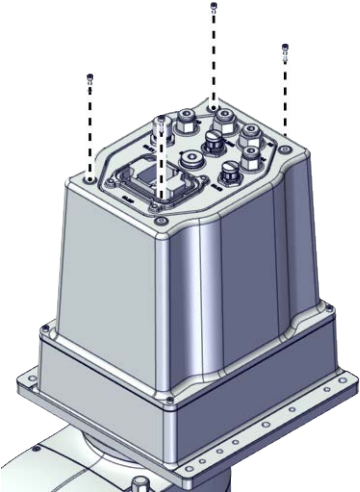
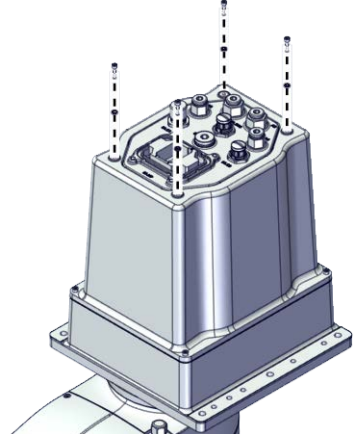
	Action	Note
1	 <p>DANGER</p> <p>Make sure that all supplies for electrical power, hydraulic pressure, and air pressure are turned off.</p>	
2	 <p>CAUTION</p> <p>For robots with protection type Clean Room Always cut the paint with a knife and grind the paint edge when disassembling parts of the robot! See <i>Cut the paint or surface on the robot before replacing parts on page 118.</i></p>	
3	<p>Remove the screws on the base cover to the base harness.</p>  <p>Note</p> <p>For robots with protection class IP54 (option 3350-540) For robots with protection type Clean Room (option 3351-1) Remove the extra sealing washers on the base cover to the base harness.</p>	<p>For robots with protection class IP30 (option 3350-300)</p>  <p>xx1800002826</p> <p>For robots with protection class IP54 (option 3350-540) For robots with protection type Clean Room (option 3351-1)</p>  <p>xx1900001634</p>

Continues on next page



5 Repair

5.3.1 Replacing the base harness

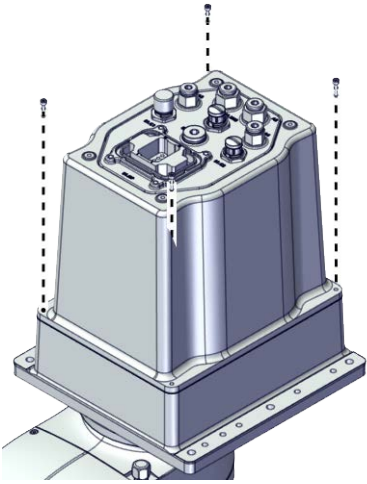
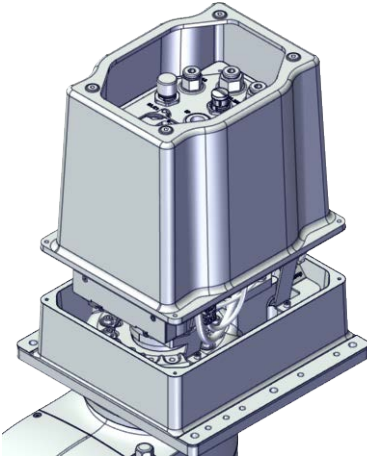

Continued

	Action	Note
4	Remove the screws on the base cover to the base.	 <p>xx1800002827</p>
5	Take the base cover out.	 <p>xx1800002828</p>

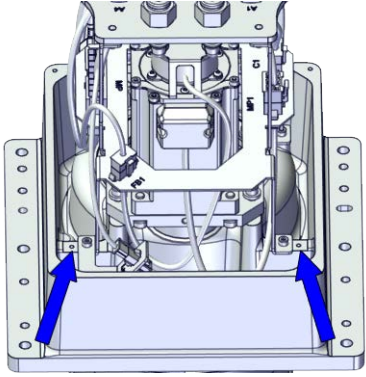

Disconnecting the connectors on the base harness

	Action	Note
1	 <p>DANGER</p> <p>Make sure that all supplies for electrical power, hydraulic pressure, and air pressure are turned off.</p>	
2	 <p>CAUTION</p> <p>For robots with protection type Clean Room Always cut the paint with a knife and grind the paint edge when disassembling parts of the robot! See Cut the paint or surface on the robot before replacing parts on page 118.</p>	

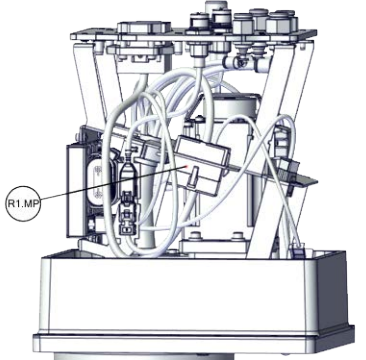
Continues on next page

	Action	Note
3	Remove the three grounding cables from the bracket by unscrew the screws.	 <p>xx1900000062</p>
4	Disconnect the connector. <ul style="list-style-type: none"> • R1.MP  Tip Take photos of the connector and cable position before disconnecting them, to have as a reference when reconnecting.	 <p>xx1800002829</p>

Disconnecting the SMB cabling

	Action	Note
1	 DANGER Make sure that all supplies for electrical power, hydraulic pressure, and air pressure are turned off.	
2	 ELECTROSTATIC DISCHARGE (ESD) The unit is sensitive to ESD. Before handling the unit read the safety information in section The unit is sensitive to ESD on page 45 .	
3	 CAUTION For robots with protection type Clean Room Always cut the paint with a knife and grind the paint edge when disassembling parts of the robot! See Cut the paint or surface on the robot before replacing parts on page 118 .	

Continues on next page



5 Repair

5.3.1 Replacing the base harness

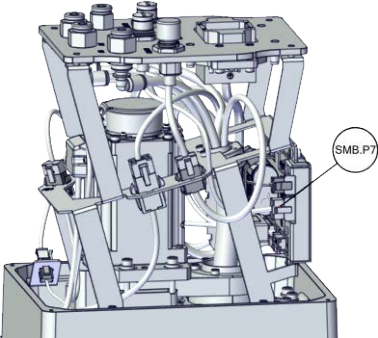



Continued

	Action	Note
4	<p>Disconnect the connectors.</p> <ul style="list-style-type: none"> • SMB.P7 • SMB.J1 (Only when the internal harness) <p> Tip</p> <p>Take photos of the connector and cable position before disconnecting them, to have as a reference when reconnecting.</p>	 <p>xx1800002833</p>

Disconnecting the air hoses, C1 cabling and C2 cabling (if equipped)

	Action	Note
1	<p> DANGER</p> <p>Make sure that all supplies for electrical power, hydraulic pressure, and air pressure are turned off.</p>	
2	<p> CAUTION</p> <p>For robots with protection type Clean Room</p> <p>Always cut the paint with a knife and grind the paint edge when disassembling parts of the robot! See Cut the paint or surface on the robot before replacing parts on page 118.</p>	

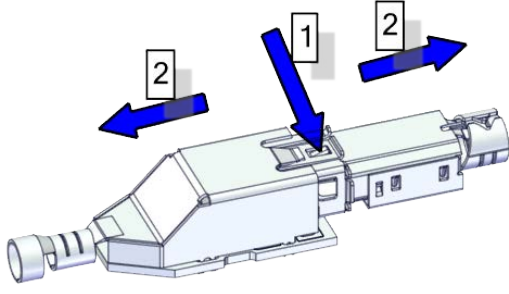
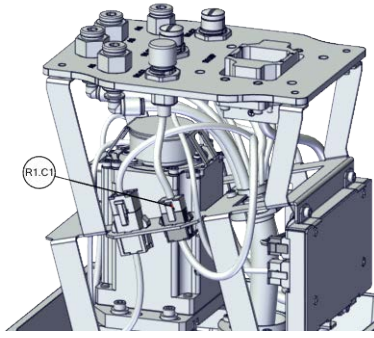
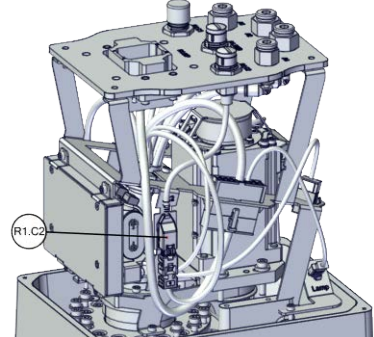
Continues on next page

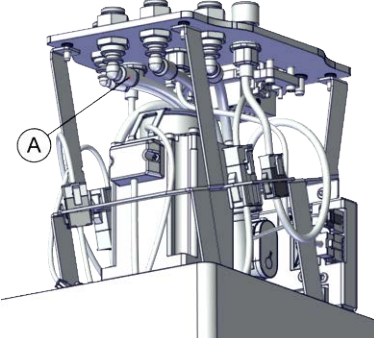
	Action	Note		
3	<p>Cut the cable straps and disconnect the connectors.</p> <ul style="list-style-type: none"> • R1.C1 • R1.C2 <p> Tip</p> <p>Take photos of the connector and cable position before disconnecting them, to have as a reference when reconnecting.</p> <p> Tip</p> <p>The connector clip has to be pressed (1) and pushed forward (2) to separate the R1.C2 (for C2 cabling).</p>  <p>xx1800002943</p>	 <p>xx1800002831</p>  <p>xx1800002832</p>		
4	<p>Disconnect the air hoses from the L-shaped connectors.</p> <p> Note</p> <p>Make sure that the air hoses are not bent or broken when you disconnect them.</p>	 <p>xx1800002830</p> <table border="1" data-bbox="1061 1601 1436 1657"> <tr> <td data-bbox="1061 1601 1117 1657">A</td> <td data-bbox="1117 1601 1436 1657">Air hoses</td> </tr> </table>	A	Air hoses
A	Air hoses			

Removing the base harness

	Action	Note
1	<p> DANGER</p> <p>Make sure that all supplies for electrical power, hydraulic pressure, and air pressure are turned off.</p>	

Continues on next page

5 Repair

5.3.1 Replacing the base harness

Continued

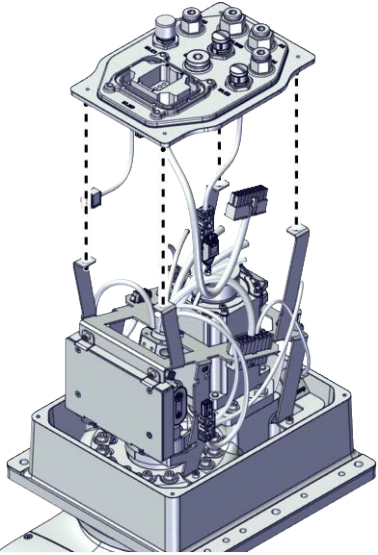
	Action	Note
2	 CAUTION For robots with protection type Clean Room Always cut the paint with a knife and grind the paint edge when disassembling parts of the robot! See Cut the paint or surface on the robot before replacing parts on page 118 .	
3	Remove the base harness from the bracket.	 <small>xx1800002834</small>

Refitting the base harness

Use these procedures to refit the base harness.



Refitting the base harness

	Action	Note
1	For robots with protection type Clean Room: Clean the joints that have been opened and wipe the parts free from particles with spirit on a lint free. See Cut the paint or surface on the robot before replacing parts on page 118  Note After all repair work, wipe the Clean Room robot free from particles with spirit on a lint free cloth.	

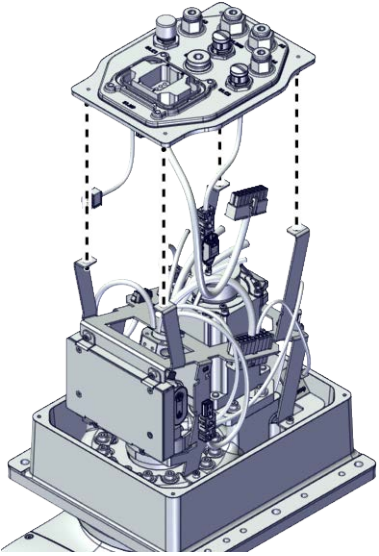
Continues on next page

	Action	Note
2	Refit the base harness to the bracket.	 <p>xx1800002834</p>

Reconnecting the air hoses, C1 cabling and C2 cabling (if equipped)

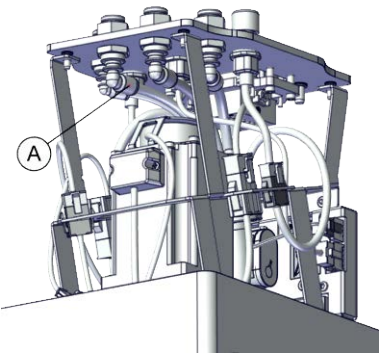

	Action	Note		
1	<p>For robots with protection type Clean Room: Clean the joints that have been opened and wipe the parts free from particles with spirit on a lint free. See Cut the paint or surface on the robot before replacing parts on page 118</p> <p> Note</p> <p>After all repair work, wipe the Clean Room robot free from particles with spirit on a lint free cloth.</p>			
2	<p>Reconnect the air hoses in a cross pattern to the L-shaped connectors on the base harness.</p> <p> Tip</p> <p>See the number markings on the air hoses for help to find the corresponding air hoses. The air hoses with the same number connect to the same L-shaped connector.</p> <p> Note</p> <p>Make sure that the air hoses are not bent or broken when you disconnect them.</p>	 <p>xx1800002830</p> <table border="1" data-bbox="1061 1765 1441 1816"> <tr> <td data-bbox="1061 1765 1117 1816">A</td> <td data-bbox="1117 1765 1441 1816">Air hoses</td> </tr> </table>	A	Air hoses
A	Air hoses			

Continues on next page

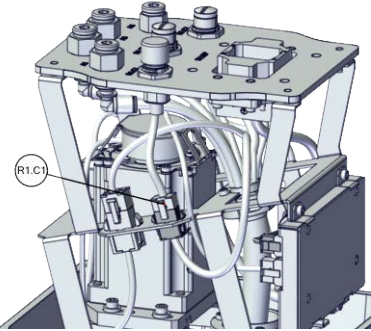
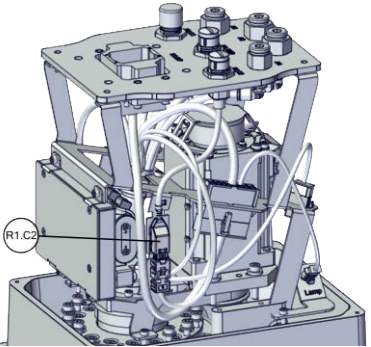

5 Repair

5.3.1 Replacing the base harness



Continued

	Action	Note
3	<p>Reconnect the connectors.</p> <ul style="list-style-type: none"> • R1.C1 • R1.C2 <p> Tip</p> <p>See the number markings on the connectors for help to find the corresponding connector.</p>	 <p>xx1800002831</p>  <p>xx1800002832</p>
4	<p>Route and secure the cabling with cable straps if needed.</p> <p> CAUTION</p> <p>Correct cable routing is highly important. If the cables are routed and secured incorrectly the cables can be damaged.</p>	

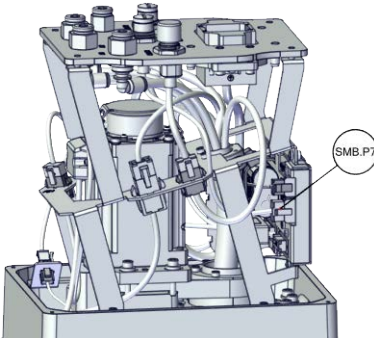

Reconnecting the SMB cabling

	Action	Note
1	<p> ELECTROSTATIC DISCHARGE (ESD)</p> <p>The unit is sensitive to ESD. Before handling the unit read the safety information in section The unit is sensitive to ESD on page 45.</p>	
2	<p>For robots with protection type Clean Room: Clean the joints that have been opened and wipe the parts free from particles with spirit on a lint free. See Cut the paint or surface on the robot before replacing parts on page 118</p> <p> Note</p> <p>After all repair work, wipe the Clean Room robot free from particles with spirit on a lint free cloth.</p>	

Continues on next page

	Action	Note
3	<p>Reconnect the connectors.</p> <ul style="list-style-type: none"> • SMB.P7 • SMB.J1 <p> Tip</p> <p>See the number markings on the connectors for help to find the corresponding connector.</p>	 <p>xx1800002833</p>
4	<p>Route and secure the cabling with cable straps if needed.</p> <p> CAUTION</p> <p>Correct cable routing is highly important. If the cables are routed and secured incorrectly the cables can be damaged.</p>	

Reconnecting the connectors on the base harness

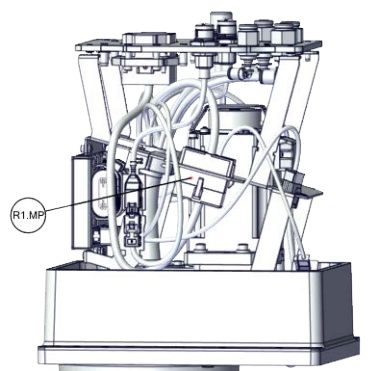

	Action	Note
1	<p>For robots with protection type Clean Room: Clean the joints that have been opened and wipe the parts free from particles with spirit on a lint free. See Cut the paint or surface on the robot before replacing parts on page 118</p> <p> Note</p> <p>After all repair work, wipe the Clean Room robot free from particles with spirit on a lint free cloth.</p>	
2	<p>Reconnect the connector.</p> <ul style="list-style-type: none"> • R1.MP <p> Tip</p> <p>See the number markings on the connectors for help to find the corresponding connector.</p>	 <p>xx1800002829</p>

Continues on next page

5 Repair

5.3.1 Replacing the base harness

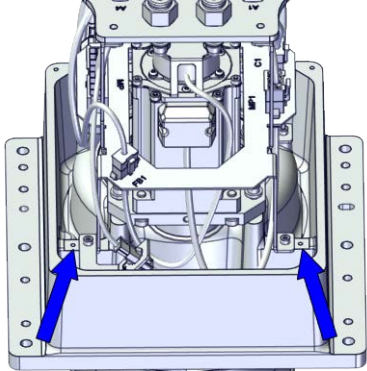

Continued

	Action	Note
3	Secure the three grounding cables to the bracket with the screw.	<p>Screws: Hex socket head cap screw M3x5 12.9 Lafre 2C2B/FC6.9 (2 pcs) Tightening torque: 1.5 Nm \pm10%</p>  <p>xx1900000062</p>
4	<p>Route and secure the cabling with cable straps if needed.</p> <p> CAUTION</p> <p>Correct cable routing is highly important. If the cables are routed and secured incorrectly the cables can be damaged.</p>	

Refitting the base cover

	Action	Note
1	<p>For robots with protection type Clean Room: Clean the joints that have been opened and wipe the parts free from particles with spirit on a lint free. See Cut the paint or surface on the robot before replacing parts on page 118</p> <p> Note</p> <p>After all repair work, wipe the Clean Room robot free from particles with spirit on a lint free cloth.</p>	
2	Apply grease to the internal harness, cover all moving area of the harness.	
3	Apply grease to the covers that have contacting area with the harness.	

Continues on next page

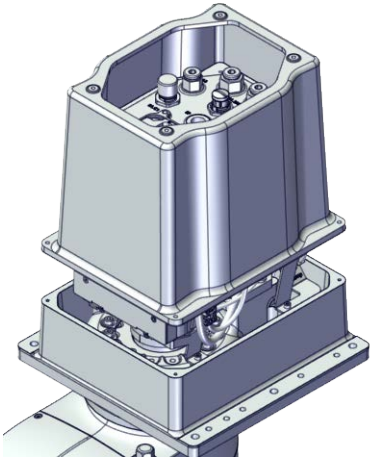
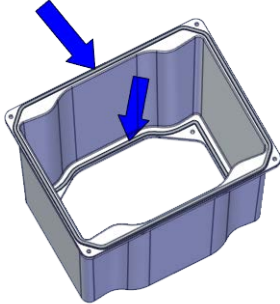
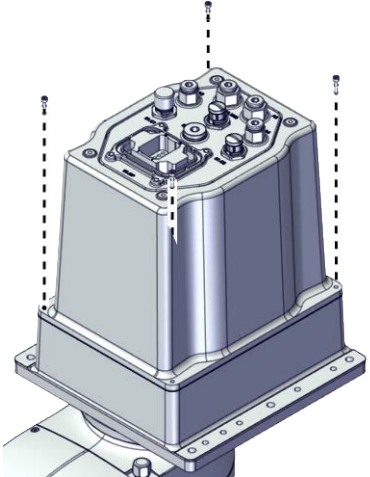
	Action	Note
<p>4</p>	<p>Refit the base cover.</p> <p> Note</p> <p>For robots with protection class IP54 (option 3350-540)</p> <p>For robots with protection type Clean Room (option 3351-1)</p> <p>Check the gasket for the base and the gasket for the base cover before refitting the base cover.</p> <p> Tip</p> <p>Replace the gasket if needed.</p>	 <p>xx1800002828</p> <p>For robots with protection class IP54 (option 3350-540)</p> <p>For robots with protection type Clean Room (option 3351-1)</p>  <p>xx1900001635</p>
<p>5</p>	<p>Secure the base cover to the base with the screws.</p>	<p>Screws: Hex socket head cap screw M3x12 12.9 Lafre 2C2B/FC6.9 (4 pcs)</p> <p>Tightening torque: 1.2 Nm ±10%</p>  <p>xx1800002827</p>

Continues on next page

5 Repair

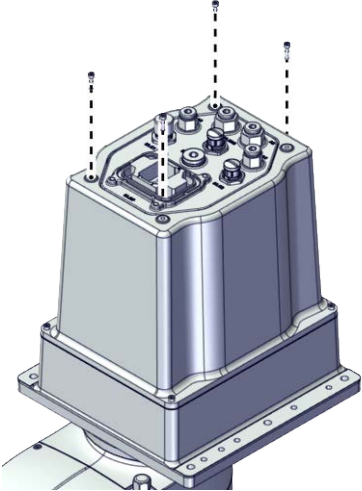
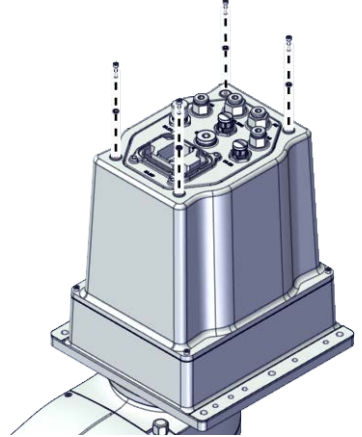

5.3.1 Replacing the base harness

Continued

	Action	Note
6	<p>Secure the base harness to the base cover with the screws.</p> <p> Note</p> <p>For robots with protection class IP54 (option 3350-540)</p> <p>For robots with protection type Clean Room (option 3351-1)</p> <p>Refit the extra sealing washers on the base cover to the base harness.</p>	<p>For robots with protection class IP30 (option 3350-300)</p> <p>Screws: Hex socket head cap screw M3x12 12.9 Lafre 2C2B/FC6.9 (4 pcs)</p> <p>Tightening torque: 1.2 Nm \pm10%</p>  <p>xx1800002826</p> <p>For robots with protection class IP54 (option 3350-540)</p> <p>For robots with protection type Clean Room (option 3351-1)</p> <p>Screws: Hex socket head cap screw M3x12 12.9 Lafre 2C2B/FC6.9 (4 pcs)</p> <p>Washers: Sealing washer M3 (4 pcs)</p> <p>Tightening torque: 1.2 Nm \pm10%</p>  <p>xx1900001634</p>

Continues on next page

Concluding procedure

	Action	Note
1	<p>For robots with protection type Clean Room: Seal and paint the joints that have been opened. See Cut the paint or surface on the robot before replacing parts on page 118</p> <p> Note</p> <p>After all repair work, wipe the Clean Room robot free from particles with spirit on a lint free cloth.</p>	
2	Recalibrate the robot.	Calibration is detailed in section Calibration on page 771 .
3	<p> DANGER</p> <p>Make sure all safety requirements are met when performing the first test run. See Test run after installation, maintenance, or repair on page 56.</p>	

5 Repair

5.3.2 Replacing the internal harness

5.3.2 Replacing the internal harness

Location of the internal harness

The internal harness is located as shown in the figure.

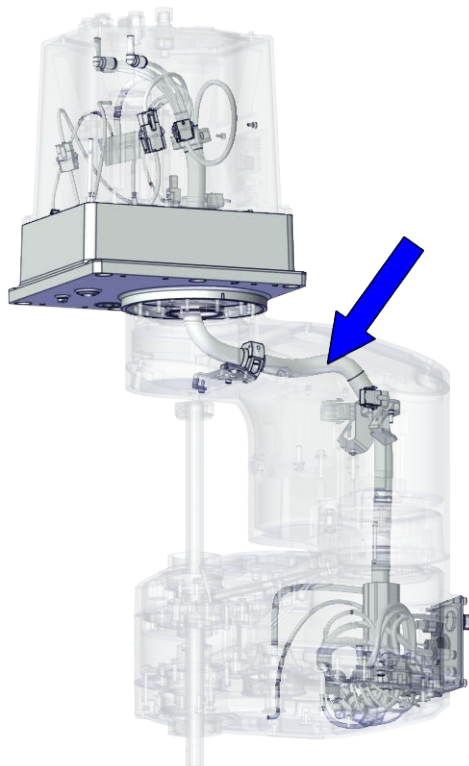

xx1800003406

Required spare parts



Note

The spare part numbers that are listed in the table can be out of date. See the latest spare parts of the IRB 910INV via myABB Business Portal, www.abb.com/myABB.

Spare part	Article number	Note
Internal harness, B	3HAC063752-007	Used for IRB 910INV-3/0.35
Internal harness, B	3HAC063752-008	Used for IRB 910INV-6/0.55
Internal harness, B+C1+A	3HAC063752-005	Used for IRB 910INV-3/0.35
Internal harness, B+C1+A	3HAC063752-006	Used for IRB 910INV-6/0.55
Internal harness, B+C1+C2+A	3HAC063752-001	Used for IRB 910INV-3/0.35
Internal harness, B+C1+C2+A	3HAC063752-001	Used for IRB 910INV-3/0.35

Continues on next page

Required tools and equipment

Equipment	Article number	Note
Standard toolkit	-	Content is defined in section Standard toolkit on page 840 .
Calibration tool box, Axis Calibration	3HAC074119-001	Delivered as a set of calibration tools. Required if Axis Calibration is the valid calibration method for the robot. ⁱ

ⁱ The robot is calibrated by either manual calibration or Axis Calibration at ABB factory before delivery. Always use the same calibration method as used at the factory.
Information about valid calibration method is found on the calibration label or in the calibration menu on the FlexPendant.
If no data is found related to standard calibration, manual calibration is used as default.

Required consumables

Consumable	Article number	Note
Cable straps	-	
Grease	3HAC029132-001	FM 222 Used to lubricate the cable harness.

Deciding calibration routine

Decide which calibration routine to be used, based on the information in the table. Depending on which routine is chosen, action might be required prior to beginning the repair work of the robot, see the table.

	Action	Note
1	Decide which calibration routine to use for calibrating the robot. <ul style="list-style-type: none"> Reference calibration. External cable packages (DressPack) and tools can stay fitted on the robot. Fine calibration. All external cable packages (DressPack) and tools must be removed from the robot. 	
	If the robot is to be calibrated with reference calibration: Find previous reference values for the axis or create new reference values. These values are to be used after the repair procedure is completed, for calibration of the robot. If no previous reference values exist, and no new reference values can be created, then reference calibration is not possible.	Follow the instructions given in the reference calibration routine on the FlexPendant to create reference values. Creating new values requires possibility to move the robot. Read more about reference calibration for Axis Calibration in Reference calibration routine on page 798 .
	If the robot is to be calibrated with fine calibration: Remove all external cable packages (DressPack) and tools from the robot.	

Continues on next page

5 Repair



5.3.2 Replacing the internal harness

Continued

Removing the internal harness

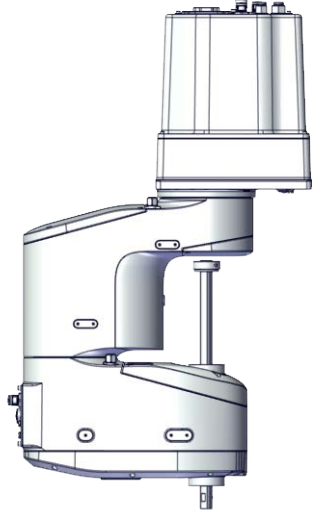

Use these procedures to remove the internal harness.

Preparations before removing the inner arm

	Action	Note
1	Decide which calibration routine to use, and take actions accordingly prior to beginning the repair procedure.	
2	<p>If there is no enough space for the maintenance work, remove the robot from the wall and place it on the maintenance bracket.</p> <p> CAUTION</p> <p>Do not lay down the robot during the transportation, always keep it straight. If the robot lay down in any situation, the grease may come out from gearbox.</p>	
3	Jog all axes to zero position.	 <p>xx1800002825</p>
4	<p> DANGER</p> <p>Turn off all:</p> <ul style="list-style-type: none"> • electric power supply • hydraulic pressure supply • air pressure supply <p>to the robot, before entering the safeguarded space.</p>	
5	<p> CAUTION</p> <p>For robots with protection type Clean Room Always cut the paint with a knife and grind the paint edge when disassembling parts of the robot! See Cut the paint or surface on the robot before replacing parts on page 118.</p>	

Continues on next page

Removing the base cover

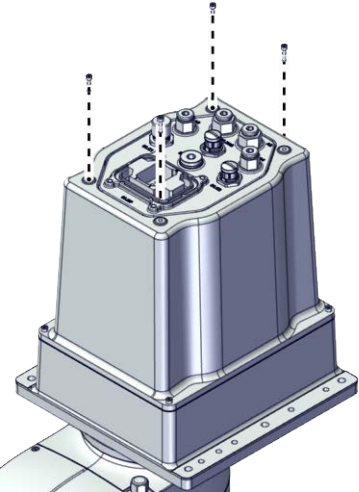
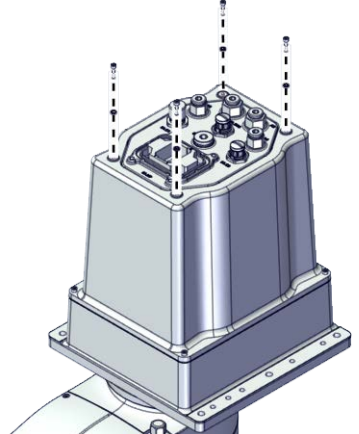
	Action	Note
1	 <p>DANGER</p> <p>Make sure that all supplies for electrical power, hydraulic pressure, and air pressure are turned off.</p>	
2	 <p>CAUTION</p> <p>For robots with protection type Clean Room Always cut the paint with a knife and grind the paint edge when disassembling parts of the robot! See <i>Cut the paint or surface on the robot before replacing parts on page 118.</i></p>	
3	<p>Remove the screws on the base cover to the base harness.</p>  <p>Note</p> <p>For robots with protection class IP54 (option 3350-540) For robots with protection type Clean Room (option 3351-1) Remove the extra sealing washers on the base cover to the base harness.</p>	<p>For robots with protection class IP30 (option 3350-300)</p>  <p>xx1800002826</p> <p>For robots with protection class IP54 (option 3350-540) For robots with protection type Clean Room (option 3351-1)</p>  <p>xx1900001634</p>

Continues on next page



5 Repair

5.3.2 Replacing the internal harness

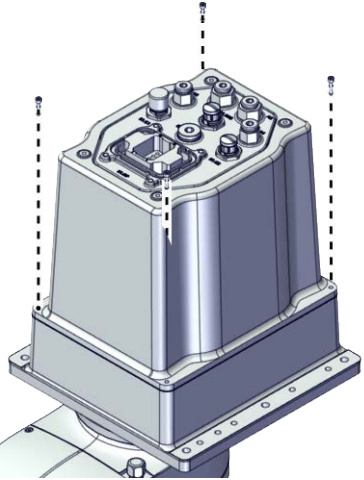
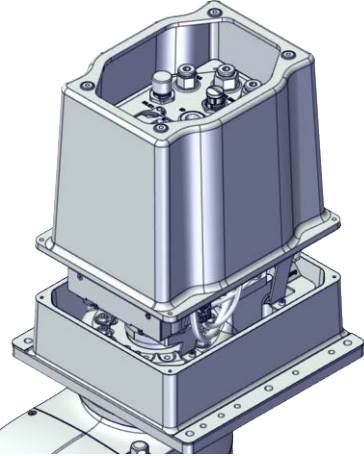
Continued

	Action	Note
4	Remove the screws on the base cover to the base.	 <p>xx1800002827</p>
5	Take the base cover out.	 <p>xx1800002828</p>



Removing the cover of the inner arm

	Action	Note
1	 <p>DANGER</p> <p>Make sure that all supplies for electrical power, hydraulic pressure, and air pressure are turned off.</p>	
2	 <p>CAUTION</p> <p>For robots with protection type Clean Room Always cut the paint with a knife and grind the paint edge when disassembling parts of the robot! See Cut the paint or surface on the robot before replacing parts on page 118.</p>	

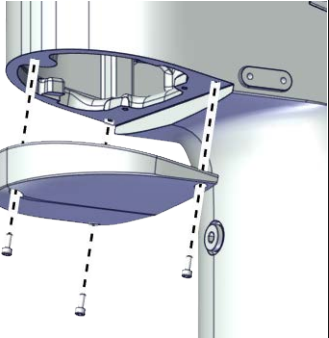
Continues on next page

	Action	Note
3	Remove the screws.	 <p>xx1800002899</p>
4	Remove the cover.	

Removing the casting cover of the inner arm

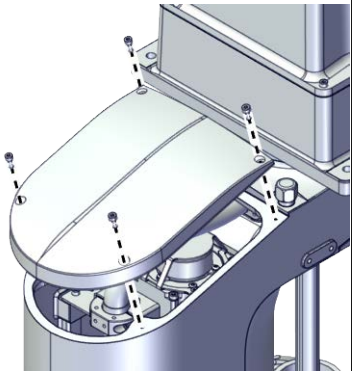
	Action	Note
1	 <p>DANGER</p> <p>Make sure that all supplies for electrical power, hydraulic pressure, and air pressure are turned off.</p>	
2	 <p>CAUTION</p> <p>For robots with protection type Clean Room Always cut the paint with a knife and grind the paint edge when disassembling parts of the robot! See Cut the paint or surface on the robot before replacing parts on page 118.</p>	
3	Remove the screws.	 <p>xx1800002873</p>
4	Remove the casting cover.	

Removing the lower cover

	Action	Note
1	 <p>DANGER</p> <p>Make sure that all supplies for electrical power, hydraulic pressure, and air pressure are turned off.</p>	

Continues on next page



5 Repair

5.3.2 Replacing the internal harness

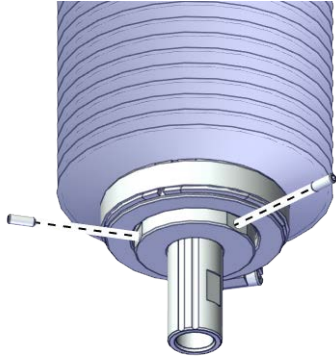
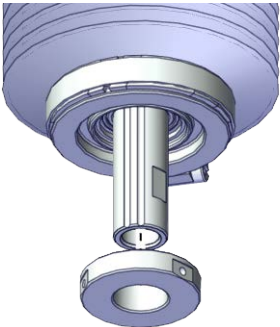



Continued

	Action	Note
2	 CAUTION For robots with protection type Clean Room Always cut the paint with a knife and grind the paint edge when disassembling parts of the robot! See Cut the paint or surface on the robot before replacing parts on page 118 .	
3	For robots with protection class IP54 (option 3350-540) For robots with protection type Clean Room (option 3351-1) Loose the locking screws.	 <small>xx1900001606</small>
4	For robots with protection class IP54 (option 3350-540) For robots with protection type Clean Room (option 3351-1) Remove the lower cover from the ball screw.	 <small>xx1900001607</small>

Removing the cover of the outer arm

	Action	Note
1	 DANGER Make sure that all supplies for electrical power, hydraulic pressure, and air pressure are turned off.	
2	 CAUTION For robots with protection type Clean Room Always cut the paint with a knife and grind the paint edge when disassembling parts of the robot! See Cut the paint or surface on the robot before replacing parts on page 118 .	

Continues on next page

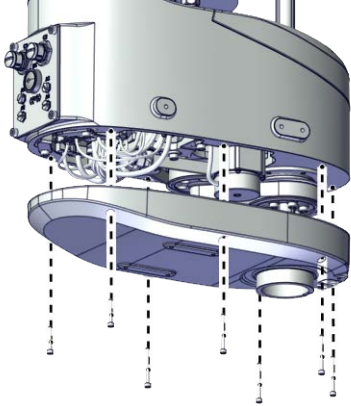
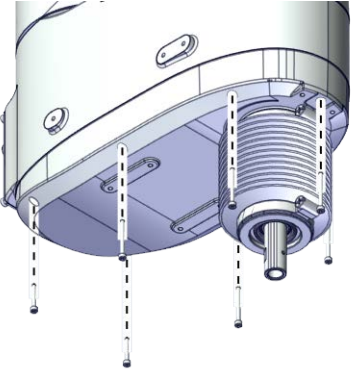
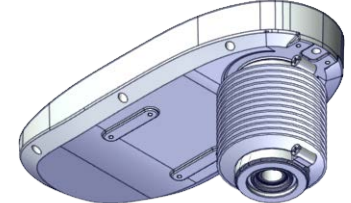
	Action	Note
3	<p>Remove the screws on the cover of the outer arm and remove the cover.</p> <p> Note</p> <p>For robots with protection class IP54 (option 3350-540)</p> <p>For robots with protection type Clean Room (option 3351-1)</p> <p>Remove the cover with bellow and housing.</p> <p> Note</p> <p>The bellow does not need to be removed separately.</p> <p> CAUTION</p> <p>There is a gasket in the cover. Be careful when removing the cover with bellow and housing.</p> <p> Tip</p> <p>Check the gasket and replace it if needed.</p>	<p>For robots with protection class IP30 (option 3350-300)</p>  <p>xx1800002836</p> <p>For robots with protection class IP54 (option 3350-540)</p> <p>For robots with protection type Clean Room (option 3351-1)</p>  <p>xx1900001631</p>  <p>xx1900001632</p>

Disconnecting the connectors on the base harness



	Action	Note
1	<p> DANGER</p> <p>Make sure that all supplies for electrical power, hydraulic pressure, and air pressure are turned off.</p>	

Continues on next page

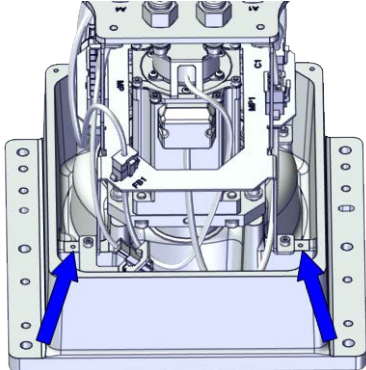

5 Repair

5.3.2 Replacing the internal harness

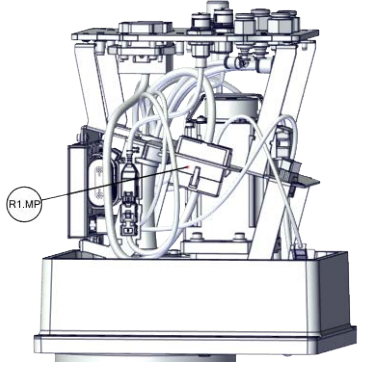



Continued

	Action	Note
2	 CAUTION For robots with protection type Clean Room Always cut the paint with a knife and grind the paint edge when disassembling parts of the robot! See Cut the paint or surface on the robot before replacing parts on page 118 .	
3	Remove the three grounding cables from the bracket by unscrew the screws.	 xx190000062
4	Disconnect the connector. <ul style="list-style-type: none"> R1.MP  Tip Take photos of the connector and cable position before disconnecting them, to have as a reference when reconnecting.	 xx1800002829

Disconnecting the air hoses, C1 cabling and C2 cabling (if equipped)

	Action	Note
1	 DANGER Make sure that all supplies for electrical power, hydraulic pressure, and air pressure are turned off.	
2	 CAUTION For robots with protection type Clean Room Always cut the paint with a knife and grind the paint edge when disassembling parts of the robot! See Cut the paint or surface on the robot before replacing parts on page 118 .	

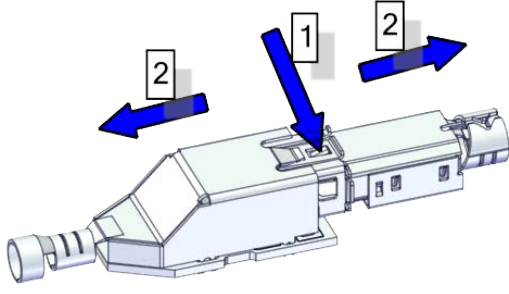
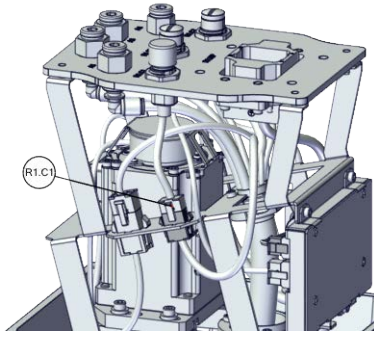
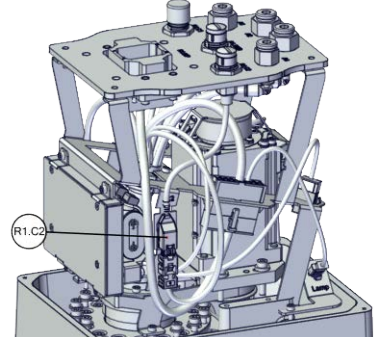
Continues on next page

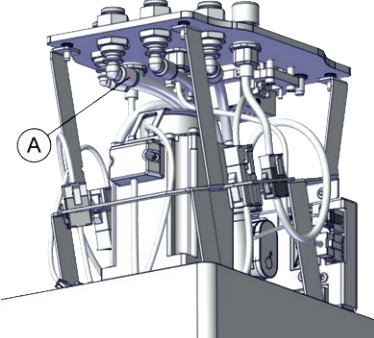
	Action	Note		
3	<p>Cut the cable straps and disconnect the connectors.</p> <ul style="list-style-type: none"> • R1.C1 • R1.C2 <p> Tip</p> <p>Take photos of the connector and cable position before disconnecting them, to have as a reference when reconnecting.</p> <p> Tip</p> <p>The connector clip has to be pressed (1) and pushed forward (2) to separate the R1.C2 (for C2 cabling).</p>  <p>xx1800002943</p>	 <p>xx1800002831</p>  <p>xx1800002832</p>		
4	<p>Disconnect the air hoses from the L-shaped connectors.</p> <p> Note</p> <p>Make sure that the air hoses are not bent or broken when you disconnect them.</p>	 <p>xx1800002830</p> <table border="1" data-bbox="1061 1601 1436 1657"> <tr> <td data-bbox="1061 1601 1117 1657">A</td> <td data-bbox="1117 1601 1436 1657">Air hoses</td> </tr> </table>	A	Air hoses
A	Air hoses			

Disconnecting the SMB cabling



	Action	Note
1	<p> DANGER</p> <p>Make sure that all supplies for electrical power, hydraulic pressure, and air pressure are turned off.</p>	

Continues on next page



5 Repair

5.3.2 Replacing the internal harness

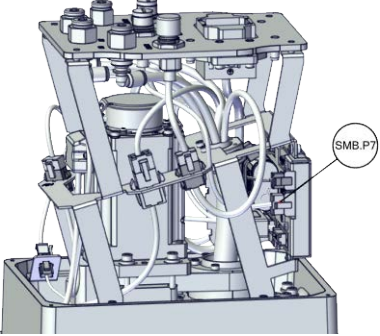
Continued

	Action	Note
2	 ELECTROSTATIC DISCHARGE (ESD) The unit is sensitive to ESD. Before handling the unit read the safety information in section The unit is sensitive to ESD on page 45 .	
3	 CAUTION For robots with protection type Clean Room Always cut the paint with a knife and grind the paint edge when disassembling parts of the robot! See Cut the paint or surface on the robot before replacing parts on page 118 .	
4	Disconnect the connectors. <ul style="list-style-type: none"> • SMB.P7 • SMB.J1 (Only when the internal harness)  Tip Take photos of the connector and cable position before disconnecting them, to have as a reference when reconnecting.	 <p>xx1800002833</p>



Removing the base harness

	Action	Note
1	 DANGER Make sure that all supplies for electrical power, hydraulic pressure, and air pressure are turned off.	
2	 CAUTION For robots with protection type Clean Room Always cut the paint with a knife and grind the paint edge when disassembling parts of the robot! See Cut the paint or surface on the robot before replacing parts on page 118 .	

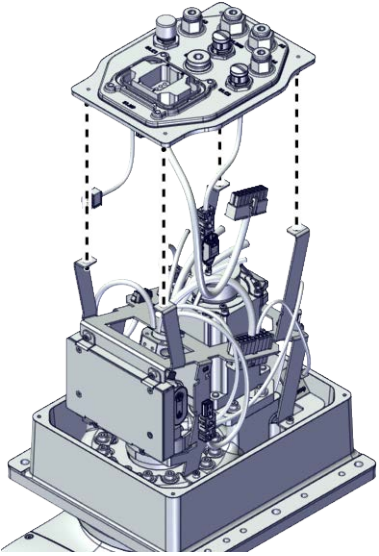
Continues on next page

	Action	Note
3	Remove the base harness from the bracket.	 <p data-bbox="1061 869 1173 891">xx1800002834</p>

Removing the bracket

	Action	Note
1	 <p data-bbox="603 1070 715 1099">DANGER</p> <p data-bbox="512 1128 1038 1205">Make sure that all supplies for electrical power, hydraulic pressure, and air pressure are turned off.</p>	
2	 <p data-bbox="603 1272 715 1301">CAUTION</p> <p data-bbox="512 1330 1038 1469">For robots with protection type Clean Room Always cut the paint with a knife and grind the paint edge when disassembling parts of the robot! See Cut the paint or surface on the robot before replacing parts on page 118.</p>	

Continues on next page

5 Repair

5.3.2 Replacing the internal harness

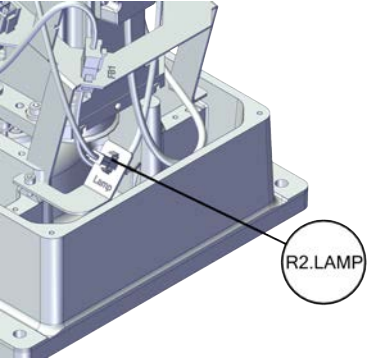
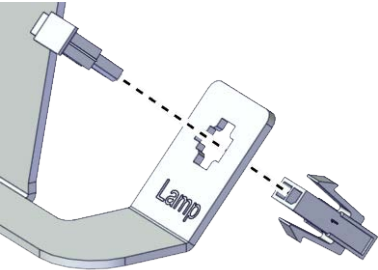
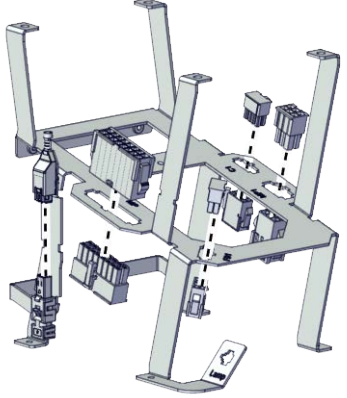
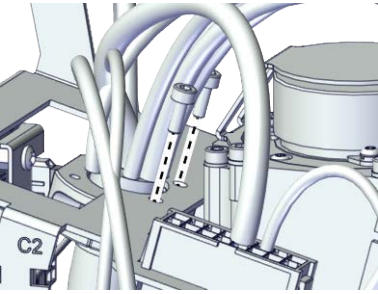

Continued

	Action	Note
3	Disconnect the lamp connector on the bracket.	 <p>xx1800002867</p>  <p>xx1900000079</p>
4	Snap loose and remove the female head of the connectors from the bracket.	 <p>xx1900000081</p>
5	Release the cable ferrule from the bracket.	 <p>xx1900000080</p>

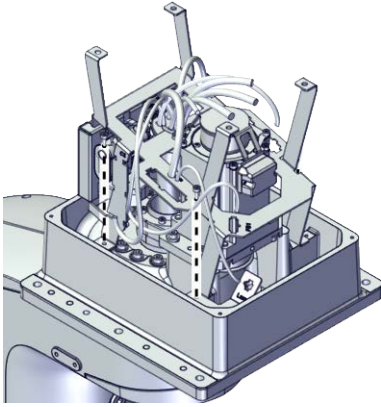
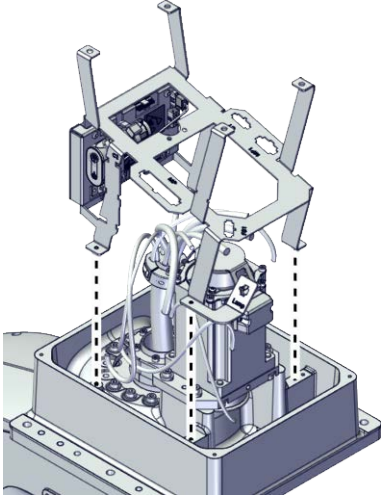
Continues on next page

	Action	Note
6	Remove the screws on the bracket.	 <p>xx1800002868</p>
7	Remove the bracket.	 <p>xx1800002869</p>

Removing the bracket for the process hub

	Action	Note
1	 <p>DANGER</p> <p>Make sure that all supplies for electrical power, hydraulic pressure, and air pressure are turned off.</p>	
2	 <p>CAUTION</p> <p>For robots with protection type Clean Room Always cut the paint with a knife and grind the paint edge when disassembling parts of the robot! See Cut the paint or surface on the robot before replacing parts on page 118.</p>	

Continues on next page



5 Repair

5.3.2 Replacing the internal harness

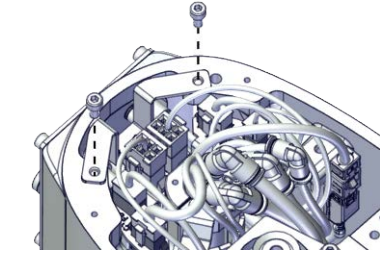
Continued

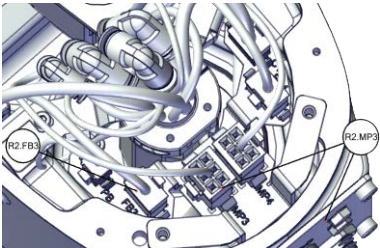
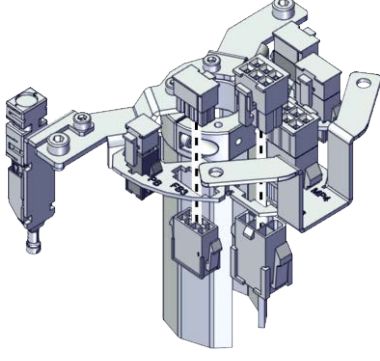

	Action	Note
3	Remove the screws on the bracket and take it out carefully.	 xx1800002839

Disconnecting the connectors for axis-3 motor

	Action	Note
1	 DANGER Make sure that all supplies for electrical power, hydraulic pressure, and air pressure are turned off.	
2	 CAUTION For robots with protection type Clean Room Always cut the paint with a knife and grind the paint edge when disassembling parts of the robot! See Cut the paint or surface on the robot before replacing parts on page 118 .	
3	Disconnect the connectors. <ul style="list-style-type: none"> • R2.MP3 • R2.FB3 	 xx1900000063
4	Snap loose and remove the female head of the connectors from the bracket.	 xx1900000064

Continues on next page

Disconnecting the connectors for axis-4 motor

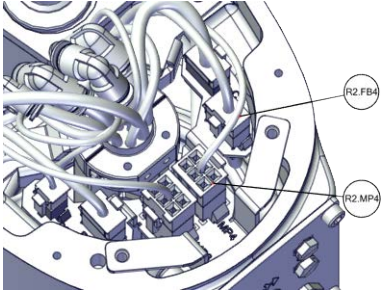
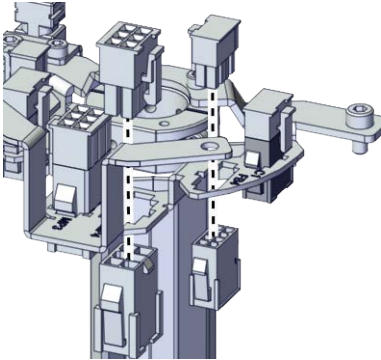
	Action	Note
1	 DANGER Make sure that all supplies for electrical power, hydraulic pressure, and air pressure are turned off.	
2	 CAUTION For robots with protection type Clean Room Always cut the paint with a knife and grind the paint edge when disassembling parts of the robot! See Cut the paint or surface on the robot before replacing parts on page 118 .	
3	Disconnect the connectors. <ul style="list-style-type: none"> • R2.MP4 • R2.FB4 	 <p>xx1900000065</p>
4	Snap loose and remove the female head of the connectors from the bracket.	 <p>xx1900000066</p>

Disconnecting the connector for PB

	Action	Note
1	 DANGER Make sure that all supplies for electrical power, hydraulic pressure, and air pressure are turned off.	

Continues on next page



5 Repair

5.3.2 Replacing the internal harness

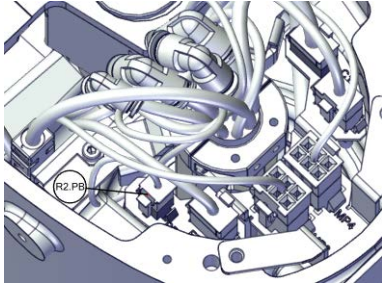
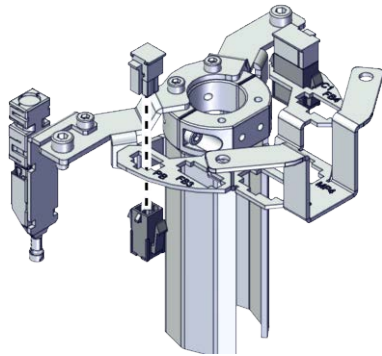



Continued

	Action	Note
2	 CAUTION For robots with protection type Clean Room Always cut the paint with a knife and grind the paint edge when disassembling parts of the robot! See Cut the paint or surface on the robot before replacing parts on page 118.	
3	Disconnect the connector. <ul style="list-style-type: none"> R2.PB 	 xx190000068
4	Snap loose and remove the female head of the connector from the bracket.	 xx190000069

Disconnecting the air hoses, C1 cabling and C2 cabling (if equipped)

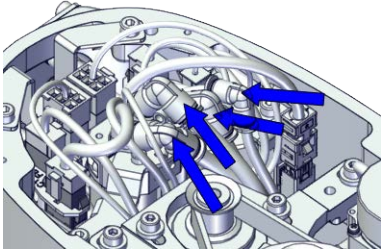
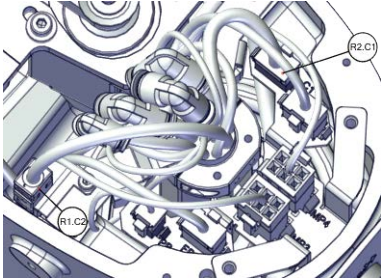
	Action	Note
1	 DANGER Make sure that all supplies for electrical power, hydraulic pressure, and air pressure are turned off.	
2	 CAUTION For robots with protection type Clean Room Always cut the paint with a knife and grind the paint edge when disassembling parts of the robot! See Cut the paint or surface on the robot before replacing parts on page 118.	

Continues on next page

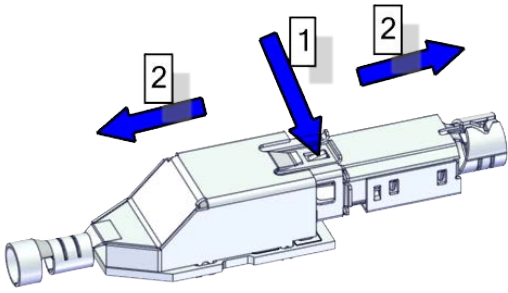
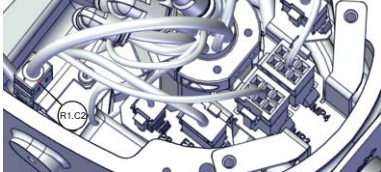
	Action	Note
3	<p>Disconnect the air hoses from the L-shaped connectors.</p>	 <p>xx1800002837</p>
4	<p>For robots with C1 cabling Disconnect the connector.</p> <ul style="list-style-type: none"> • R2.C1 	 <p>xx1900000070</p>
5	<p>For robots with C2 cabling Disconnect the connector.</p> <ul style="list-style-type: none"> • R1.C2 <p> Tip</p> <p>Cut the cable straps for the R1.C2 at the same time.</p> <p> Tip</p> <p>Take photos of the connector and cable position before disconnecting them, to have as a reference when reconnecting.</p> <p> Tip</p> <p>The connector clip has to be pressed (1) and pushed forward (2) to separate the R1.C2 (for C2 cabling).</p>  <p>xx1800002943</p>	 <p>xx1900000070</p>

Continues on next page



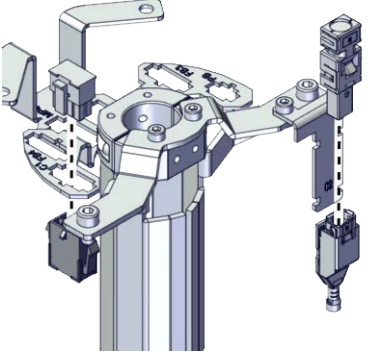

5 Repair

5.3.2 Replacing the internal harness

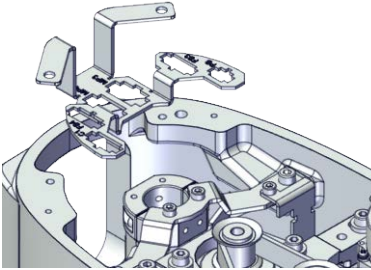

Continued

	Action	Note
6	Snap loose and remove the female head of the connectors from the bracket.	 <p>xx1900000071</p>

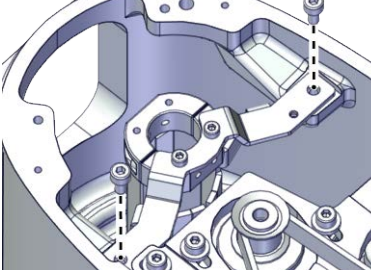
Removing the cable ferrule, bracket and protected bracket

	Action	Note
1	 DANGER Make sure that all supplies for electrical power, hydraulic pressure, and air pressure are turned off.	
2	 CAUTION For robots with protection type Clean Room Always cut the paint with a knife and grind the paint edge when disassembling parts of the robot! See Cut the paint or surface on the robot before replacing parts on page 118.	
3	Take out the bracket from the outer arm.  Note The harness are not visible due to the cleanness requirements of the illustration. They are still existing inside the cable ferrule in the actual situation.	 <p>xx1900000073</p>
4	Remove the screws on the protected bracket.  Note The harness are not visible due to the cleanness requirements of the illustration. They are still existing inside the cable ferrule in the actual situation.	 <p>xx1900000074</p>

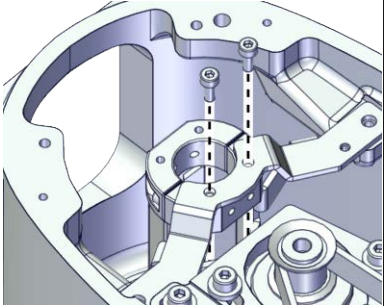
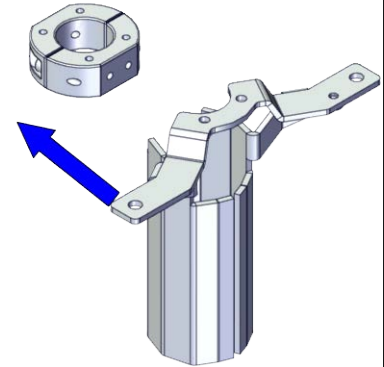
Continues on next page

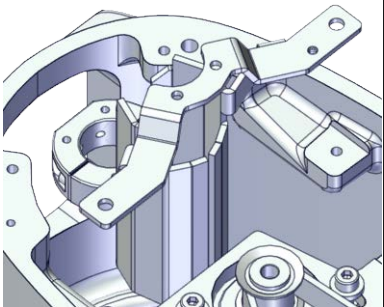
	Action	Note
5	<p>Remove the screws on the protected bracket to the cable ferrule to release the cable ferrule with cable.</p> <p> Note</p> <p>The harness are not visible due to the cleanness requirements of the illustration. They are still existing inside the cable ferrule in the actual situation.</p>	 <p>xx1900000075</p>  <p>xx1900000076</p>
6	<p>Remove the protected bracket.</p> <p> Tip</p> <p>Pull the protected bracket to the ball screw side to push the cable with the cable ferrule out from the protected bracket.</p> <p> Note</p> <p>The harness are not visible due to the cleanness requirements of the illustration. They are still existing inside the cable ferrule in the actual situation.</p>	 <p>xx1900000078</p>

Continues on next page



5 Repair

5.3.2 Replacing the internal harness

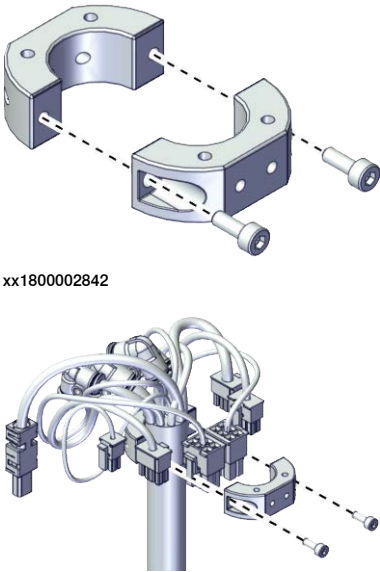
Continued



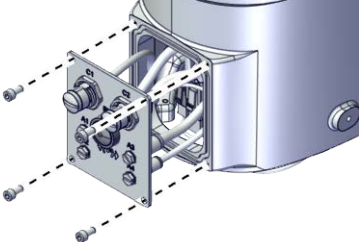

	Action	Note
7	Remove the screws on the cable ferrule and take the cable ferrule out.	 <p data-bbox="1029 584 1136 604">xx1800002842</p> <p data-bbox="1029 891 1136 911">xx1800002849</p>

Pull out the process hub

	Action	Note
1	 <p data-bbox="571 1093 679 1122">DANGER</p> <p data-bbox="480 1151 1007 1234">Make sure that all supplies for electrical power, hydraulic pressure, and air pressure are turned off.</p>	
2	 <p data-bbox="571 1294 687 1323">CAUTION</p> <p data-bbox="480 1352 1018 1491">For robots with protection type Clean Room Always cut the paint with a knife and grind the paint edge when disassembling parts of the robot! See Cut the paint or surface on the robot before replacing parts on page 118.</p>	
3	<p data-bbox="480 1532 983 1581">Remove the screws and carefully pull out the process hub.</p>  <p data-bbox="571 1615 687 1644">CAUTION</p> <p data-bbox="480 1673 1018 1778">Be aware of the cabling that is attached to the cover! The cover can not be removed completely until the connectors are disconnected, as shown in following steps.</p>	 <p data-bbox="1029 1787 1136 1807">xx1800002848</p>

Continues on next page

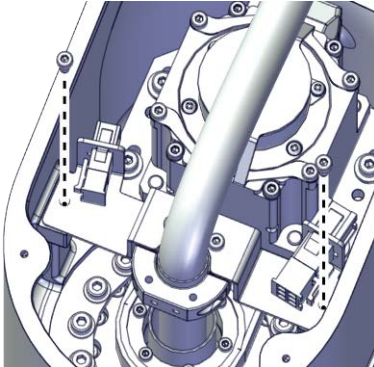
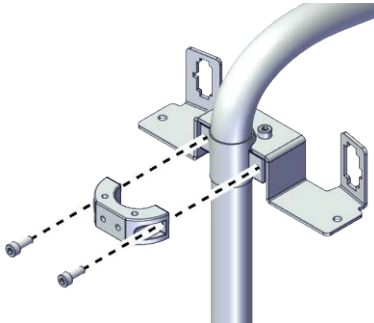
Removing the cable bracket at the axis -2 motor position in the inner arm

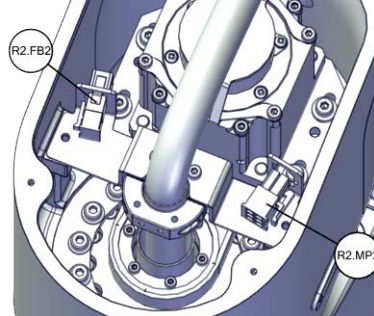
	Action	Note
1	 DANGER Make sure that all supplies for electrical power, hydraulic pressure, and air pressure are turned off.	
2	 CAUTION For robots with protection type Clean Room Always cut the paint with a knife and grind the paint edge when disassembling parts of the robot! See Cut the paint or surface on the robot before replacing parts on page 118 .	
3	Remove the screws.	 <p>xx1800002874</p>
4	Remove the screws on the cable ferrule to release the cable.	 <p>xx1800002876</p>
5	Disconnect the connectors. <ul style="list-style-type: none"> • R2.MP2 • R2.FB2  Tip Take photos of the connector and cable position before disconnecting them, to have as a reference when reconnecting.	 <p>xx1800002875</p>



Continues on next page

5 Repair

5.3.2 Replacing the internal harness

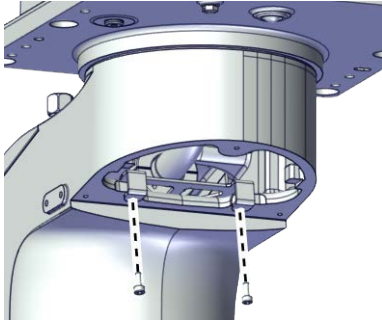
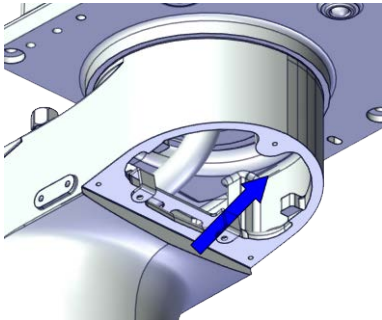
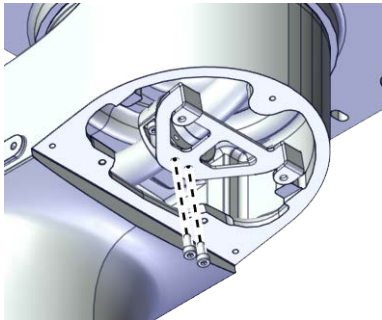

Continued

Removing the bracket at the axis -1 gearbox position in the inner arm



	Action	Note
1	 DANGER Make sure that all supplies for electrical power, hydraulic pressure, and air pressure are turned off.	
2	 CAUTION For robots with protection type Clean Room Always cut the paint with a knife and grind the paint edge when disassembling parts of the robot! See Cut the paint or surface on the robot before replacing parts on page 118 .	
3	Remove the screws.	 xx1800003408
4	Remove the bracket from the inner arm and take it out with the cable slightly.	 xx1900000099 <i>Figure 5.1:</i>
5	Remove the bracket from the cable ferrule by removing the screws.	 xx1800003409

Continues on next page

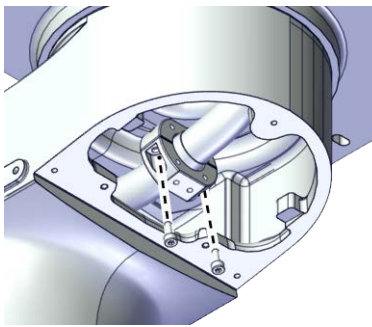
Removing the cable ferrule at the axis -1 gearbox position in the inner arm

	Action	Note
1	 DANGER Make sure that all supplies for electrical power, hydraulic pressure, and air pressure are turned off.	
2	 CAUTION For robots with protection type Clean Room Always cut the paint with a knife and grind the paint edge when disassembling parts of the robot! See Cut the paint or surface on the robot before replacing parts on page 118 .	
3	Remove the screws.	 xx1800003410
4	Remove the cable ferrule on the cable and take it out.	

Removing the internal harness from the axis -2 gearbox position



	Action	Note
1	 DANGER Make sure that all supplies for electrical power, hydraulic pressure, and air pressure are turned off.	
2	 CAUTION For robots with protection type Clean Room Always cut the paint with a knife and grind the paint edge when disassembling parts of the robot! See Cut the paint or surface on the robot before replacing parts on page 118 .	
3	Cut the cable straps for R2.MP3 and R2.MP4.  Tip Take photos of the cable straps position before cutting them, to have as a reference when routing the cable.	

Continues on next page



5 Repair

5.3.2 Replacing the internal harness

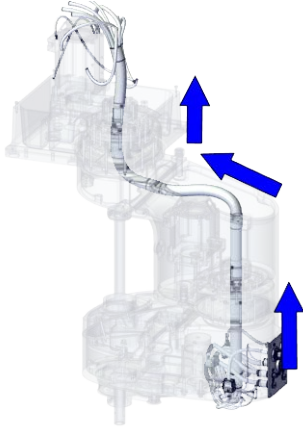
Continued

	Action	Note
4	<p>Pull the internal harness out of the outer arm from the centre of the axis-2 gearbox.</p> <p> Tip</p> <p>Wrap the connectors with the masking tape.</p> <p> Tip</p> <p>Take photos of the connector and cable position before disconnecting them, to have as a reference when reconnecting.</p>	 <p>xx1800003411</p>

Removing the internal harness from the inner arm

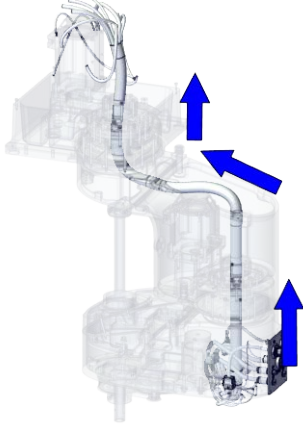



	Action	Note
1	<p> DANGER</p> <p>Make sure that all supplies for electrical power, hydraulic pressure, and air pressure are turned off.</p>	
2	<p> CAUTION</p> <p>For robots with protection type Clean Room</p> <p>Always cut the paint with a knife and grind the paint edge when disassembling parts of the robot! See Cut the paint or surface on the robot before replacing parts on page 118.</p>	
3	<p>Pull the internal harness out of the inner arm from the sleeve of the axis-1 gearbox.</p> <p> Tip</p> <p>Wrap the connectors with the masking tape.</p>	 <p>xx1800003411</p>

Continues on next page

Refitting the internal harness

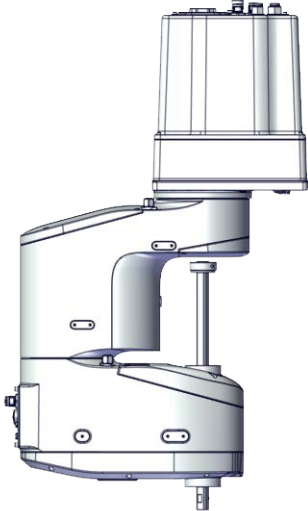
Use these procedures to refit the internal harness.

Inserting the internal harness through the inner arm

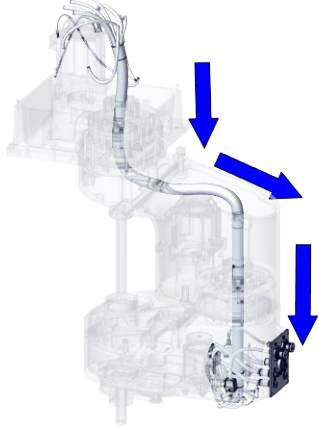
	Action	Note
1	<p>For robots with protection type Clean Room: Clean the joints that have been opened and wipe the parts free from particles with spirit on a lint free. See Cut the paint or surface on the robot before replacing parts on page 118</p> <p> Note</p> <p>After all repair work, wipe the Clean Room robot free from particles with spirit on a lint free cloth.</p>	
2	<p>Make sure that the robot is at zero position.</p>	 <p>xx1800002825</p>
3	<p>Insert the internal harness into the inner arm through the sleeve of the axis-1 gearbox from the base.</p> <p> Tip</p> <p>Wrap the connectors with the masking tape.</p> <p> Tip</p> <p>The air hoses should face the axis-1 motor.</p> <p> CAUTION</p> <p>Make sure that no cables or hoses are twisted or strained. Reroute if necessary.</p>	 <p>xx1800003412</p>



Continues on next page

5 Repair

5.3.2 Replacing the internal harness

Continued

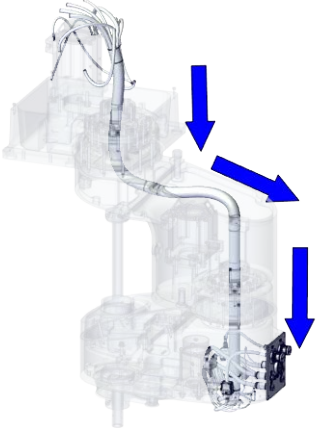

Inserting the internal harness through the axis -2 gearbox position

	Action	Note
1	<p>For robots with protection type Clean Room: Clean the joints that have been opened and wipe the parts free from particles with spirit on a lint free. See Cut the paint or surface on the robot before replacing parts on page 118</p> <p> Note</p> <p>After all repair work, wipe the Clean Room robot free from particles with spirit on a lint free cloth.</p>	
2	<p>Insert the internal harness into the outer arm through the centre of the axis-2 gearbox.</p> <p> Tip</p> <p>Wrap the connectors with the masking tape.</p>	 <p>xx1800003412</p>
3	Secure the R2.MP3 and R2.MP4 with cable straps.	

Refitting the cable ferrule at the axis -1 gearbox position in the inner arm

	Action	Note
1	<p>For robots with protection type Clean Room: Clean the joints that have been opened and wipe the parts free from particles with spirit on a lint free. See Cut the paint or surface on the robot before replacing parts on page 118</p> <p> Note</p> <p>After all repair work, wipe the Clean Room robot free from particles with spirit on a lint free cloth.</p>	
2	Lay the internal harness in a natural state without distortion.	

Continues on next page

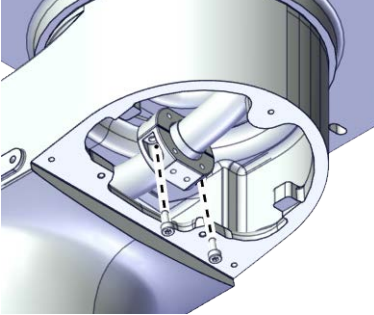
	Action	Note
3	<p>Refit the cable ferrule on the cable at the marked position and secure with screws.</p> <p> Tip</p> <p>The position with wrapped tape is the marked position for the cable ferrule.</p> <p> Tip</p> <p>Align all the cable ferrules so that the cable is in a natural bending position to avoid twisting.</p>	<p>Screws: Hex socket head cap screw M3x8 12.9 Lafre 2C2B/FC6.9 (2 pcs)</p> <p>Tightening torque: 1.5 Nm ±10%</p>  <p>xx1800003410</p>

Refitting the bracket at the axis -1 gearbox position in the inner arm

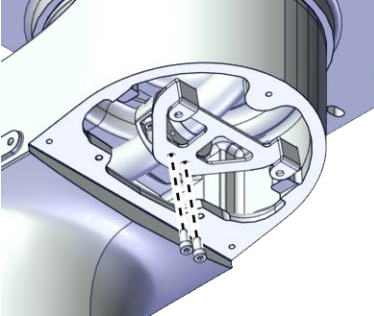
	Action	Note
1	<p>For robots with protection type Clean Room: Clean the joints that have been opened and wipe the parts free from particles with spirit on a lint free. See Cut the paint or surface on the robot before replacing parts on page 118</p> <p> Note</p> <p>After all repair work, wipe the Clean Room robot free from particles with spirit on a lint free cloth.</p>	
2	<p>Refit the cable ferrule to the bracket and secure with the screws.</p>	<p>Screws: Hex socket head cap screw M3x5 12.9 Lafre 2C2B/FC6.9 (2 pcs)</p> <p>Tightening torque: 1.5 Nm ±10%</p>  <p>xx1800003409</p>

Continues on next page



5 Repair

5.3.2 Replacing the internal harness

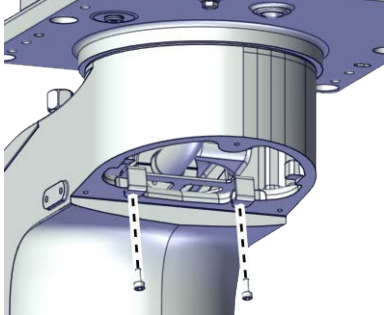

Continued

	Action	Note
3	Refit the bracket into the inner arm and secure with the screws.	<p>Screws: Hex socket head cap screw M3x5 12.9 Lafre 2C2B/FC6.9 (2 pcs)</p> <p>Tightening torque: 1.5 Nm \pm10%</p>  <p>xx1800003408</p>

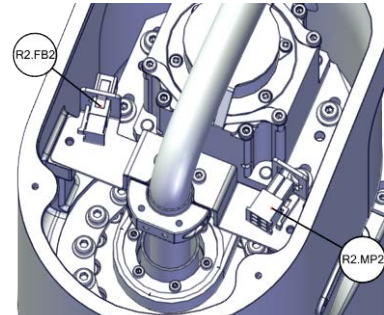
Refitting the cable bracket

	Action	Note
1	<p>For robots with protection type Clean Room: Clean the joints that have been opened and wipe the parts free from particles with spirit on a lint free. See Cut the paint or surface on the robot before replacing parts on page 118</p> <p> Note</p> <p>After all repair work, wipe the Clean Room robot free from particles with spirit on a lint free cloth.</p>	
2	<p>Reconnect the connectors.</p> <ul style="list-style-type: none"> • R2.MP2 • R2.FB2 <p> Tip</p> <p>Take photos of the connector and cable position before disconnecting them, to have as a reference when reconnecting.</p> <p> Tip</p> <p>See the number markings on the connectors for help to find the corresponding connector.</p>	 <p>xx1800002875</p>
3	Lay the internal harness in a natural state without distortion.	

Continues on next page

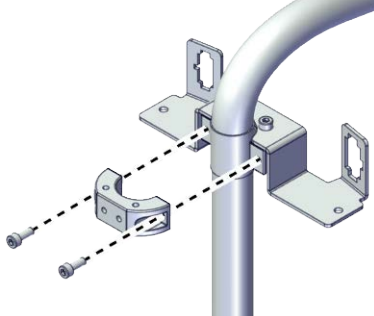
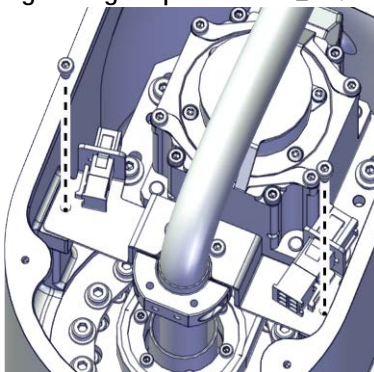
	Action	Note
4	<p>Refit the cable ferrule on the cable at the marked position and secure with screws.</p> <p> Tip</p> <p>The position with wrapped tape is the marked position for the cable ferrule.</p> <p> Tip</p> <p>Align all the cable ferrules so that the cable is in a natural bending position to avoid twisting.</p>	<p>Screws: Hex socket head cap screw M3x8 12.9 Lafre 2C2B/FC6.9 (2 pcs)</p> <p>Tightening torque: 1.5 Nm ±10%</p>  <p>xx1800002876</p>
5	<p>Refit the bracket and secure with the screws.</p>	<p>Screws: Hex socket head cap screw M3x5 12.9 Lafre 2C2B/FC6.9 (2 pcs)</p> <p>Tightening torque: 1.5 Nm ±10%</p>  <p>xx1800002874</p>



Refitting the process hub

	Action	Note
1	<p>For robots with protection type Clean Room: Clean the joints that have been opened and wipe the parts free from particles with spirit on a lint free. See Cut the paint or surface on the robot before replacing parts on page 118</p> <p> Note</p> <p>After all repair work, wipe the Clean Room robot free from particles with spirit on a lint free cloth.</p>	

5 Repair

5.3.2 Replacing the internal harness



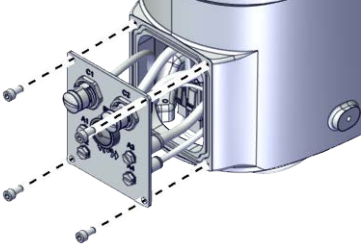
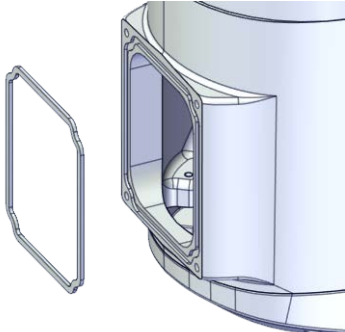

Continued

	Action	Note
2	<p>Refit the process hub to the outer arm and secure it with the screws.</p> <p> Note</p> <p>For robots with protection class IP54 (option 3350-540) For robots with protection type Clean Room (option 3351-1) Check the gasket for the process hub on the outer arm.</p> <p> Tip</p> <p>Replace the gasket if needed.</p> <p> CAUTION</p> <p>Be aware of the cabling that is attached to the cover! The cover can not be removed completely until the connectors are disconnected, as shown in following steps.</p>	<p>Screws: Hex socket head cap screw M4x8 12.9 Lafre 2C2B/FC6.9 (4 pcs) Tightening torque: 4 Nm \pm10%</p>  <p>xx1800002848</p> <p>For robots with protection class IP54 (option 3350-540) For robots with protection type Clean Room (option 3351-1)</p>  <p>xx1900001638</p>

Refitting the cable ferrule and protected bracket

	Action	Note
1	<p>For robots with protection type Clean Room: Clean the joints that have been opened and wipe the parts free from particles with spirit on a lint free. See Cut the paint or surface on the robot before replacing parts on page 118</p> <p> Note</p> <p>After all repair work, wipe the Clean Room robot free from particles with spirit on a lint free cloth.</p>	
2	<p>Lay the internal harness in a natural state without distortion.</p>	

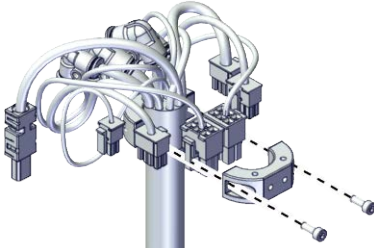
Continues on next page

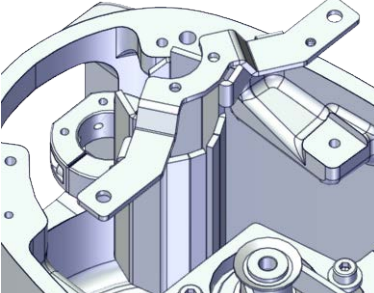

	Action	Note
3	<p>Refit the cable ferrule and secure it with the screws.</p> <p> Tip</p> <p>The air hoses should face the process hub side.</p> <p> Tip</p> <p>The position with wrapped tape is the marked position for the cable ferrule.</p> <p> Tip</p> <p>Align all the cable ferrules so that the cable is in a natural bending position to avoid twisting.</p>	<p>Screws: Hex socket head cap screw M3x8 12.9 Lafre 2C2B/FC6.9 (2 pcs)</p> <p>Tightening torque: 1.5 Nm ±10%</p>  <p>xx1800002849</p>
4	<p>Refit the protected bracket.</p> <p> Tip</p> <p>Do not secure it with the screws before the cable ferrule installed well.</p> <p> Note</p> <p>The harness are not visible due to the cleanness requirements of the illustration. They are still existing inside the cable ferrule in the actual situation.</p>	<p>Screws: Hex socket head cap screw M4x8 12.9 Lafre 2C2B/FC6.9 (2 pcs)</p> <p>Tightening torque: 4 Nm ±10%</p>  <p>xx1900000078</p>

Continues on next page

5 Repair

5.3.2 Replacing the internal harness



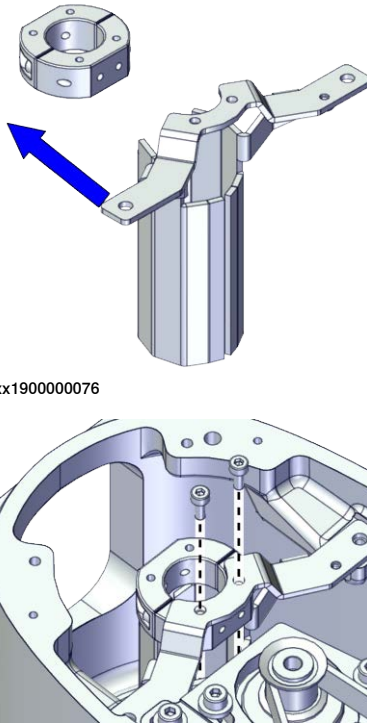

Continued

	Action	Note
5	<p>Secure the cable ferrule to the protected bracket.</p> <p> Tip</p> <p>Align all the cable ferrules so that the cable is in a natural bending position to avoid twisting.</p> <p> Note</p> <p>The harness are not visible due to the cleanliness requirements of the illustration. They are still existing inside the cable ferrule in the actual situation.</p>	<p>Screws: Hex socket head cap screw M3x5 12.9 Lafre 2C2B/FC6.9 (2 pcs)</p> <p>Tightening torque: 1.5 Nm \pm10%</p>  <p>xx190000076</p> <p>xx190000075</p>

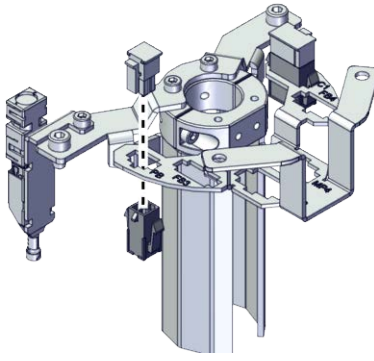

Reconnecting the connector for PB

	Action	Note
1	<p>For robots with protection type Clean Room:</p> <p>Clean the joints that have been opened and wipe the parts free from particles with spirit on a lint free. See Cut the paint or surface on the robot before replacing parts on page 118</p> <p> Note</p> <p>After all repair work, wipe the Clean Room robot free from particles with spirit on a lint free cloth.</p>	

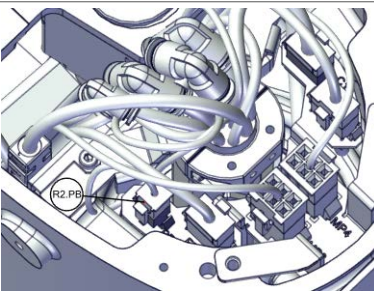
Continues on next page

	Action	Note
2	<p>Insert the female head of the PB connector to the bracket accordingly.</p> <p> Tip</p> <p>The mistake proofing measure has been applied to the connectors, the connectors may be damaged if excessive force is used.</p> <p> Note</p> <p>The harness are not visible due to the cleanness requirements of the illustration. They are still existing inside the cable ferrule in the actual situation.</p>	 <p>xx1900000069</p>
3	<p>Reconnect the connector.</p> <ul style="list-style-type: none"> • R2.PB <p> Tip</p> <p>See the number markings on the connectors for help to find the corresponding connector.</p>	 <p>xx1900000068</p>

Reconnecting the air hoses, CP/CS cabling and Ethernet cabling (if equipped)







	Action	Note
1	<p>For robots with protection type Clean Room: Clean the joints that have been opened and wipe the parts free from particles with spirit on a lint free. See Cut the paint or surface on the robot before replacing parts on page 118</p> <p> Note</p> <p>After all repair work, wipe the Clean Room robot free from particles with spirit on a lint free cloth.</p>	
2	<p>Route the air hoses on the process hub behind the protected bracket.</p> <p> CAUTION</p> <p>Correct cable routing is highly important. If the cables are routed and secured incorrectly the cables can be damaged.</p>	

Continues on next page

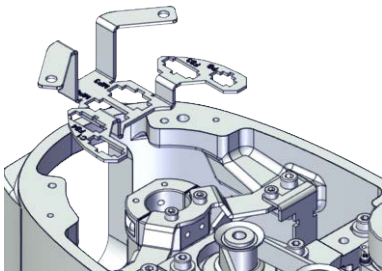
5 Repair

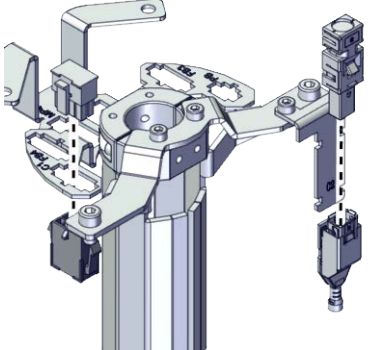

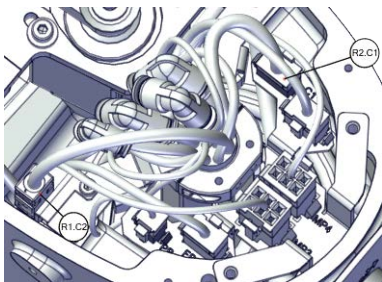

5.3.2 Replacing the internal harness

Continued

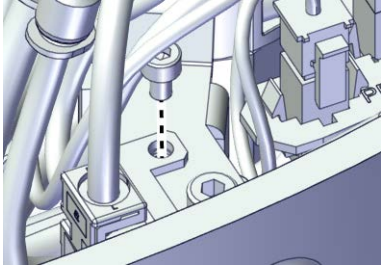

	Action	Note
3	<p>Refit the bracket to the outer arm without screws.</p> <p> Note</p> <p>The harness are not visible due to the cleanness requirements of the illustration. They are still existing inside the cable ferrule in the actual situation.</p>	 <p>xx1900000073</p>
4	<p>Insert the female head of the C1 cabling connector to the bracket accordingly.</p> <p> Tip</p> <p>The mistake proofing measure has been applied to the connectors, the connectors may be damaged if excessive force is used.</p>	 <p>xx1900000071</p>
5	<p>For robots with C1 cabling</p> <p>Reconnect the connector.</p> <ul style="list-style-type: none"> • R2.C1 <p> Tip</p> <p>See the number markings on the air hoses for help to find the corresponding air hoses. The air hoses with the same number connect to the same L-shaped connector.</p> <p> Note</p> <p>The harness are not visible due to the cleanness requirements of the illustration. They are still existing inside the cable ferrule in the actual situation.</p>	 <p>xx1900000070</p>
6	<p>For robots with C2 cabling</p> <p>Reconnect the connector.</p> <ul style="list-style-type: none"> • R1.C2 <p> Tip</p> <p>See the number markings on the air hoses for help to find the corresponding air hoses. The air hoses with the same number connect to the same L-shaped connector.</p>	
7	<p>Secure the C2 cabling to the C2 bracket with the cable straps.</p>	

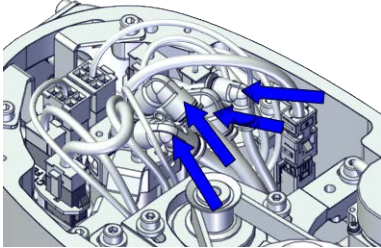
Continues on next page

5.3.2 Replacing the internal harness
Continued

	Action	Note
8	Secure the C2 bracket to the bracket with screw.	<p>Screws: Hex socket head cap screw M3x5 12.9 Lafre 2C2B/FC6.9 (1 pcs) Tightening torque: 4 Nm ±10%</p>  <p>xx190000098</p>
9	<p>Reconnect the air hoses in a cross pattern with the L-shaped connectors.</p>  Tip See the number markings on the air hoses for help to find the corresponding air hoses. The air hoses with the same number connect to the same Y-shaped connector.	 <p>xx1800002837</p>
10	<p>Route and secure the cabling with cable straps if needed.</p>  CAUTION Correct cable routing is highly important. If the cables are routed and secured incorrectly the cables can be damaged.	

Reconnecting the connectors for axis-3 motor



	Action	Note
1	<p>For robots with protection type Clean Room: Clean the joints that have been opened and wipe the parts free from particles with spirit on a lint free. See Cut the paint or surface on the robot before replacing parts on page 118</p>  Note After all repair work, wipe the Clean Room robot free from particles with spirit on a lint free cloth.	
2	<p>Route the cabling on the axis-3 motor behind the protected bracket to the bracket.</p>  CAUTION Correct cable routing is highly important. If the cables are routed and secured incorrectly the cables can be damaged.	

Continues on next page

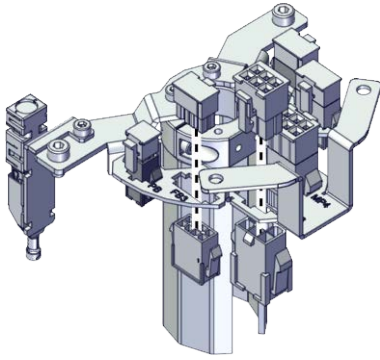

5 Repair

5.3.2 Replacing the internal harness

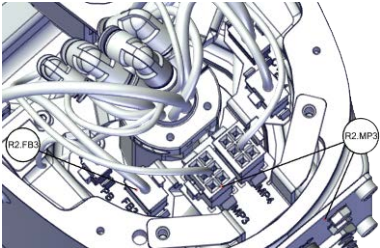

Continued

	Action	Note
3	<p>Insert the female head of the connectors to the bracket accordingly.</p> <p> Tip</p> <p>The mistake proofing measure has been applied to the connectors, the connectors may be damaged if excessive force is used.</p>	 <p>xx1900000064</p>
4	<p>Reconnect the connectors.</p> <ul style="list-style-type: none"> • R2.MP3 • R2.FB3 <p> Tip</p> <p>See the number markings on the connectors for help to find the corresponding connector.</p>	 <p>xx1900000063</p>

Reconnecting the connectors for axis-4 motor

	Action	Note
1	<p>For robots with protection type Clean Room: Clean the joints that have been opened and wipe the parts free from particles with spirit on a lint free. See Cut the paint or surface on the robot before replacing parts on page 118</p> <p> Note</p> <p>After all repair work, wipe the Clean Room robot free from particles with spirit on a lint free cloth.</p>	
2	<p>Route the cabling on the axis-4 motor behind the protected bracket to the bracket.</p> <p> CAUTION</p> <p>Correct cable routing is highly important. If the cables are routed and secured incorrectly the cables can be damaged.</p>	

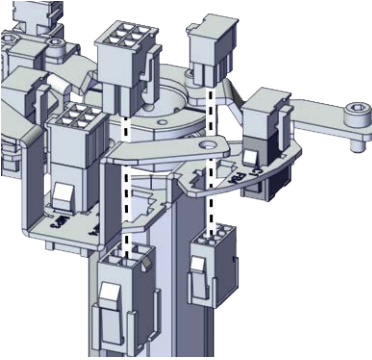
Continues on next page

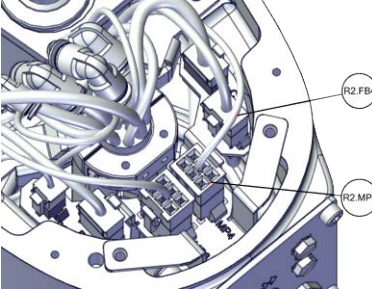
	Action	Note
	<p>Insert the female head of the connectors to the bracket accordingly.</p> <p> Tip</p> <p>The mistake proofing measure has been applied to the connectors, the connectors may be damaged if excessive force is used.</p>	 <p>xx1900000066</p>
3	<p>Reconnect the connectors.</p> <ul style="list-style-type: none"> • R2.MP4 • R2.FB4 <p> Tip</p> <p>See the number markings on the connectors for help to find the corresponding connector.</p>	 <p>xx1900000065</p>

Refitting the bracket for the process hub

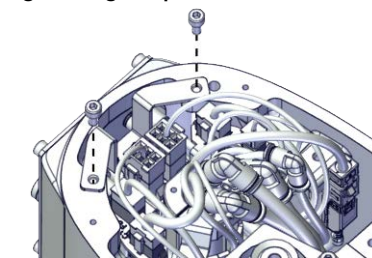
	Action	Note
1	<p>For robots with protection type Clean Room: Clean the joints that have been opened and wipe the parts free from particles with spirit on a lint free. See Cut the paint or surface on the robot before replacing parts on page 118</p> <p> Note</p> <p>After all repair work, wipe the Clean Room robot free from particles with spirit on a lint free cloth.</p>	
2	<p>Secure the bracket with screws.</p>	<p>Screws: Hex socket head cap screw M4x8 12.9 Lafre 2C2B/FC6.9 (2 pcs) Tightening torque: 4 Nm ±10%</p>  <p>xx1800002839</p>



Continues on next page

5 Repair

5.3.2 Replacing the internal harness

Continued

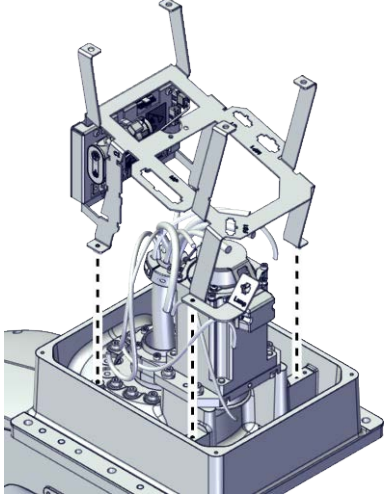
Refitting the bracket

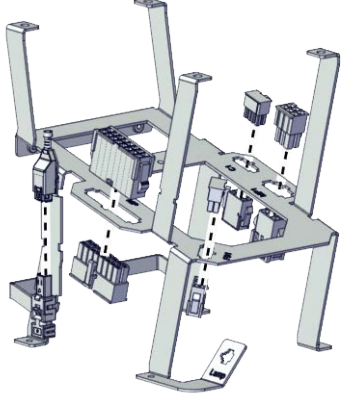
	Action	Note
1	<p>For robots with protection type Clean Room: Clean the joints that have been opened and wipe the parts free from particles with spirit on a lint free. See Cut the paint or surface on the robot before replacing parts on page 118</p> <p> Note</p> <p>After all repair work, wipe the Clean Room robot free from particles with spirit on a lint free cloth.</p>	
2	<p>Refit the bracket and secure with the screws.</p>	<p>Screws: Hex socket head cap screw M3x8 12.9 Lafre 2C2B/FC6.9 (4 pcs) Tightening torque: 1.5 Nm \pm10%</p>  <p>xx1800002869</p>
3	<p>Insert the female head of the connectors to the bracket accordingly.</p> <p> Tip</p> <p>The mistake proofing measure has been applied to the connectors, the connectors may be damaged if excessive force is used.</p>	 <p>xx1900000081</p>

Continues on next page

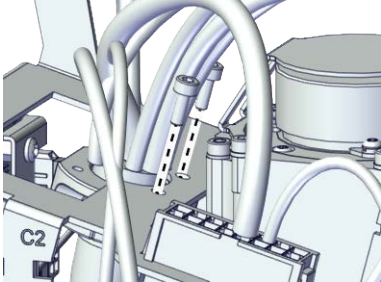
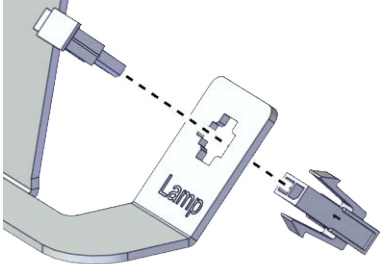
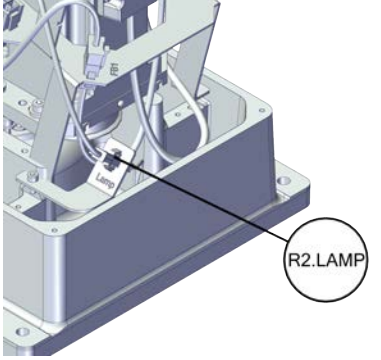
	Action	Note
4	Secure the cable ferrule to the bracket with the screws.	<p>Screws: Hex socket head cap screw M3x5 12.9 Lafre 2C2B/FC6.9 (2 pcs) Tightening torque: 1.5 Nm ±10%</p>  <p>xx190000080</p>
5	Reconnect the lamp connector on the bracket.	 <p>xx190000079</p>  <p>xx1800002867</p>

Refitting the base harness

	Action	Note
1	<p>For robots with protection type Clean Room: Clean the joints that have been opened and wipe the parts free from particles with spirit on a lint free. See Cut the paint or surface on the robot before replacing parts on page 118</p> <p> Note</p> <p>After all repair work, wipe the Clean Room robot free from particles with spirit on a lint free cloth.</p>	

Continues on next page



5 Repair

5.3.2 Replacing the internal harness

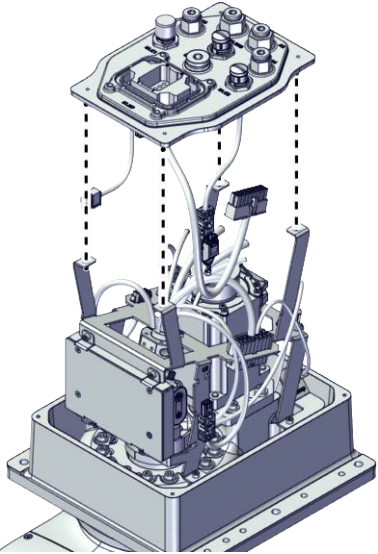
Continued

	Action	Note
2	Refit the base harness to the bracket.	 <p data-bbox="1031 869 1136 887">xx1800002834</p>

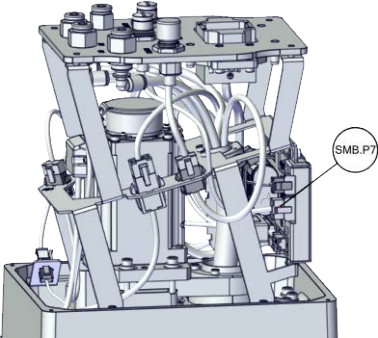

Reconnecting the SMB cabling

	Action	Note
1	 <p data-bbox="571 1070 1002 1102">ELECTROSTATIC DISCHARGE (ESD)</p> <p data-bbox="485 1137 1018 1218">The unit is sensitive to ESD. Before handling the unit read the safety information in section The unit is sensitive to ESD on page 45.</p>	
2	<p data-bbox="485 1254 1018 1397">For robots with protection type Clean Room: Clean the joints that have been opened and wipe the parts free from particles with spirit on a lint free. See Cut the paint or surface on the robot before replacing parts on page 118</p> <p data-bbox="485 1415 542 1469"> Note</p> <p data-bbox="485 1487 1018 1541">After all repair work, wipe the Clean Room robot free from particles with spirit on a lint free cloth.</p>	
3	<p data-bbox="485 1572 778 1603">Reconnect the connectors.</p> <ul data-bbox="517 1603 644 1657" style="list-style-type: none"> • SMB.P7 • SMB.J1 <p data-bbox="485 1675 555 1747"> Tip</p> <p data-bbox="485 1765 1018 1818">See the number markings on the connectors for help to find the corresponding connector.</p>	 <p data-bbox="1031 1917 1136 1935">xx1800002833</p>

Continues on next page

	Action	Note
4	<p>Route and secure the cabling with cable straps if needed.</p> <p> CAUTION</p> <p>Correct cable routing is highly important. If the cables are routed and secured incorrectly the cables can be damaged.</p>	

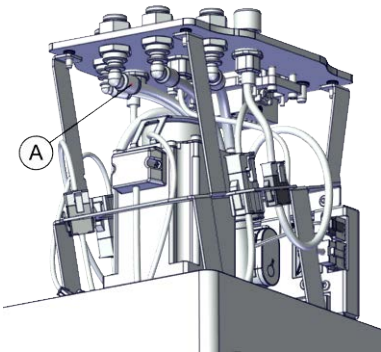

Reconnecting the air hoses, C1 cabling and C2 cabling (if equipped)

	Action	Note		
1	<p>For robots with protection type Clean Room: Clean the joints that have been opened and wipe the parts free from particles with spirit on a lint free. See Cut the paint or surface on the robot before replacing parts on page 118</p> <p> Note</p> <p>After all repair work, wipe the Clean Room robot free from particles with spirit on a lint free cloth.</p>			
2	<p>Reconnect the air hoses in a cross pattern to the L-shaped connectors on the base harness.</p> <p> Tip</p> <p>See the number markings on the air hoses for help to find the corresponding air hoses. The air hoses with the same number connect to the same L-shaped connector.</p> <p> Note</p> <p>Make sure that the air hoses are not bent or broken when you disconnect them.</p>	 <p>xx1800002830</p> <table border="1"> <tr> <td>A</td> <td>Air hoses</td> </tr> </table>	A	Air hoses
A	Air hoses			

5 Repair

5.3.2 Replacing the internal harness

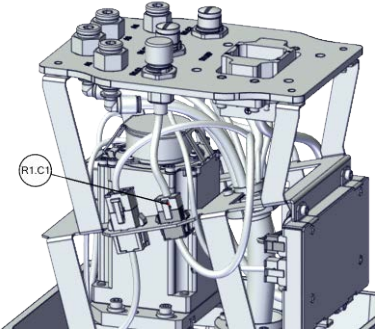
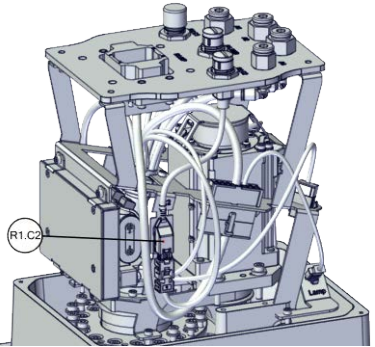

Continued

	Action	Note
3	<p>Reconnect the connectors.</p> <ul style="list-style-type: none"> • R1.C1 • R1.C2 <p> Tip</p> <p>See the number markings on the connectors for help to find the corresponding connector.</p>	 <p>xx1800002831</p>  <p>xx1800002832</p>
4	<p>Route and secure the cabling with cable straps if needed.</p> <p> CAUTION</p> <p>Correct cable routing is highly important. If the cables are routed and secured incorrectly the cables can be damaged.</p>	

Reconnecting the connectors on the base harness

	Action	Note
1	<p>For robots with protection type Clean Room: Clean the joints that have been opened and wipe the parts free from particles with spirit on a lint free. See Cut the paint or surface on the robot before replacing parts on page 118</p> <p> Note</p> <p>After all repair work, wipe the Clean Room robot free from particles with spirit on a lint free cloth.</p>	

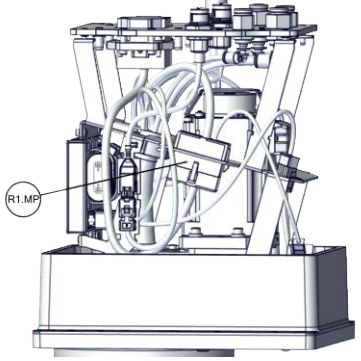
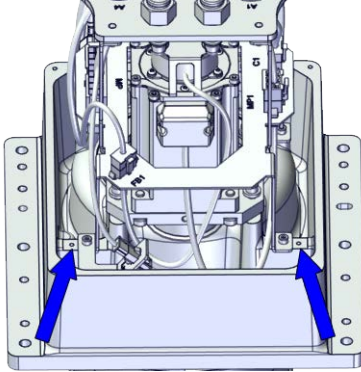
Continues on next page

	Action	Note
2	<p>Reconnect the connector.</p> <ul style="list-style-type: none"> R1.MP <p> Tip</p> <p>See the number markings on the connectors for help to find the corresponding connector.</p>	 <p>xx1800002829</p>
3	<p>Secure the three grounding cables to the bracket with the screw.</p>	<p>Screws: Hex socket head cap screw M3x5 12.9 Lafre 2C2B/FC6.9 (2 pcs)</p> <p>Tightening torque: 1.5 Nm ±10%</p>  <p>xx1900000062</p>
4	<p>Route and secure the cabling with cable straps if needed.</p> <p> CAUTION</p> <p>Correct cable routing is highly important. If the cables are routed and secured incorrectly the cables can be damaged.</p>	

Refitting the base cover



	Action	Note
1	<p>For robots with protection type Clean Room:</p> <p>Clean the joints that have been opened and wipe the parts free from particles with spirit on a lint free. See Cut the paint or surface on the robot before replacing parts on page 118</p> <p> Note</p> <p>After all repair work, wipe the Clean Room robot free from particles with spirit on a lint free cloth.</p>	

Continues on next page

5 Repair

5.3.2 Replacing the internal harness

Continued

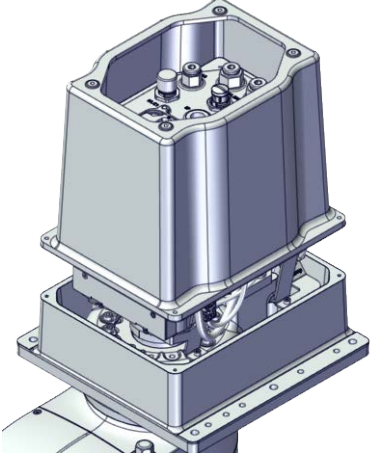
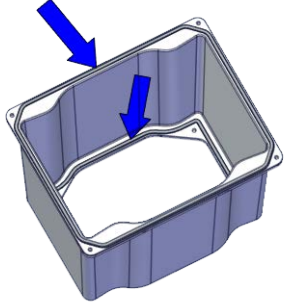
	Action	Note
2	Apply grease to the internal harness, cover all moving area of the harness.	
3	Apply grease to the covers that have contacting area with the harness.	
4	<p>Refit the base cover.</p> <p> Note</p> <p>For robots with protection class IP54 (option 3350-540)</p> <p>For robots with protection type Clean Room (option 3351-1)</p> <p>Check the gasket for the base and the gasket for the base cover before refitting the base cover.</p> <p> Tip</p> <p>Replace the gasket if needed.</p>	 <p>xx1800002828</p> <p>For robots with protection class IP54 (option 3350-540)</p> <p>For robots with protection type Clean Room (option 3351-1)</p>  <p>xx1900001635</p>

Continues on next page

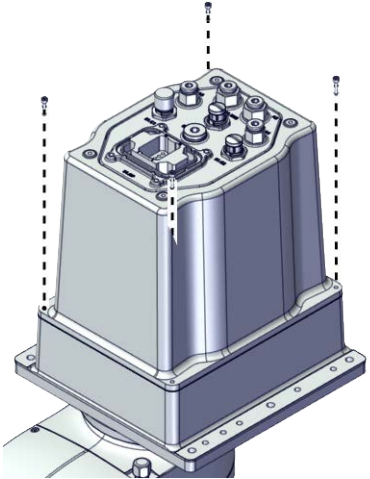
	Action	Note
5	Secure the base cover to the base with the screws.	<p>Screws: Hex socket head cap screw M3x12 12.9 Lafre 2C2B/FC6.9 (4 pcs) Tightening torque: 1.2 Nm \pm10%</p>  <p>xx1800002827</p>

Continues on next page

5 Repair

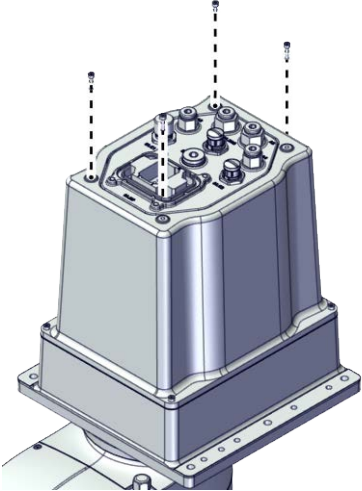
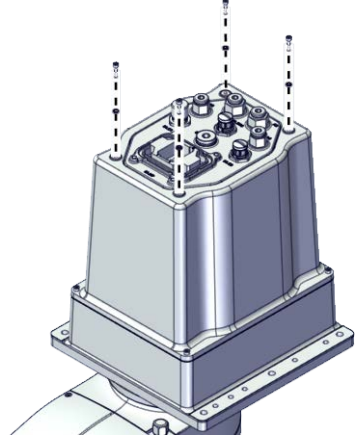

5.3.2 Replacing the internal harness

Continued

	Action	Note
6	<p>Secure the base harness to the base cover with the screws.</p> <p> Note</p> <p>For robots with protection class IP54 (option 3350-540)</p> <p>For robots with protection type Clean Room (option 3351-1)</p> <p>Refit the extra sealing washers on the base cover to the base harness.</p>	<p>For robots with protection class IP30 (option 3350-300)</p> <p>Screws: Hex socket head cap screw M3x12 12.9 Lafre 2C2B/FC6.9 (4 pcs)</p> <p>Tightening torque: 1.2 Nm \pm10%</p>  <p>xx1800002826</p> <p>For robots with protection class IP54 (option 3350-540)</p> <p>For robots with protection type Clean Room (option 3351-1)</p> <p>Screws: Hex socket head cap screw M3x12 12.9 Lafre 2C2B/FC6.9 (4 pcs)</p> <p>Washers: Sealing washer M3 (4 pcs)</p> <p>Tightening torque: 1.2 Nm \pm10%</p>  <p>xx1900001634</p>

Continues on next page

Refitting the casting cover of the inner arm

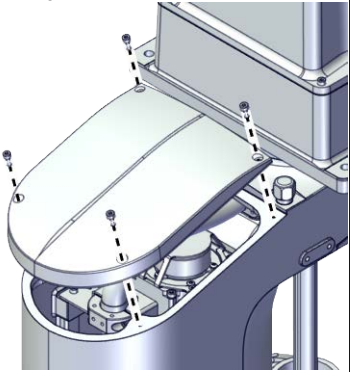
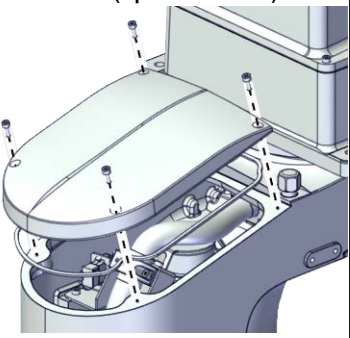
	Action	Note
1	<p>For robots with protection type Clean Room: Clean the joints that have been opened and wipe the parts free from particles with spirit on a lint free. See Cut the paint or surface on the robot before replacing parts on page 118</p> <p> Note</p> <p>After all repair work, wipe the Clean Room robot free from particles with spirit on a lint free cloth.</p>	
2	<p>Refit the casting cover.</p> <p> Note</p> <p>For robots with protection class IP54 (option 3350-540)</p> <p>For robots with protection type Clean Room (option 3351-1)</p> <p>Check the gasket for the casting cover before refitting the base cover.</p> <p> Tip</p> <p>Replace the gasket if needed.</p>	<p>Screw: Hex socket head cap screw M3x8 12.9 Lafre 2C2B/FC6.9 (4 pcs)</p> <p>Tightening torque: 1.2 Nm ±10%</p> <p>For robots with protection class IP30 (option 3350-300)</p>  <p>xx1800002873</p>
3	<p>Refit the screws.</p>	<p>For robots with protection class IP54 (option 3350-540)</p> <p>For robots with protection type Clean Room (option 3351-1)</p>  <p>xx1900001637</p>



Continues on next page

5 Repair

5.3.2 Replacing the internal harness

Continued

Refitting the cover of the inner arm

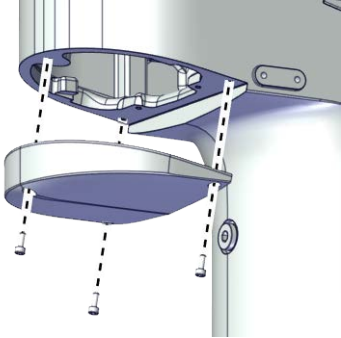
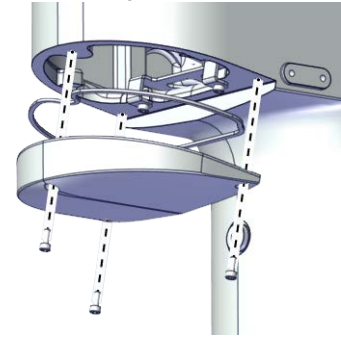
	Action	Note
1	<p>For robots with protection type Clean Room: Clean the joints that have been opened and wipe the parts free from particles with spirit on a lint free. See Cut the paint or surface on the robot before replacing parts on page 118</p> <p> Note</p> <p>After all repair work, wipe the Clean Room robot free from particles with spirit on a lint free cloth.</p>	
2	<p>Refit the cover.</p> <p> Note</p> <p>For robots with protection class IP54 (option 3350-540) For robots with protection type Clean Room (option 3351-1)</p> <p>Check the gasket for the cover before refitting the base cover.</p> <p> Tip</p> <p>Replace the gasket if needed.</p>	<p>Screw: Hex socket head cap screw M3x8 12.9 Lafre 2C2B/FC6.9 (3 pcs) Tightening torque: 1.2 Nm \pm10%</p> <p>For robots with protection class IP30 (option 3350-300)</p> 
3	<p>Refit the screws.</p>	<p>xx1800002899</p> <p>For robots with protection class IP54 (option 3350-540) For robots with protection type Clean Room (option 3351-1)</p>  <p>xx1900001636</p>

Continues on next page

Refitting the cover of the outer arm



	Action	Note
1	<p>For robots with protection type Clean Room: Clean the joints that have been opened and wipe the parts free from particles with spirit on a lint free. See Cut the paint or surface on the robot before replacing parts on page 118</p> <p> Note</p> <p>After all repair work, wipe the Clean Room robot free from particles with spirit on a lint free cloth.</p>	

Continues on next page

5 Repair

5.3.2 Replacing the internal harness

Continued

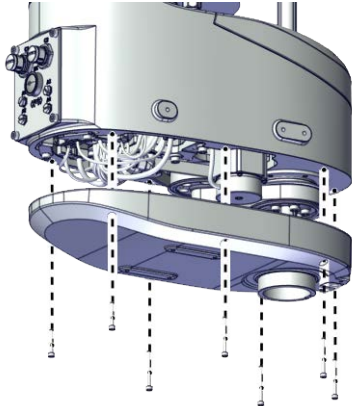
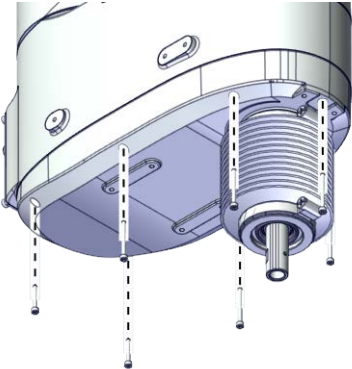
	Action	Note
2	<p>Refit the cover.</p> <p> Note</p> <p>For robots with protection class IP54 (option 3350-540)</p> <p>For robots with protection type Clean Room (option 3351-1)</p> <p>Refit the cover with bellow and housing.</p> <p>Check the gasket on the outer arm cover.</p> <p> Tip</p> <p>Replace the gasket if needed.</p>	<p>For IRB 910INV-3/0.35:</p> <p>Screw: Hex socket head cap screw M3x20 12.9 Lafre 2C2B/FC6.9 (2 pcs)</p> <p>Hex socket head cap screw M3x30 12.9 Lafre 2C2B/FC6.9 (5 pcs)</p> <p>Tightening torque: 1.2 Nm ±10%</p> <p>For IRB 910INV-6/0.55:</p> <p>Screw: Hex socket head cap screw M3x20 12.9 Lafre 2C2B/FC6.9 (2 pcs)</p> <p>Hex socket head cap screw M3x30 12.9 Lafre 2C2B/FC6.9 (7 pcs)</p> <p>Tightening torque: 1.2 Nm ±10%</p> <p>For robots with protection class IP30 (option 3350-300)</p>
3	<p>Refit the screws.</p>	 <p>xx1800002836</p> <p>For robots with protection class IP54 (option 3350-540)</p> <p>For robots with protection type Clean Room (option 3351-1)</p>  <p>xx1900001631</p>

Continues on next page

Refitting the lower cover

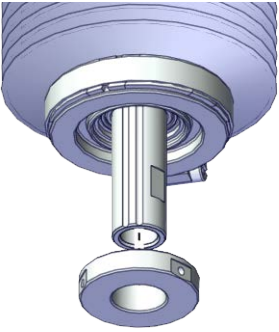
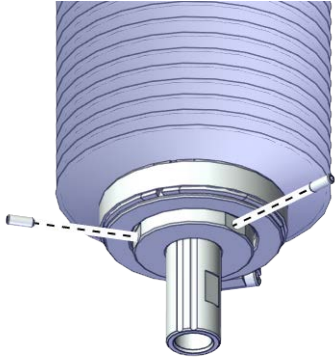
	Action	Note
1	<p>For robots with protection type Clean Room: Clean the joints that have been opened and wipe the parts free from particles with spirit on a lint free. See Cut the paint or surface on the robot before replacing parts on page 118</p> <p> Note</p> <p>After all repair work, wipe the Clean Room robot free from particles with spirit on a lint free cloth.</p>	
2	<p>For robots with protection class IP54 (option 3350-540) For robots with protection type Clean Room (option 3351-1) Refit the lower cover to the ball screw.</p>	 <p>xx1900001607</p>
3	<p>For robots with protection class IP54 (option 3350-540) For robots with protection type Clean Room (option 3351-1) Refit the locking screws.</p>	<p>Screws: Hexagon socket set screws with flat point, ISO 4026 stainless steel M3x8 (2 pcs) Tightening torque: 0.6 Nm ±10%</p>  <p>xx1900001606</p>



Continues on next page

5 Repair

5.3.2 Replacing the internal harness

Continued

Concluding procedure

	Action	Note
1	<p>For robots with protection type Clean Room: Seal and paint the joints that have been opened. See Cut the paint or surface on the robot before replacing parts on page 118</p> <p> Note</p> <p>After all repair work, wipe the Clean Room robot free from particles with spirit on a lint free cloth.</p>	
2	Recalibrate the robot.	Calibration is detailed in section Calibration on page 771 .
3	<p> DANGER</p> <p>Make sure all safety requirements are met when performing the first test run. See Test run after installation, maintenance, or repair on page 56.</p>	

5.3.3 Replacing the process hub

Location of the process hub

The process hub is located as shown in the figure.

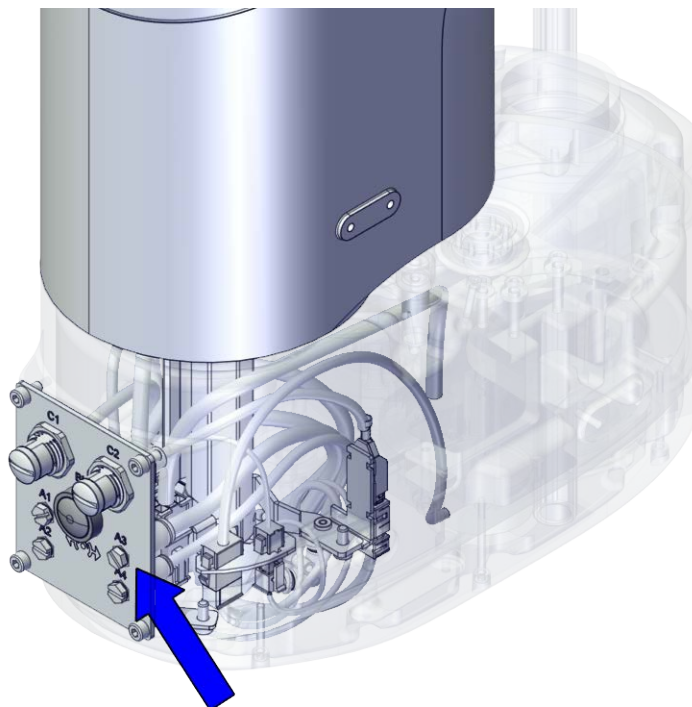

xx1800002835

Required spare parts



Note

The spare part numbers that are listed in the table can be out of date. See the latest spare parts of the IRB 910INV via myABB Business Portal, www.abb.com/myABB.

Spare part	Article number	Note
Process hub, B	3HAC063756-005	
Process hub, B+C1+A	3HAC063756-004	
Process hub, B+C1+C2+A	3HAC063756-001	
Outer arm cover, 350 mm	3HAC073058-001	
Outer arm cover, 550 mm	3HAC073066-001	
Outer arm cover, 350 mm, Clean Room	3HAC073230-001	Used with protection type Clean Room.
Outer arm cove, 550 mm, Clean Room	3HAC073234-001	Used with protection type Clean Room.
Gasket, cover, 350 mm	3HAC066920-001	Replace if damaged.
Gasket, cover, 550 mm	3HAC066921-001	Replace if damaged.

Continues on next page

5 Repair

5.3.3 Replacing the process hub

Continued

Spare part	Article number	Note
Gasket, Process Hub	3HAC061872-001	Replace if damaged.

Required tools and equipment

Equipment	Article number	Note
Standard toolkit	-	Content is defined in section Standard toolkit on page 840 .
Calibration tool box, Axis Calibration	3HAC074119-001	Delivered as a set of calibration tools. Required if Axis Calibration is the valid calibration method for the robot. ⁱ

ⁱ The robot is calibrated by either manual calibration or Axis Calibration at ABB factory before delivery. Always use the same calibration method as used at the factory.

Information about valid calibration method is found on the calibration label or in the calibration menu on the FlexPendant.

If no data is found related to standard calibration, manual calibration is used as default.

Required consumables

Consumable	Article number	Note
Cable straps	-	
Grease	3HAC029132-001	FM 222 Used to lubricate the cable harness.

Deciding calibration routine

Decide which calibration routine to be used, based on the information in the table. Depending on which routine is chosen, action might be required prior to beginning the repair work of the robot, see the table.

	Action	Note
1	Decide which calibration routine to use for calibrating the robot. <ul style="list-style-type: none"> Reference calibration. External cable packages (DressPack) and tools can stay fitted on the robot. Fine calibration. All external cable packages (DressPack) and tools must be removed from the robot. 	
	<p>If the robot is to be calibrated with reference calibration:</p> <p>Find previous reference values for the axis or create new reference values. These values are to be used after the repair procedure is completed, for calibration of the robot.</p> <p>If no previous reference values exist, and no new reference values can be created, then reference calibration is not possible.</p>	<p>Follow the instructions given in the reference calibration routine on the FlexPendant to create reference values.</p> <p>Creating new values requires possibility to move the robot.</p> <p>Read more about reference calibration for Axis Calibration in Reference calibration routine on page 798.</p>



Continues on next page

Action	Note
<p>If the robot is to be calibrated with fine calibration: Remove all external cable packages (DressPack) and tools from the robot.</p>	

Removing the process hub

Use these procedures to remove the process hub.

Preparations before removing the process hub

Action	Note
1	Decide which calibration routine to use, and take actions accordingly prior to beginning the repair procedure.
2	Jog all axes to zero position.
3	 DANGER Turn off all: <ul style="list-style-type: none"> • electric power supply • hydraulic pressure supply • air pressure supply to the robot, before entering the safeguarded space.
4	 CAUTION For robots with protection type Clean Room Always cut the paint with a knife and grind the paint edge when disassembling parts of the robot! See Cut the paint or surface on the robot before replacing parts on page 118.

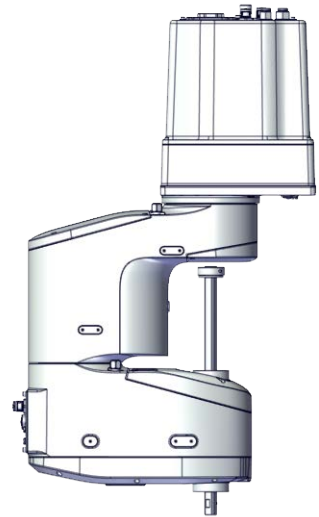



Continues on next page

5 Repair

5.3.3 Replacing the process hub

Continued



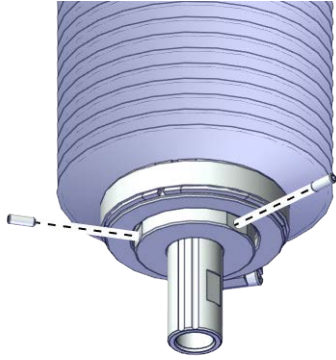
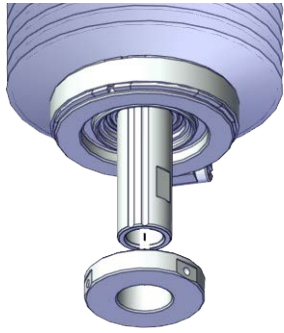

Removing the lower cover

	Action	Note
1	 DANGER Make sure that all supplies for electrical power, hydraulic pressure, and air pressure are turned off.	
2	 CAUTION For robots with protection type Clean Room Always cut the paint with a knife and grind the paint edge when disassembling parts of the robot! See Cut the paint or surface on the robot before replacing parts on page 118 .	
3	For robots with protection class IP54 (option 3350-540) For robots with protection type Clean Room (option 3351-1) Loose the locking screws.	 <small>xx1900001606</small>
4	For robots with protection class IP54 (option 3350-540) For robots with protection type Clean Room (option 3351-1) Remove the lower cover from the ball screw.	 <small>xx1900001607</small>

Removing the cover of the outer arm

	Action	Note
1	 DANGER Make sure that all supplies for electrical power, hydraulic pressure, and air pressure are turned off.	

Continues on next page

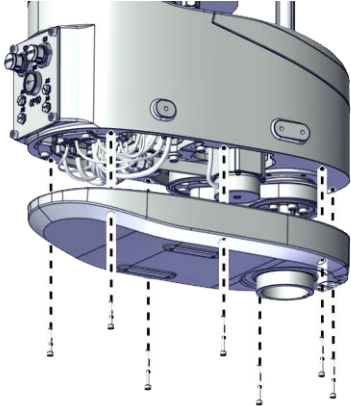
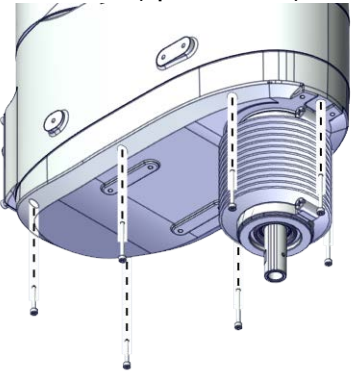
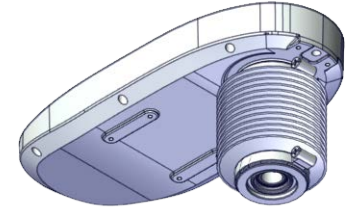
	Action	Note
2	<p> CAUTION</p> <p>For robots with protection type Clean Room Always cut the paint with a knife and grind the paint edge when disassembling parts of the robot! See <i>Cut the paint or surface on the robot before replacing parts on page 118.</i></p>	
3	<p>Remove the screws on the cover of the outer arm and remove the cover.</p> <p> Note</p> <p>For robots with protection class IP54 (option 3350-540) For robots with protection type Clean Room (option 3351-1) Remove the cover with bellow and housing.</p> <p> Note</p> <p>The bellow does not need to be removed separately.</p> <p> CAUTION</p> <p>There is a gasket in the cover. Be careful when removing the cover with bellow and housing.</p> <p> Tip</p> <p>Check the gasket and replace it if needed.</p>	<p>For robots with protection class IP30 (option 3350-300)</p>  <p>xx1800002836</p> <p>For robots with protection class IP54 (option 3350-540) For robots with protection type Clean Room (option 3351-1)</p>  <p>xx1900001631</p>  <p>xx1900001632</p>



Continues on next page

5 Repair



5.3.3 Replacing the process hub

Continued

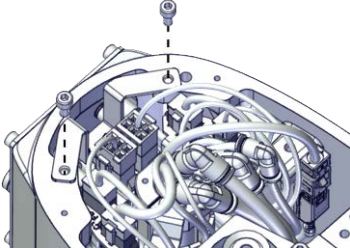
Removing the bracket for the process hub

	Action	Note
1	 DANGER Make sure that all supplies for electrical power, hydraulic pressure, and air pressure are turned off.	
2	 CAUTION For robots with protection type Clean Room Always cut the paint with a knife and grind the paint edge when disassembling parts of the robot! See Cut the paint or surface on the robot before replacing parts on page 118 .	
3	Remove the screws on the bracket and take it out carefully.	 xx1800002839

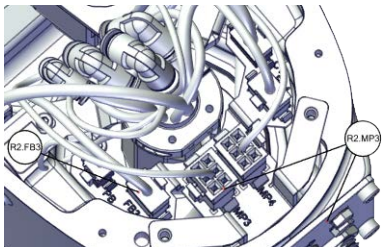

Disconnecting the connectors for axis-3 motor

	Action	Note
1	 DANGER Make sure that all supplies for electrical power, hydraulic pressure, and air pressure are turned off.	
2	 CAUTION For robots with protection type Clean Room Always cut the paint with a knife and grind the paint edge when disassembling parts of the robot! See Cut the paint or surface on the robot before replacing parts on page 118 .	
3	Disconnect the connectors. <ul style="list-style-type: none"> • R2.MP3 • R2.FB3 	 xx1900000063

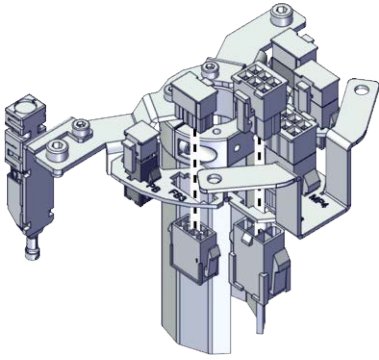
Continues on next page

	Action	Note
4	Snap loose and remove the female head of the connectors from the bracket.	 <p>xx1900000064</p>

Disconnecting the connectors for axis-4 motor

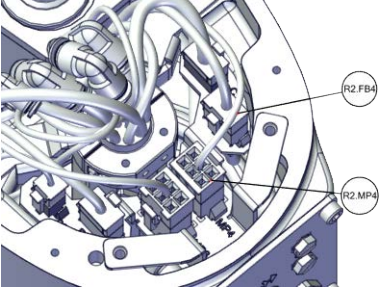
	Action	Note
1	 DANGER Make sure that all supplies for electrical power, hydraulic pressure, and air pressure are turned off.	
2	 CAUTION For robots with protection type Clean Room Always cut the paint with a knife and grind the paint edge when disassembling parts of the robot! See Cut the paint or surface on the robot before replacing parts on page 118.	
3	Disconnect the connectors. <ul style="list-style-type: none"> • R2.MP4 • R2.FB4 	 <p>xx1900000065</p>

Continues on next page



5 Repair

5.3.3 Replacing the process hub

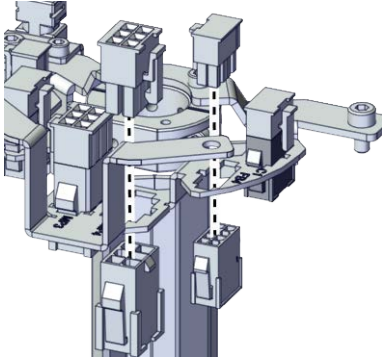
Continued

	Action	Note
4	Snap loose and remove the female head of the connectors from the bracket.	 <p>xx1900000066</p>

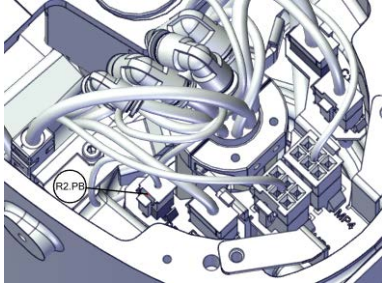

Disconnecting the connector for PB

	Action	Note
1	 DANGER Make sure that all supplies for electrical power, hydraulic pressure, and air pressure are turned off.	
2	 CAUTION For robots with protection type Clean Room Always cut the paint with a knife and grind the paint edge when disassembling parts of the robot! See Cut the paint or surface on the robot before replacing parts on page 118 .	
3	Disconnect the connector. <ul style="list-style-type: none"> R2.PB 	 <p>xx1900000068</p>

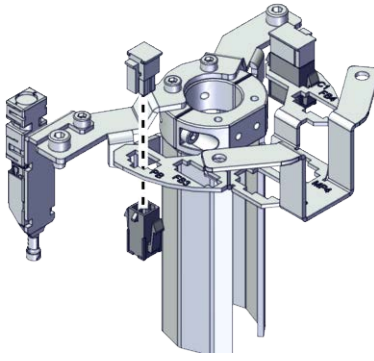
Continues on next page

	Action	Note
4	Snap loose and remove the female head of the connector from the bracket.	 <p>xx190000069</p>

Disconnecting the air hoses, C1 cabling and C2 cabling (if equipped)

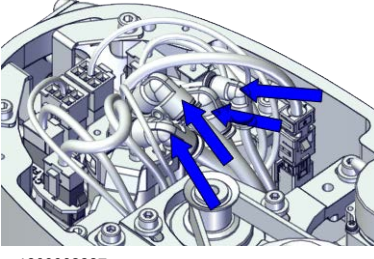



	Action	Note
1	 <p>DANGER</p> <p>Make sure that all supplies for electrical power, hydraulic pressure, and air pressure are turned off.</p>	
2	 <p>CAUTION</p> <p>For robots with protection type Clean Room Always cut the paint with a knife and grind the paint edge when disassembling parts of the robot! See Cut the paint or surface on the robot before replacing parts on page 118.</p>	
3	Disconnect the air hoses from the L-shaped connectors.	 <p>xx1800002837</p>

Continues on next page

5 Repair

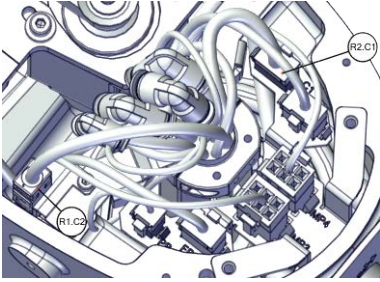

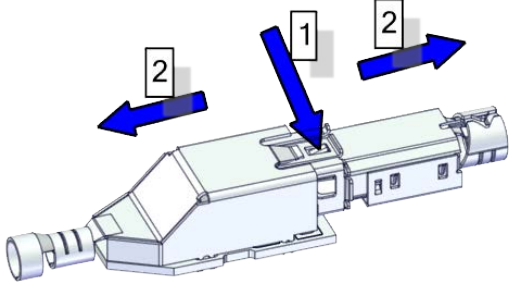
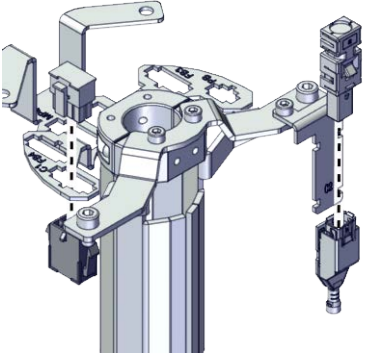
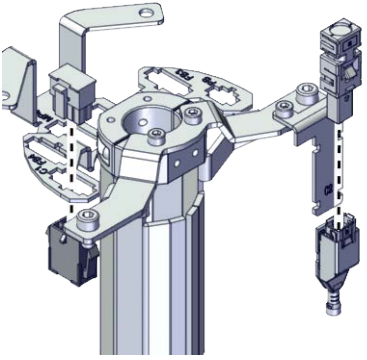

5.3.3 Replacing the process hub

Continued

	Action	Note
4	For robots with C1 cabling Disconnect the connector. <ul style="list-style-type: none">• R2.C1	 xx1900000070
5	For robots with C2 cabling Disconnect the connector. <ul style="list-style-type: none">• R1.C2 <p> Tip</p> <p>Cut the cable straps for the R1.C2 at the same time.</p> <p> Tip</p> <p>Take photos of the connector and cable position before disconnecting them, to have as a reference when reconnecting.</p> <p> Tip</p> <p>The connector clip has to be pressed (1) and pushed forward (2) to separate the R1.C2 (for C2 cabling).</p>  xx1800002943	 xx1900000070
6	Snap loose and remove the female head of the connectors from the bracket.	 xx1900000071

Continues on next page

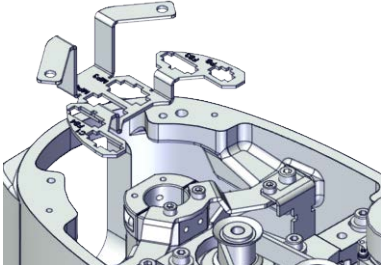
Removing the cable ferrule, bracket and protected bracket

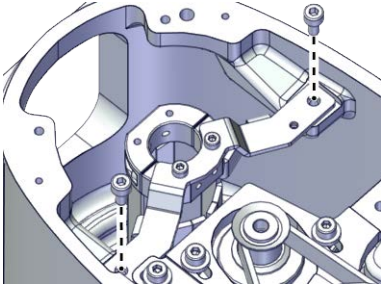

	Action	Note
1	 <p>DANGER</p> <p>Make sure that all supplies for electrical power, hydraulic pressure, and air pressure are turned off.</p>	
2	 <p>CAUTION</p> <p>For robots with protection type Clean Room Always cut the paint with a knife and grind the paint edge when disassembling parts of the robot! See Cut the paint or surface on the robot before replacing parts on page 118.</p>	
3	<p>Take out the bracket from the outer arm.</p>  <p>Note</p> <p>The harness are not visible due to the cleanness requirements of the illustration. They are still existing inside the cable ferrule in the actual situation.</p>	 <p>xx1900000073</p>
4	<p>Remove the screws on the protected bracket.</p>  <p>Note</p> <p>The harness are not visible due to the cleanness requirements of the illustration. They are still existing inside the cable ferrule in the actual situation.</p>	 <p>xx1900000074</p>

Continues on next page

5 Repair

5.3.3 Replacing the process hub

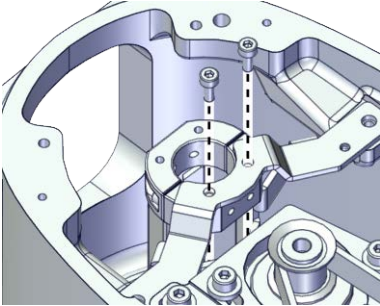
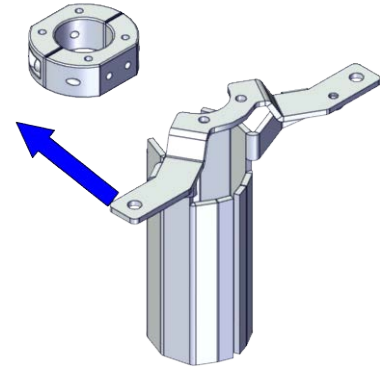

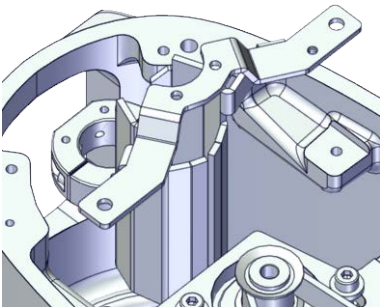
Continued

	Action	Note
5	<p>Remove the screws on the protected bracket to the cable ferrule to release the cable ferrule with cable.</p> <p> Note</p> <p>The harness are not visible due to the cleanness requirements of the illustration. They are still existing inside the cable ferrule in the actual situation.</p>	 <p>xx1900000075</p>  <p>xx1900000076</p>
6	<p>Remove the protected bracket.</p> <p> Tip</p> <p>Pull the protected bracket to the ball screw side to push the cable with the cable ferrule out from the protected bracket.</p> <p> Note</p> <p>The harness are not visible due to the cleanness requirements of the illustration. They are still existing inside the cable ferrule in the actual situation.</p>	 <p>xx1900000078</p>

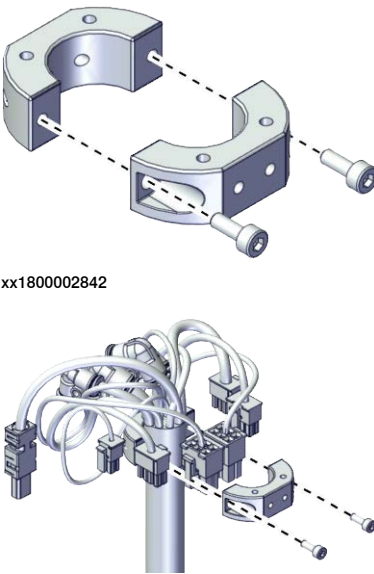
Continues on next page

	Action	Note
7	Remove the screws on the cable ferrule and take the cable ferrule out.	 <p>xx1800002842</p> <p>xx1800002849</p>

Pull out the process hub

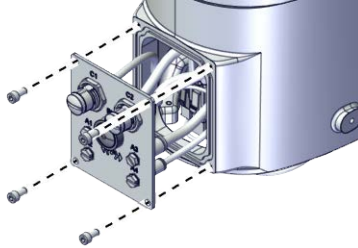
	Action	Note
1	 <p>DANGER</p> <p>Make sure that all supplies for electrical power, hydraulic pressure, and air pressure are turned off.</p>	
2	 <p>CAUTION</p> <p>For robots with protection type Clean Room Always cut the paint with a knife and grind the paint edge when disassembling parts of the robot! See Cut the paint or surface on the robot before replacing parts on page 118.</p>	
3	<p>Remove the screws and carefully pull out the process hub.</p>  <p>CAUTION</p> <p>Be aware of the cabling that is attached to the cover! The cover can not be removed completely until the connectors are disconnected, as shown in following steps.</p>	 <p>xx1800002848</p>

Continues on next page

5 Repair





5.3.3 Replacing the process hub

Continued

Refitting the process hub





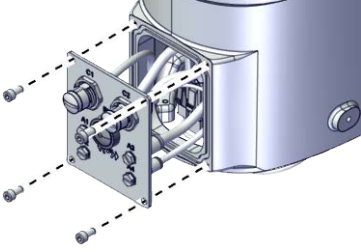
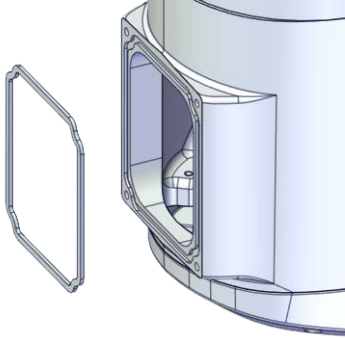

Use these procedures to refit the process hub.

Refitting the process hub

	Action	Note
1	<p>For robots with protection type Clean Room: Clean the joints that have been opened and wipe the parts free from particles with spirit on a lint free. See Cut the paint or surface on the robot before replacing parts on page 118</p> <p> Note</p> <p>After all repair work, wipe the Clean Room robot free from particles with spirit on a lint free cloth.</p>	
2	<p>Refit the process hub to the outer arm and secure it with the screws.</p> <p> Note</p> <p>For robots with protection class IP54 (option 3350-540)</p> <p>For robots with protection type Clean Room (option 3351-1)</p> <p>Check the gasket for the process hub on the outer arm.</p> <p> Tip</p> <p>Replace the gasket if needed.</p> <p> CAUTION</p> <p>Be aware of the cabling that is attached to the cover! The cover can not be removed completely until the connectors are disconnected, as shown in following steps.</p>	<p>Screws: Hex socket head cap screw M4x8 12.9 Lafre 2C2B/FC6.9 (4 pcs) Tightening torque: 4 Nm ±10%</p>  <p>xx1800002848</p> <p>For robots with protection class IP54 (option 3350-540)</p> <p>For robots with protection type Clean Room (option 3351-1)</p>  <p>xx1900001638</p>

Continues on next page

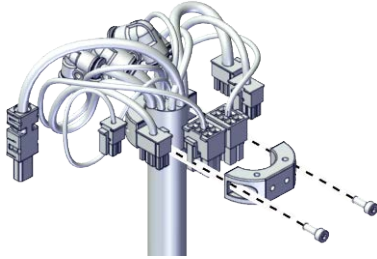
Refitting the cable ferrule and protected bracket

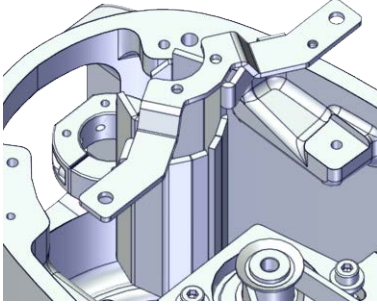

	Action	Note
1	<p>For robots with protection type Clean Room: Clean the joints that have been opened and wipe the parts free from particles with spirit on a lint free. See Cut the paint or surface on the robot before replacing parts on page 118</p> <p> Note</p> <p>After all repair work, wipe the Clean Room robot free from particles with spirit on a lint free cloth.</p>	
2	<p>Lay the internal harness in a natural state without distortion.</p>	
3	<p>Refit the cable ferrule and secure it with the screws.</p> <p> Tip</p> <p>The air hoses should face the process hub side.</p> <p> Tip</p> <p>The position with wrapped tape is the marked position for the cable ferrule.</p> <p> Tip</p> <p>Align all the cable ferrules so that the cable is in a natural bending position to avoid twisting.</p>	<p>Screws: Hex socket head cap screw M3x8 12.9 Lafre 2C2B/FC6.9 (2 pcs) Tightening torque: 1.5 Nm ±10%</p>  <p>xx1800002849</p>
4	<p>Refit the protected bracket.</p> <p> Tip</p> <p>Do not secure it with the screws before the cable ferrule installed well.</p> <p> Note</p> <p>The harness are not visible due to the cleanness requirements of the illustration. They are still existing inside the cable ferrule in the actual situation.</p>	<p>Screws: Hex socket head cap screw M4x8 12.9 Lafre 2C2B/FC6.9 (2 pcs) Tightening torque: 4 Nm ±10%</p>  <p>xx1900000078</p>

Continues on next page



5 Repair

5.3.3 Replacing the process hub

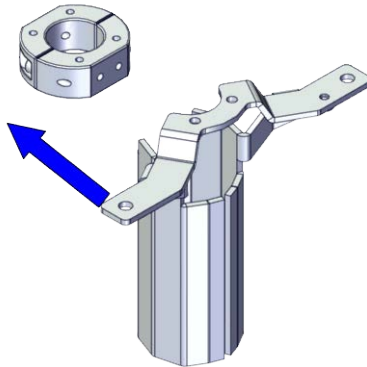
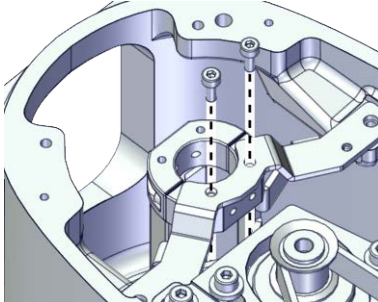





Continued

	Action	Note
5	<p>Secure the cable ferrule to the protected bracket.</p> <p> Tip</p> <p>Align all the cable ferrules so that the cable is in a natural bending position to avoid twisting.</p> <p> Note</p> <p>The harness are not visible due to the cleanliness requirements of the illustration. They are still existing inside the cable ferrule in the actual situation.</p>	<p>Screws: Hex socket head cap screw M3x5 12.9 Lafre 2C2B/FC6.9 (2 pcs)</p> <p>Tightening torque: 1.5 Nm \pm10%</p>  <p>xx190000076</p>  <p>xx190000075</p>

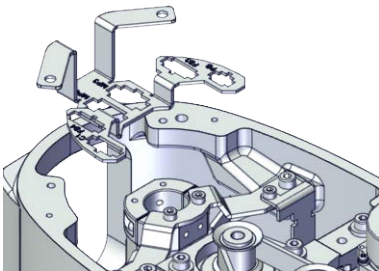
Reconnecting the air hoses, CP/CS cabling and Ethernet cabling (if equipped)

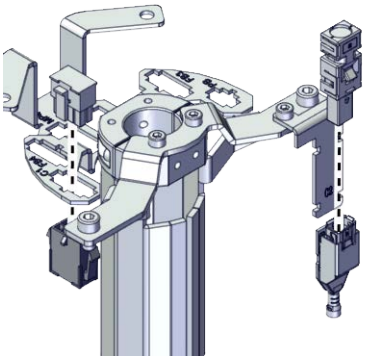
	Action	Note
1	<p>For robots with protection type Clean Room: Clean the joints that have been opened and wipe the parts free from particles with spirit on a lint free. See Cut the paint or surface on the robot before replacing parts on page 118</p> <p> Note</p> <p>After all repair work, wipe the Clean Room robot free from particles with spirit on a lint free cloth.</p>	
2	<p>Route the air hoses on the process hub behind the protected bracket.</p> <p> CAUTION</p> <p>Correct cable routing is highly important. If the cables are routed and secured incorrectly the cables can be damaged.</p>	

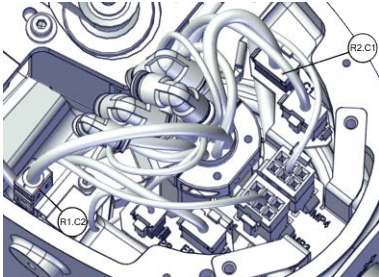
Continues on next page





	Action	Note
3	<p>Refit the bracket to the outer arm without screws.</p> <p> Note</p> <p>The harness are not visible due to the cleanness requirements of the illustration. They are still existing inside the cable ferrule in the actual situation.</p>	 <p>xx1900000073</p>
4	<p>Insert the female head of the C1 cabling connector to the bracket accordingly.</p> <p> Tip</p> <p>The mistake proofing measure has been applied to the connectors, the connectors may be damaged if excessive force is used.</p>	 <p>xx1900000071</p>
5	<p>For robots with C1 cabling</p> <p>Reconnect the connector.</p> <ul style="list-style-type: none"> • R2.C1 <p> Tip</p> <p>See the number markings on the air hoses for help to find the corresponding air hoses. The air hoses with the same number connect to the same L-shaped connector.</p> <p> Note</p> <p>The harness are not visible due to the cleanness requirements of the illustration. They are still existing inside the cable ferrule in the actual situation.</p>	 <p>xx1900000070</p>
6	<p>For robots with C2 cabling</p> <p>Reconnect the connector.</p> <ul style="list-style-type: none"> • R1.C2 <p> Tip</p> <p>See the number markings on the air hoses for help to find the corresponding air hoses. The air hoses with the same number connect to the same L-shaped connector.</p>	
7	<p>Secure the C2 cabling to the C2 bracket with the cable straps.</p>	

Continues on next page

5 Repair

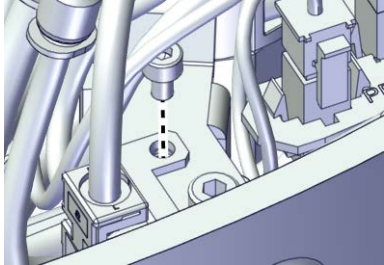
5.3.3 Replacing the process hub

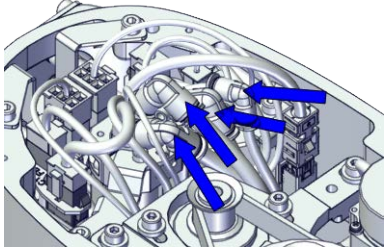



Continued

	Action	Note
8	Secure the C2 bracket to the bracket with screw.	<p>Screws: Hex socket head cap screw M3x5 12.9 Lafre 2C2B/FC6.9 (1 pcs)</p> <p>Tightening torque: 4 Nm \pm10%</p>  <p>xx1900000098</p>
9	<p>Reconnect the air hoses in a cross pattern with the L-shaped connectors.</p> <p> Tip</p> <p>See the number markings on the air hoses for help to find the corresponding air hoses. The air hoses with the same number connect to the same Y-shaped connector.</p>	 <p>xx1800002837</p>
10	<p>Route and secure the cabling with cable straps if needed.</p> <p> CAUTION</p> <p>Correct cable routing is highly important. If the cables are routed and secured incorrectly the cables can be damaged.</p>	

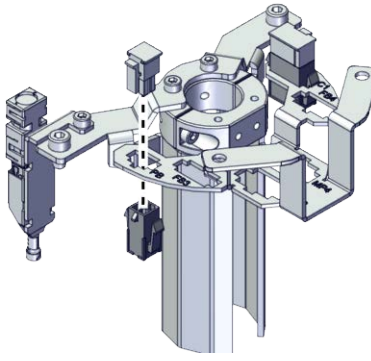

Reconnecting the connector for PB

	Action	Note
1	<p>For robots with protection type Clean Room: Clean the joints that have been opened and wipe the parts free from particles with spirit on a lint free. See Cut the paint or surface on the robot before replacing parts on page 118</p> <p> Note</p> <p>After all repair work, wipe the Clean Room robot free from particles with spirit on a lint free cloth.</p>	

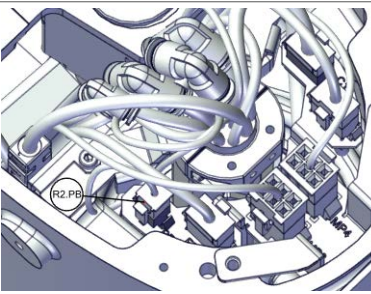
Continues on next page

	Action	Note
2	<p>Insert the female head of the PB connector to the bracket accordingly.</p> <p> Tip</p> <p>The mistake proofing measure has been applied to the connectors, the connectors may be damaged if excessive force is used.</p> <p> Note</p> <p>The harness are not visible due to the cleanness requirements of the illustration. They are still existing inside the cable ferrule in the actual situation.</p>	 <p>xx1900000069</p>
3	<p>Reconnect the connector.</p> <ul style="list-style-type: none"> • R2.PB <p> Tip</p> <p>See the number markings on the connectors for help to find the corresponding connector.</p>	 <p>xx1900000068</p>

Reconnecting the connectors for axis-4 motor



	Action	Note
1	<p>For robots with protection type Clean Room: Clean the joints that have been opened and wipe the parts free from particles with spirit on a lint free. See Cut the paint or surface on the robot before replacing parts on page 118</p> <p> Note</p> <p>After all repair work, wipe the Clean Room robot free from particles with spirit on a lint free cloth.</p>	
2	<p>Route the cabling on the axis-4 motor behind the protected bracket to the bracket.</p> <p> CAUTION</p> <p>Correct cable routing is highly important. If the cables are routed and secured incorrectly the cables can be damaged.</p>	

Continues on next page

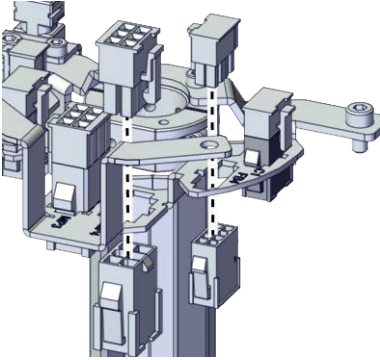

5 Repair

5.3.3 Replacing the process hub

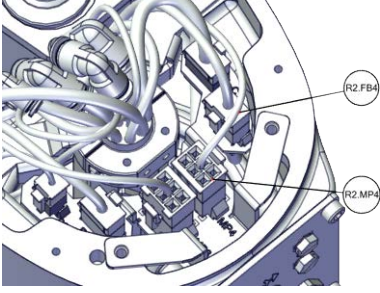

Continued

	Action	Note
	<p>Insert the female head of the connectors to the bracket accordingly.</p> <p> Tip</p> <p>The mistake proofing measure has been applied to the connectors, the connectors may be damaged if excessive force is used.</p>	 <p>xx1900000066</p>
3	<p>Reconnect the connectors.</p> <ul style="list-style-type: none"> • R2.MP4 • R2.FB4 <p> Tip</p> <p>See the number markings on the connectors for help to find the corresponding connector.</p>	 <p>xx1900000065</p>

Reconnecting the connectors for axis-3 motor

	Action	Note
1	<p>For robots with protection type Clean Room: Clean the joints that have been opened and wipe the parts free from particles with spirit on a lint free. See Cut the paint or surface on the robot before replacing parts on page 118</p> <p> Note</p> <p>After all repair work, wipe the Clean Room robot free from particles with spirit on a lint free cloth.</p>	
2	<p>Route the cabling on the axis-3 motor behind the protected bracket to the bracket.</p> <p> CAUTION</p> <p>Correct cable routing is highly important. If the cables are routed and secured incorrectly the cables can be damaged.</p>	

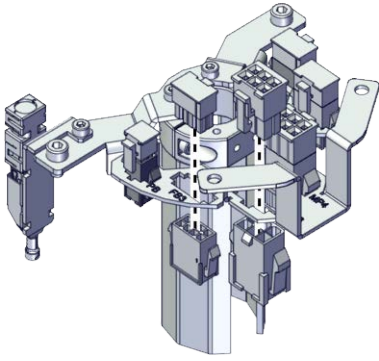
Continues on next page

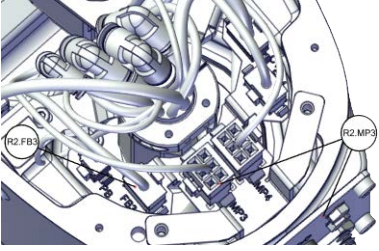
	Action	Note
3	<p>Insert the female head of the connectors to the bracket accordingly.</p> <p> Tip</p> <p>The mistake proofing measure has been applied to the connectors, the connectors may be damaged if excessive force is used.</p>	 <p>xx1900000064</p>
4	<p>Reconnect the connectors.</p> <ul style="list-style-type: none"> • R2.MP3 • R2.FB3 <p> Tip</p> <p>See the number markings on the connectors for help to find the corresponding connector.</p>	 <p>xx1900000063</p>

Refitting the bracket for the process hub

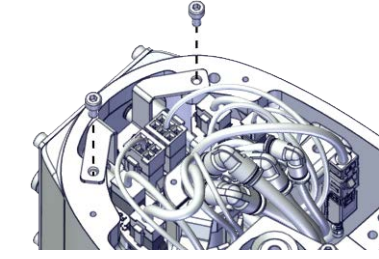
	Action	Note
1	<p>For robots with protection type Clean Room: Clean the joints that have been opened and wipe the parts free from particles with spirit on a lint free. See Cut the paint or surface on the robot before replacing parts on page 118</p> <p> Note</p> <p>After all repair work, wipe the Clean Room robot free from particles with spirit on a lint free cloth.</p>	
2	<p>Secure the bracket with screws.</p>	<p>Screws: Hex socket head cap screw M4x8 12.9 Lafre 2C2B/FC6.9 (2 pcs) Tightening torque: 4 Nm ±10%</p>  <p>xx1800002839</p>

Continues on next page

5 Repair



5.3.3 Replacing the process hub

Continued

Refitting the cover of the outer arm

	Action	Note
1	<p>For robots with protection type Clean Room: Clean the joints that have been opened and wipe the parts free from particles with spirit on a lint free. See Cut the paint or surface on the robot before replacing parts on page 118</p> <p> Note</p> <p>After all repair work, wipe the Clean Room robot free from particles with spirit on a lint free cloth.</p>	

Continues on next page

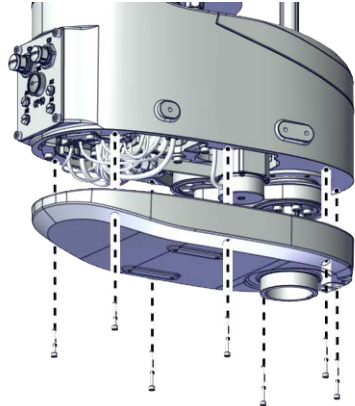
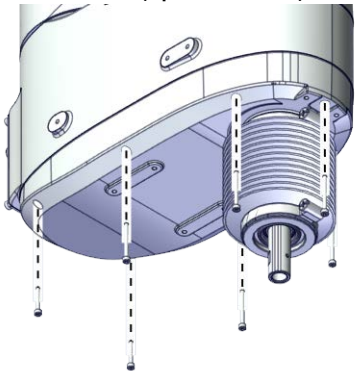
	Action	Note
2	<p>Refit the cover.</p> <p> Note</p> <p>For robots with protection class IP54 (option 3350-540)</p> <p>For robots with protection type Clean Room (option 3351-1)</p> <p>Refit the cover with bellow and housing.</p> <p>Check the gasket on the outer arm cover.</p> <p> Tip</p> <p>Replace the gasket if needed.</p>	<p>For IRB 910INV-3/0.35:</p> <p>Screw: Hex socket head cap screw M3x20 12.9 Lafre 2C2B/FC6.9 (2 pcs)</p> <p>Hex socket head cap screw M3x30 12.9 Lafre 2C2B/FC6.9 (5 pcs)</p> <p>Tightening torque: 1.2 Nm ±10%</p> <p>For IRB 910INV-6/0.55:</p> <p>Screw: Hex socket head cap screw M3x20 12.9 Lafre 2C2B/FC6.9 (2 pcs)</p> <p>Hex socket head cap screw M3x30 12.9 Lafre 2C2B/FC6.9 (7 pcs)</p> <p>Tightening torque: 1.2 Nm ±10%</p> <p>For robots with protection class IP30 (option 3350-300)</p>
3	<p>Refit the screws.</p>	 <p>xx1800002836</p> <p>For robots with protection class IP54 (option 3350-540)</p> <p>For robots with protection type Clean Room (option 3351-1)</p>  <p>xx1900001631</p>

Continues on next page

5 Repair

5.3.3 Replacing the process hub

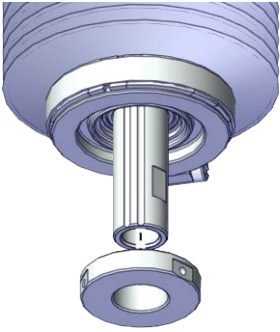
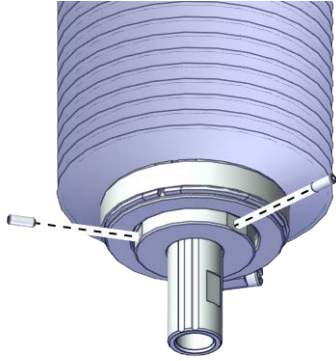

Continued

Refitting the lower cover

	Action	Note
1	<p>For robots with protection type Clean Room: Clean the joints that have been opened and wipe the parts free from particles with spirit on a lint free. See Cut the paint or surface on the robot before replacing parts on page 118</p> <p> Note</p> <p>After all repair work, wipe the Clean Room robot free from particles with spirit on a lint free cloth.</p>	
2	<p>For robots with protection class IP54 (option 3350-540) For robots with protection type Clean Room (option 3351-1) Refit the lower cover to the ball screw.</p>	 <p>xx1900001607</p>
3	<p>For robots with protection class IP54 (option 3350-540) For robots with protection type Clean Room (option 3351-1) Refit the locking screws.</p>	<p>Screws: Hexagon socket set screws with flat point, ISO 4026 stainless steel M3x8 (2 pcs) Tightening torque: 0.6 Nm \pm10%</p>  <p>xx1900001606</p>

Continues on next page

Concluding procedure

	Action	Note
1	<p>For robots with protection type Clean Room: Seal and paint the joints that have been opened. See Cut the paint or surface on the robot before replacing parts on page 118</p> <p> Note</p> <p>After all repair work, wipe the Clean Room robot free from particles with spirit on a lint free cloth.</p>	
2	Recalibrate the robot.	Calibration is detailed in section Calibration on page 771 .
3	<p> DANGER</p> <p>Make sure all safety requirements are met when performing the first test run. See Test run after installation, maintenance, or repair on page 56.</p>	

5 Repair

5.3.4 Replacing the SMB unit and battery unit

5.3.4 Replacing the SMB unit and battery unit

Location of the SMB unit and battery unit

The SMB unit and battery unit are located as shown in the figure.

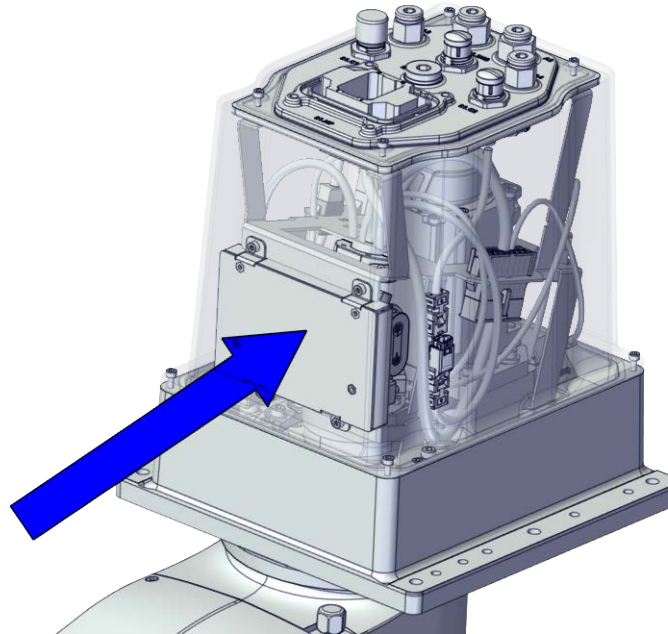

xx1800002844

Required spare parts



Note

The spare part numbers that are listed in the table can be out of date. See the latest spare parts of the IRB 910INV via myABB Business Portal, www.abb.com/myABB.

Spare part	Article number	Note
SMB unit	3HAC063968-001	
Battery unit	3HAC044075-001	Battery includes protection circuits. Only replace with a specified spare part or an ABB-approved equivalent.

Required tools and equipment

Equipment	Article number	Note
Standard toolkit	-	Content is defined in section Standard toolkit on page 840 .

Continues on next page

Equipment	Article number	Note
Calibration tool box, Axis Calibration	3HAC074119-001	Delivered as a set of calibration tools. Required if Axis Calibration is the valid calibration method for the robot. ⁱ

- ⁱ The robot is calibrated by either manual calibration or Axis Calibration at ABB factory before delivery. Always use the same calibration method as used at the factory.
Information about valid calibration method is found on the calibration label or in the calibration menu on the FlexPendant.
If no data is found related to standard calibration, manual calibration is used as default.

Required consumables

Consumable	Article number	Note
Cable straps	-	

Deciding calibration routine

Decide which calibration routine to be used, based on the information in the table. Depending on which routine is chosen, action might be required prior to beginning the repair work of the robot, see the table.

	Action	Note
1	Decide which calibration routine to use for calibrating the robot. <ul style="list-style-type: none"> Reference calibration. External cable packages (DressPack) and tools can stay fitted on the robot. Fine calibration. All external cable packages (DressPack) and tools must be removed from the robot. 	
	If the robot is to be calibrated with reference calibration: Find previous reference values for the axis or create new reference values. These values are to be used after the repair procedure is completed, for calibration of the robot. If no previous reference values exist, and no new reference values can be created, then reference calibration is not possible.	Follow the instructions given in the reference calibration routine on the FlexPendant to create reference values. Creating new values requires possibility to move the robot. Read more about reference calibration for Axis Calibration in Reference calibration routine on page 798 .
	If the robot is to be calibrated with fine calibration: Remove all external cable packages (DressPack) and tools from the robot.	

Removing the SMB unit and battery unit

Use these procedures to remove the SMB unit and battery unit.

Preparations before removing the SMB unit and battery unit



	Action	Note
1	Decide which calibration routine to use, and take actions accordingly prior to beginning the repair procedure.	

Continues on next page

5 Repair

5.3.4 Replacing the SMB unit and battery unit

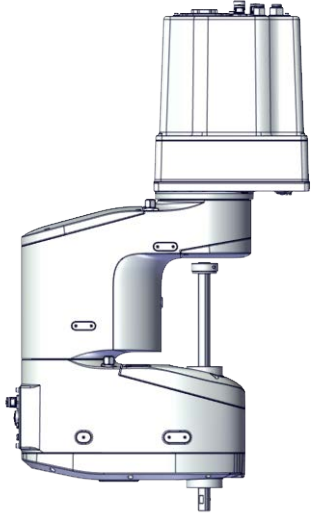

Continued

	Action	Note
2	Jog all axes to zero position.	 <p>xx1800002825</p>
3	 DANGER Turn off all: <ul style="list-style-type: none"> • electric power supply • hydraulic pressure supply • air pressure supply to the robot, before entering the safeguarded space.	
4	 CAUTION For robots with protection type Clean Room Always cut the paint with a knife and grind the paint edge when disassembling parts of the robot! See Cut the paint or surface on the robot before replacing parts on page 118 .	

Removing the base cover

	Action	Note
1	 DANGER Make sure that all supplies for electrical power, hydraulic pressure, and air pressure are turned off.	

Continues on next page

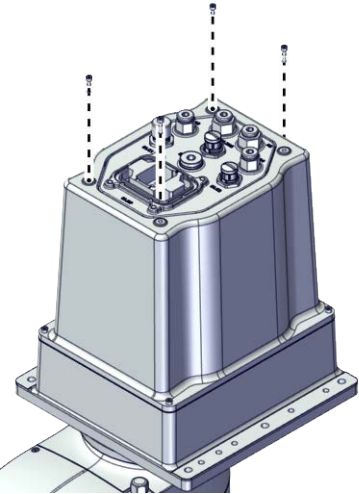
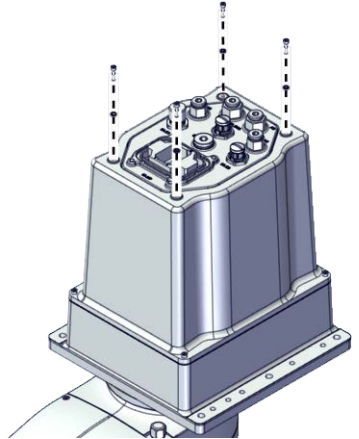
	Action	Note
2	<p> CAUTION</p> <p>For robots with protection type Clean Room Always cut the paint with a knife and grind the paint edge when disassembling parts of the robot! See <i>Cut the paint or surface on the robot before replacing parts on page 118.</i></p>	
3	<p>Remove the screws on the base cover to the base harness.</p> <p> Note</p> <p>For robots with protection class IP54 (option 3350-540) For robots with protection type Clean Room (option 3351-1) Remove the extra sealing washers on the base cover to the base harness.</p>	<p>For robots with protection class IP30 (option 3350-300)</p>  <p>xx1800002826</p> <p>For robots with protection class IP54 (option 3350-540) For robots with protection type Clean Room (option 3351-1)</p>  <p>xx1900001634</p>

Continues on next page



5 Repair

5.3.4 Replacing the SMB unit and battery unit

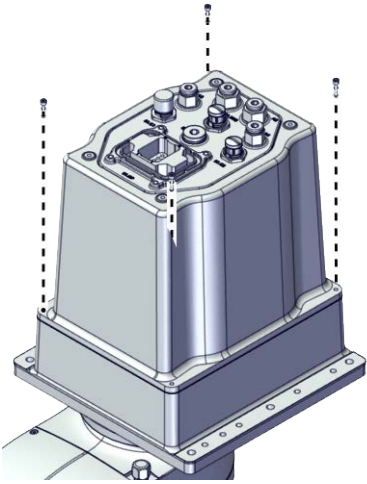
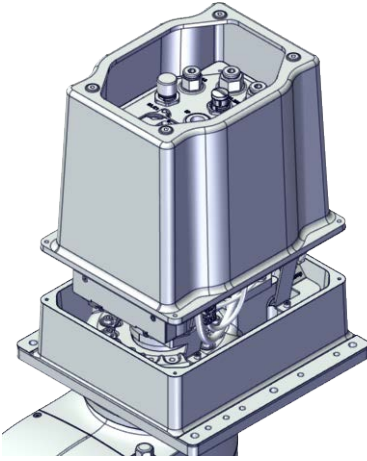

Continued

	Action	Note
4	Remove the screws on the base cover to the base.	 <p>xx1800002827</p>
5	Take the base cover out.	 <p>xx1800002828</p>

Separating the SMB unit and battery unit

	Action	Note
1	 <p>DANGER</p> <p>Make sure that all supplies for electrical power, hydraulic pressure, and air pressure are turned off.</p>	
2	 <p>ELECTROSTATIC DISCHARGE (ESD)</p> <p>The unit is sensitive to ESD. Before handling the unit read the safety information in section The unit is sensitive to ESD on page 45.</p>	

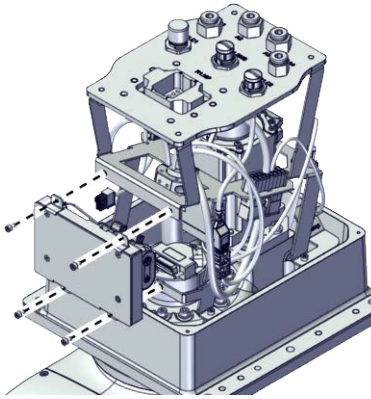
Continues on next page

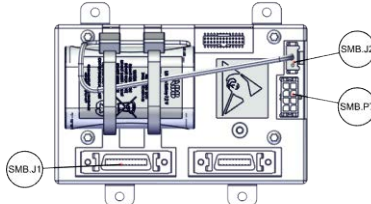
	Action	Note
3	<p> CAUTION</p> <p>For robots with protection type Clean Room Always cut the paint with a knife and grind the paint edge when disassembling parts of the robot! See Cut the paint or surface on the robot before replacing parts on page 118.</p>	
4	<p>Remove the SMB package attachment screws and remove the SMB package from the bracket.</p>	 <p>xx1800002845</p>
5	<p>Disconnect the connectors.</p> <ul style="list-style-type: none"> • SMB.P7 • SMB.J1 • SMB.J2 <p> Tip</p> <p>Take photos of the connector and cable position before disconnecting them, to have as a reference when reconnecting.</p>	 <p>xx1800002846</p>
6	<p>Separate the SMB unit from the battery unit by cutting the cable strap.</p>	

Refitting the SMB unit and battery unit

Use these procedures to refit the SMB unit and battery unit.

Refitting the SMB unit and battery unit





	Action	Note
1	<p> ELECTROSTATIC DISCHARGE (ESD)</p> <p>The unit is sensitive to ESD. Before handling the unit read the safety information in section The unit is sensitive to ESD on page 45.</p>	

Continues on next page

5 Repair

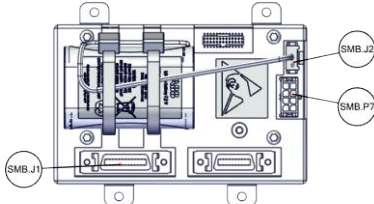

5.3.4 Replacing the SMB unit and battery unit

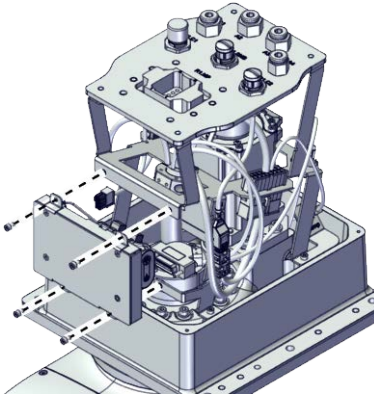
Continued

	Action	Note
2	<p>For robots with protection type Clean Room: Clean the joints that have been opened and wipe the parts free from particles with spirit on a lint free. See Cut the paint or surface on the robot before replacing parts on page 118</p> <p> Note</p> <p>After all repair work, wipe the Clean Room robot free from particles with spirit on a lint free cloth.</p>	
3	<p>Bind the SMB unit to the battery unit with the cable strap.</p>	
4	<p>Reconnect the connectors.</p> <ul style="list-style-type: none"> • SMB.P7 • SMB.J1 • SMB.J2 <p> Tip</p> <p>See the number markings on the connectors for help to find the corresponding connector.</p>	 <p>xx1800002846</p>
5	<p>Route and secure the cabling with cable straps if needed.</p> <p> CAUTION</p> <p>Correct cable routing is highly important. If the cables are routed and secured incorrectly the cables can be damaged.</p>	
6	<p>Refit the SMB package to the bracket with the screws.</p>	<p>Screws: Hex socket head cap screw M3x5 12.9 Lafre 2C2B/FC6.9 (2 pcs) Tightening torque: 1.5 Nm ±10%</p>  <p>xx1800002845</p>

Continues on next page

Refitting the base cover

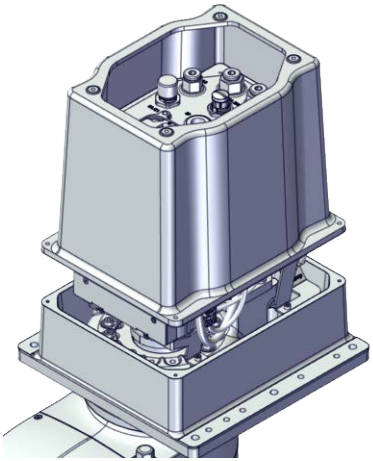
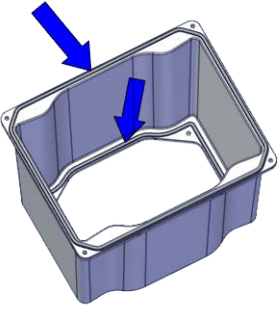
	Action	Note
1	<p>For robots with protection type Clean Room: Clean the joints that have been opened and wipe the parts free from particles with spirit on a lint free. See Cut the paint or surface on the robot before replacing parts on page 118</p> <p> Note</p> <p>After all repair work, wipe the Clean Room robot free from particles with spirit on a lint free cloth.</p>	
2	<p>Apply grease to the internal harness, cover all moving area of the harness.</p>	
3	<p>Apply grease to the covers that have contacting area with the harness.</p>	
4	<p>Refit the base cover.</p> <p> Note</p> <p>For robots with protection class IP54 (option 3350-540) For robots with protection type Clean Room (option 3351-1) Check the gasket for the base and the gasket for the base cover before refitting the base cover.</p> <p> Tip</p> <p>Replace the gasket if needed.</p>	 <p>xx1800002828</p> <p>For robots with protection class IP54 (option 3350-540) For robots with protection type Clean Room (option 3351-1)</p>  <p>xx1900001635</p>

Continues on next page

5 Repair

5.3.4 Replacing the SMB unit and battery unit

Continued

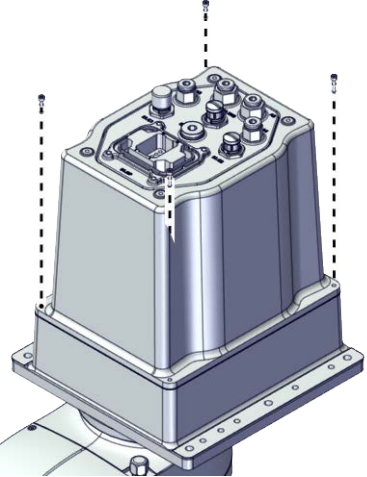
	Action	Note
5	Secure the base cover to the base with the screws.	<p>Screws: Hex socket head cap screw M3x12 12.9 Lafre 2C2B/FC6.9 (4 pcs) Tightening torque: 1.2 Nm \pm10%</p>  <p>xx1800002827</p>

Continues on next page

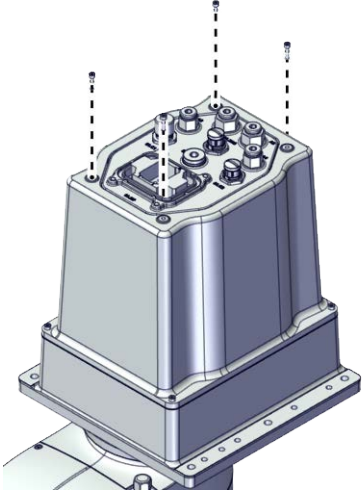
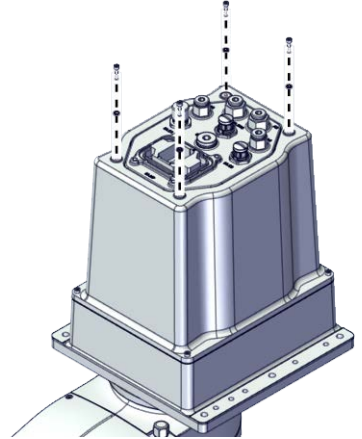
	Action	Note
6	<p>Secure the base harness to the base cover with the screws.</p> <p> Note</p> <p>For robots with protection class IP54 (option 3350-540)</p> <p>For robots with protection type Clean Room (option 3351-1)</p> <p>Refit the extra sealing washers on the base cover to the base harness.</p>	<p>For robots with protection class IP30 (option 3350-300)</p> <p>Screws: Hex socket head cap screw M3x12 12.9 Lafre 2C2B/FC6.9 (4 pcs)</p> <p>Tightening torque: 1.2 Nm ±10%</p>  <p>xx1800002826</p> <p>For robots with protection class IP54 (option 3350-540)</p> <p>For robots with protection type Clean Room (option 3351-1)</p> <p>Screws: Hex socket head cap screw M3x12 12.9 Lafre 2C2B/FC6.9 (4 pcs)</p> <p>Washers: Sealing washer M3 (4 pcs)</p> <p>Tightening torque: 1.2 Nm ±10%</p>  <p>xx1900001634</p>



Continues on next page

5 Repair

5.3.4 Replacing the SMB unit and battery unit

Continued

Concluding procedure

	Action	Note
1	<p>For robots with protection type Clean Room: Seal and paint the joints that have been opened. See Cut the paint or surface on the robot before replacing parts on page 118</p> <p> Note</p> <p>After all repair work, wipe the Clean Room robot free from particles with spirit on a lint free cloth.</p>	
2	Recalibrate the robot.	Calibration is detailed in section Calibration on page 771 .
3	<p> DANGER</p> <p>Make sure all safety requirements are met when performing the first test run. See Test run after installation, maintenance, or repair on page 56.</p>	

5.4 Base

5.4.1 Replacing the base

Location of the base

The base is located as shown in the figure.

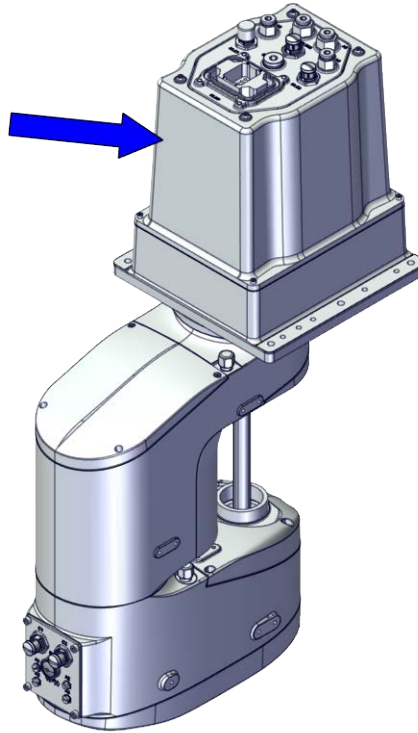

xx1800002823

Required spare parts



Note

The spare part numbers that are listed in the table can be out of date. See the latest spare parts of the IRB 910INV via myABB Business Portal, www.abb.com/myABB.

Spare part	Article number	Note
Base	3HAC073042-001	
Base cover, casting	3HAC073045-001	
Base, Clean Room	3HAC073224-001	Used with protection type Clean Room.
Base cover, casting, Clean Room	3HAC073225-001	Used with protection type Clean Room.
Gasket, cover	3HAC066628-001	
Gasket, cover	3HAC066625-001	

Continues on next page

5 Repair

5.4.1 Replacing the base

Continued

Spare part	Article number	Note
One-way valve	3HAC044906-001	
Sealing washer M3	3HAC065318-001	

Required tools and equipment

Equipment	Article number	Note
Standard toolkit	-	Content is defined in section Standard toolkit on page 840 .
Calibration tool box, Axis Calibration	3HAC074119-001	Delivered as a set of calibration tools. Required if Axis Calibration is the valid calibration method for the robot. ⁱ
Belt tension adjustment tool set, axis 1&2	-	Included in the special toolkit 3HAC073070-001. Used to adjust the tension of axis-1&2 timing belts. Special tool for L2
Sonic tension meter	-	Used for measuring the timing belt tension.
Handheld dynamometer	-	Used for measuring the timing belt tension.

ⁱ The robot is calibrated by either manual calibration or Axis Calibration at ABB factory before delivery. Always use the same calibration method as used at the factory. Information about valid calibration method is found on the calibration label or in the calibration menu on the FlexPendant.
If no data is found related to standard calibration, manual calibration is used as default.

Required consumables

Consumable	Article number	Note
Cable straps	-	
Grease	3HAC029132-001	FM 222 Used to lubricate the cable harness.

Deciding calibration routine

Decide which calibration routine to be used, based on the information in the table. Depending on which routine is chosen, action might be required prior to beginning the repair work of the robot, see the table.

	Action	Note
1	Decide which calibration routine to use for calibrating the robot. <ul style="list-style-type: none">Reference calibration. External cable packages (DressPack) and tools can stay fitted on the robot.Fine calibration. All external cable packages (DressPack) and tools must be removed from the robot.	

Continues on next page

Action	Note
<p>If the robot is to be calibrated with reference calibration: Find previous reference values for the axis or create new reference values. These values are to be used after the repair procedure is completed, for calibration of the robot. If no previous reference values exist, and no new reference values can be created, then reference calibration is not possible.</p>	<p>Follow the instructions given in the reference calibration routine on the FlexPendant to create reference values. Creating new values requires possibility to move the robot. Read more about reference calibration for Axis Calibration in Reference calibration routine on page 798.</p>
<p>If the robot is to be calibrated with fine calibration: Remove all external cable packages (DressPack) and tools from the robot.</p>	

Removing the base

Use these procedures to remove the base.

Preparations before removing the base

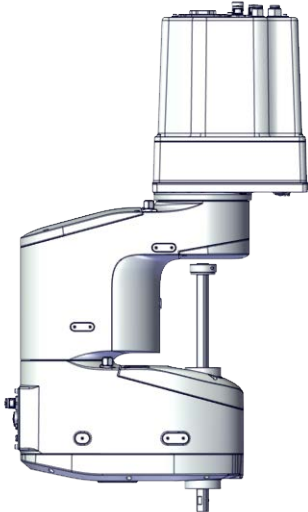

	Action	Note
1	Decide which calibration routine to use, and take actions accordingly prior to beginning the repair procedure.	
2	<p>If there is no enough space for the maintenance work, remove the robot from the wall and place it on the maintenance bracket.</p> <p> CAUTION</p> <p>Do not lay down the robot during the transportation, always keep it straight. If the robot lay down in any situation, the grease may come out from gearbox.</p>	
3	Jog all axes to zero position.	 <p>xx1800002825</p>

Continues on next page



5 Repair

5.4.1 Replacing the base

Continued

	Action	Note
4	 DANGER Turn off all: <ul style="list-style-type: none">• electric power supply• hydraulic pressure supply• air pressure supply to the robot, before entering the safeguarded space.	
5	 CAUTION For robots with protection type Clean Room Always cut the paint with a knife and grind the paint edge when disassembling parts of the robot! See Cut the paint or surface on the robot before replacing parts on page 118 .	

Removing the base cover

	Action	Note
1	 DANGER Make sure that all supplies for electrical power, hydraulic pressure, and air pressure are turned off.	
2	 CAUTION For robots with protection type Clean Room Always cut the paint with a knife and grind the paint edge when disassembling parts of the robot! See Cut the paint or surface on the robot before replacing parts on page 118 .	

Continues on next page

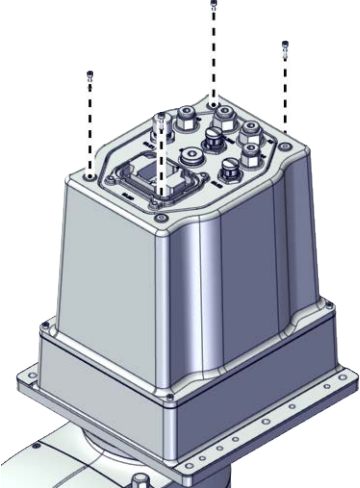
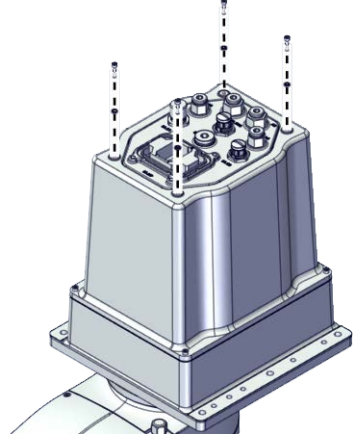
	Action	Note
3	<p>Remove the screws on the base cover to the base harness.</p> <p> Note</p> <p>For robots with protection class IP54 (option 3350-540)</p> <p>For robots with protection type Clean Room (option 3351-1)</p> <p>Remove the extra sealing washers on the base cover to the base harness.</p>	<p>For robots with protection class IP30 (option 3350-300)</p>  <p>xx1800002826</p> <p>For robots with protection class IP54 (option 3350-540)</p> <p>For robots with protection type Clean Room (option 3351-1)</p>  <p>xx1900001634</p>

Continues on next page



5 Repair

5.4.1 Replacing the base

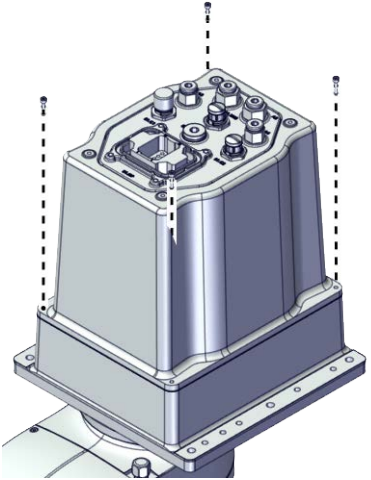
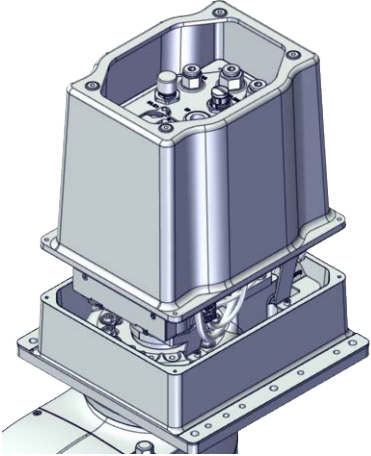

Continued

	Action	Note
4	Remove the screws on the base cover to the base.	 <p>xx1800002827</p>
5	Take the base cover out.	 <p>xx1800002828</p>

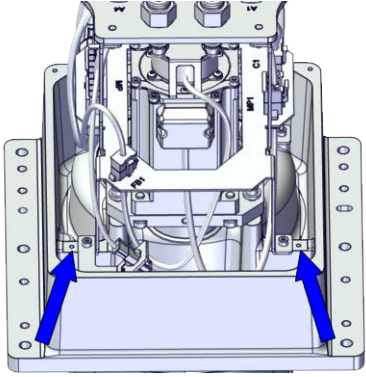

Disconnecting the connectors on the base harness

	Action	Note
1	 <p>DANGER</p> <p>Make sure that all supplies for electrical power, hydraulic pressure, and air pressure are turned off.</p>	
2	 <p>CAUTION</p> <p>For robots with protection type Clean Room Always cut the paint with a knife and grind the paint edge when disassembling parts of the robot! See Cut the paint or surface on the robot before replacing parts on page 118.</p>	

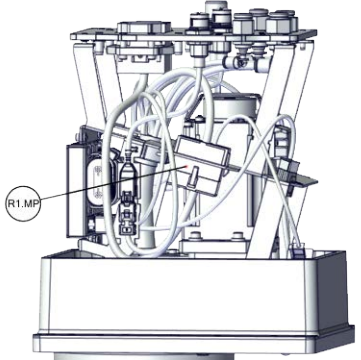
Continues on next page

	Action	Note
3	Remove the three grounding cables from the bracket by unscrew the screws.	 <p>xx1900000062</p>
4	Disconnect the connector. <ul style="list-style-type: none"> R1.MP  Tip Take photos of the connector and cable position before disconnecting them, to have as a reference when reconnecting.	 <p>xx1800002829</p>

Disconnecting the air hoses, C1 cabling and C2 cabling (if equipped)





	Action	Note
1	 DANGER Make sure that all supplies for electrical power, hydraulic pressure, and air pressure are turned off.	
2	 CAUTION For robots with protection type Clean Room Always cut the paint with a knife and grind the paint edge when disassembling parts of the robot! See Cut the paint or surface on the robot before replacing parts on page 118.	

Continues on next page

5 Repair

5.4.1 Replacing the base

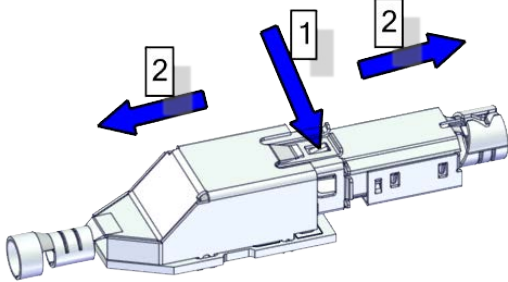
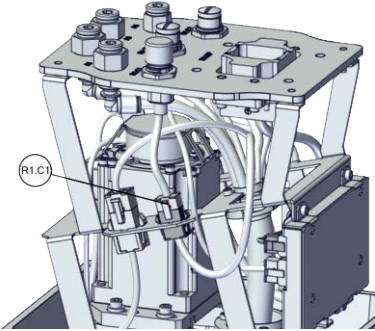
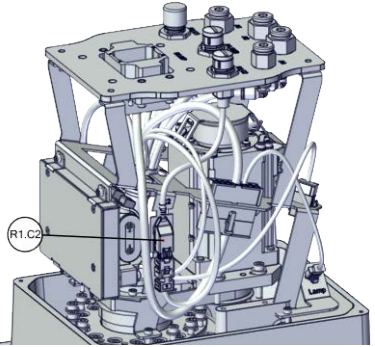

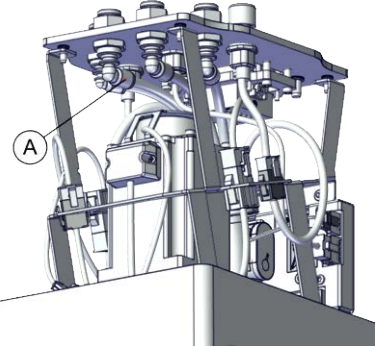
Continued

	Action	Note		
3	<p>Cut the cable straps and disconnect the connectors.</p> <ul style="list-style-type: none"> • R1.C1 • R1.C2 <p> Tip</p> <p>Take photos of the connector and cable position before disconnecting them, to have as a reference when reconnecting.</p> <p> Tip</p> <p>The connector clip has to be pressed (1) and pushed forward (2) to separate the R1.C2 (for C2 cabling).</p>  <p>xx1800002943</p>	 <p>xx1800002831</p>  <p>xx1800002832</p>		
4	<p>Disconnect the air hoses from the L-shaped connectors.</p> <p> Note</p> <p>Make sure that the air hoses are not bent or broken when you disconnect them.</p>	 <p>xx1800002830</p> <table border="1" data-bbox="1034 1615 1410 1659"> <tr> <td data-bbox="1034 1615 1086 1659">A</td> <td data-bbox="1086 1615 1410 1659">Air hoses</td> </tr> </table>	A	Air hoses
A	Air hoses			



Disconnecting the SMB cabling

	Action	Note
1	<p> DANGER</p> <p>Make sure that all supplies for electrical power, hydraulic pressure, and air pressure are turned off.</p>	

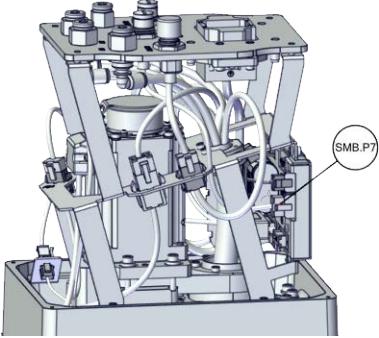
Continues on next page

	Action	Note
2	 ELECTROSTATIC DISCHARGE (ESD) The unit is sensitive to ESD. Before handling the unit read the safety information in section The unit is sensitive to ESD on page 45 .	
3	 CAUTION For robots with protection type Clean Room Always cut the paint with a knife and grind the paint edge when disassembling parts of the robot! See Cut the paint or surface on the robot before replacing parts on page 118 .	
4	Disconnect the connectors. <ul style="list-style-type: none"> • SMB.P7 • SMB.J1 (Only when the internal harness)  Tip Take photos of the connector and cable position before disconnecting them, to have as a reference when reconnecting.	 <p style="text-align: right;">SMB.P7</p> <p>xx1800002833</p>

Removing the base harness

	Action	Note
1	 DANGER Make sure that all supplies for electrical power, hydraulic pressure, and air pressure are turned off.	
2	 CAUTION For robots with protection type Clean Room Always cut the paint with a knife and grind the paint edge when disassembling parts of the robot! See Cut the paint or surface on the robot before replacing parts on page 118 .	

Continues on next page



5 Repair

5.4.1 Replacing the base

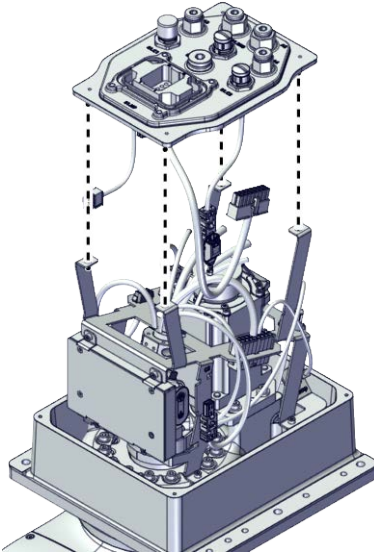
Continued

	Action	Note
3	Remove the base harness from the bracket.	 <p>xx1800002834</p>

Removing the bracket

	Action	Note
1	 <p>DANGER</p> <p>Make sure that all supplies for electrical power, hydraulic pressure, and air pressure are turned off.</p>	
2	 <p>CAUTION</p> <p>For robots with protection type Clean Room Always cut the paint with a knife and grind the paint edge when disassembling parts of the robot! See Cut the paint or surface on the robot before replacing parts on page 118.</p>	

Continues on next page

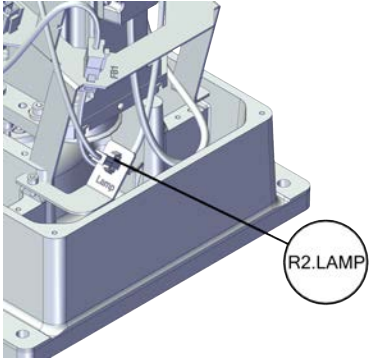
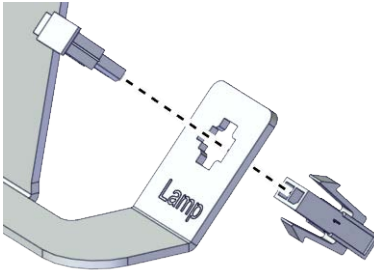
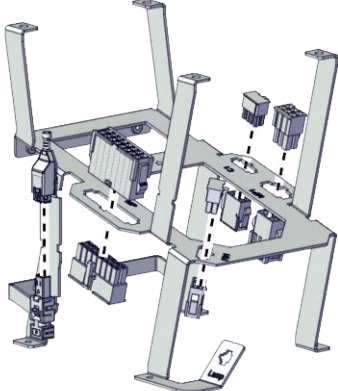
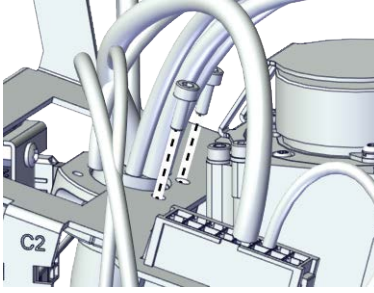
	Action	Note
3	Disconnect the lamp connector on the bracket.	 <p>xx1800002867</p>  <p>xx1900000079</p>
4	Snap loose and remove the female head of the connectors from the bracket.	 <p>xx1900000081</p>
5	Release the cable ferrule from the bracket.	 <p>xx1900000080</p>

Continues on next page



5 Repair

5.4.1 Replacing the base

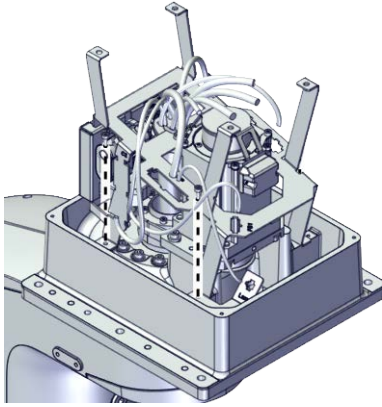
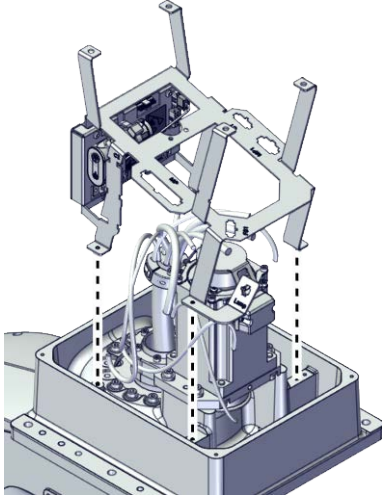
Continued

	Action	Note
6	Remove the screws on the bracket.	 <p>xx1800002868</p>
7	Remove the bracket.	 <p>xx1800002869</p>



Removing the axis-1 motor sub-assembly

	Action	Note
1	 DANGER Make sure that all supplies for electrical power, hydraulic pressure, and air pressure are turned off.	
2	 CAUTION For robots with protection type Clean Room Always cut the paint with a knife and grind the paint edge when disassembling parts of the robot! See Cut the paint or surface on the robot before replacing parts on page 118.	

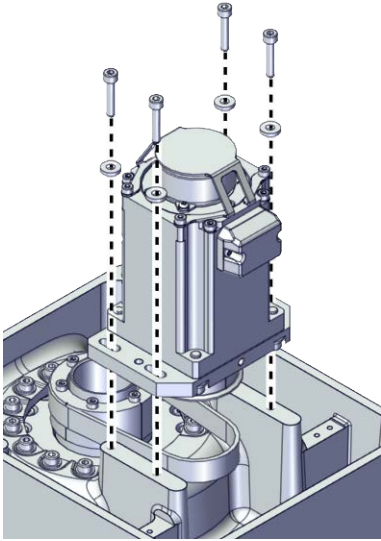
Continues on next page

	Action	Note
3	Remove the screws and washers.	 <p>xx1800002870</p>
4	Remove the motor and the timing belt.	

Removing the base

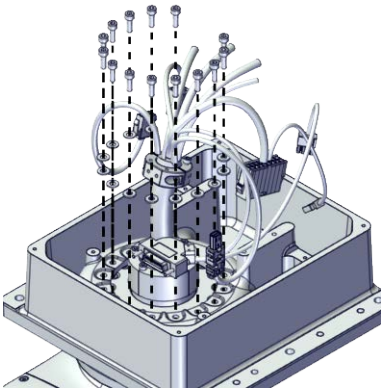
	Action	Note
1	 DANGER Make sure that all supplies for electrical power, hydraulic pressure, and air pressure are turned off.	
2	 CAUTION For robots with protection type Clean Room Always cut the paint with a knife and grind the paint edge when disassembling parts of the robot! See <i>Cut the paint or surface on the robot before replacing parts on page 118.</i>	
3	Remove the screws and washers.	 <p>xx1800002851</p>

Continues on next page



5 Repair

5.4.1 Replacing the base

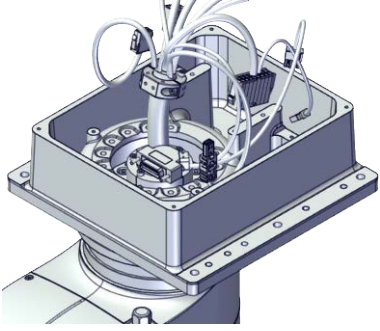
Continued

	Action	Note
4	Remove the base.	 <p>xx1800002852</p>

Removing the lamp and end cap from the base



	Action	Note
1	 DANGER Make sure that all supplies for electrical power, hydraulic pressure, and air pressure are turned off.	
2	 CAUTION For robots with protection type Clean Room Always cut the paint with a knife and grind the paint edge when disassembling parts of the robot! See Cut the paint or surface on the robot before replacing parts on page 118 .	
3	Remove the lamp by unscrewing it.	
4	Remove the end cap by unscrewing it.	
5	For robots with protection class IP54 (option 3350-540) For robots with protection type Clean Room (option 3351-1) Remove the one way valve by unscrewing it.	

Continues on next page

Refitting the base

Use these procedures to refit the base.

Refitting the lamp and end cap to the base

	Action	Note
1	<p>For robots with protection type Clean Room: Clean the joints that have been opened and wipe the parts free from particles with spirit on a lint free. See Cut the paint or surface on the robot before replacing parts on page 118</p> <p> Note After all repair work, wipe the Clean Room robot free from particles with spirit on a lint free cloth.</p>	
2	<p>Refit the lamp by screwing it into the base.</p> <p> Tip Just tighten it.</p>	
3	<p>Refit the end cap by by screwing it into the base.</p>	
4	<p>For robots with protection class IP54 (option 3350-540) For robots with protection type Clean Room (option 3351-1) Refit the one way valve by screwing it into the base.</p>	

Refitting the base

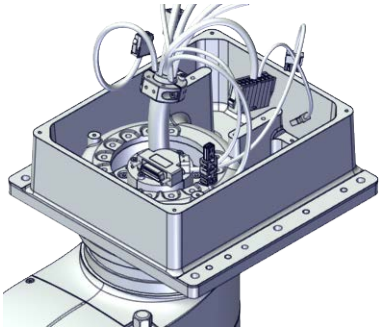
	Action	Note
1	<p>For robots with protection type Clean Room: Clean the joints that have been opened and wipe the parts free from particles with spirit on a lint free. See Cut the paint or surface on the robot before replacing parts on page 118</p> <p> Note After all repair work, wipe the Clean Room robot free from particles with spirit on a lint free cloth.</p>	
2	<p>Refit the base to the axis-1 gearbox as the illustration.</p>	 <p>xx1800002852</p>

Continues on next page

5 Repair

5.4.1 Replacing the base

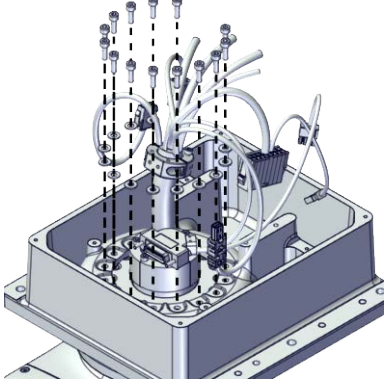

Continued

	Action	Note
3	Refit the screws.	<p>Screws: Hex socket head cap screw M4x12 12.9 Lafre 2C2B/FC6.9 (14 pcs) Tightening torque: 0.5 Nm-1 Nm-2 Nm-4 Nm $\pm 10\%$</p>  <p>xx1800002851</p>

Refitting the axis-1 motor sub-assembly

	Action	Note
1	<p>For robots with protection type Clean Room: Clean the joints that have been opened and wipe the parts free from particles with spirit on a lint free. See Cut the paint or surface on the robot before replacing parts on page 118</p> <p> Note</p> <p>After all repair work, wipe the Clean Room robot free from particles with spirit on a lint free cloth.</p>	

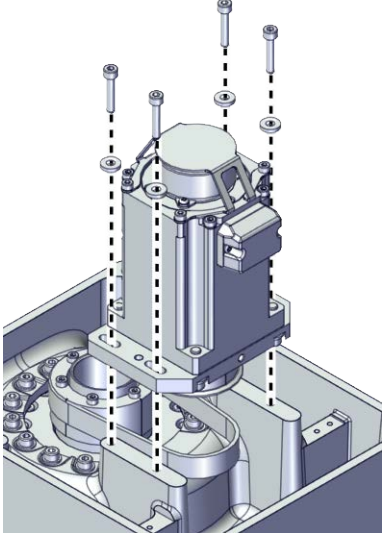
Continues on next page

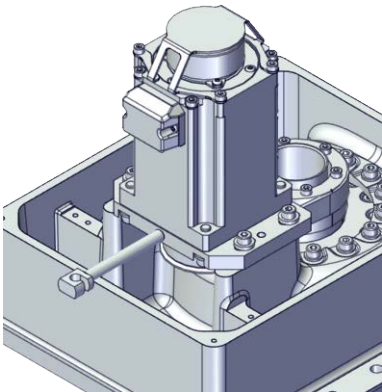
	Action	Note	
2	Refit the timing belt to the pulley.	Screws: Hex socket head cap screw M4x20 12.9 Lafre 2C2B/FC6.9 (4 pcs)	
3	Refit the motor.		
4	Refit the timing belt to the motor. Ensure that the belt runs correctly in the grooves.		Washers: Washer 4.3x10x2 steel (4 pcs)
5	Refit the screws and washers without fully tightened.	Tightening torque: 3 Nm \pm 10%  xx1800002870 Timing belt: 3HAC061864-001	
6	Install the axis1&2 belt tension adjustment tool to the motor.  Note Just tighten the tool.	Belt tension adjustment tool set, axis 1&2:-  xx1900000093	

5 Repair

5.4.1 Replacing the base

Continued

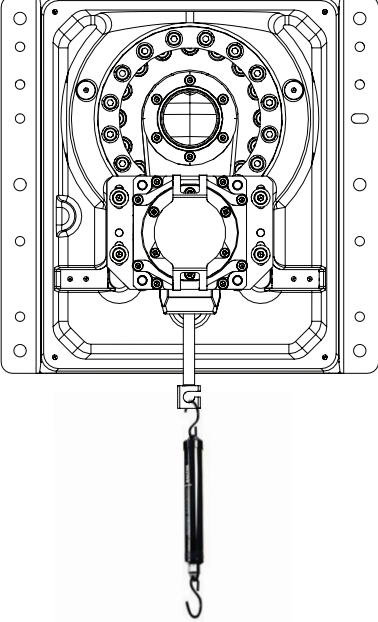
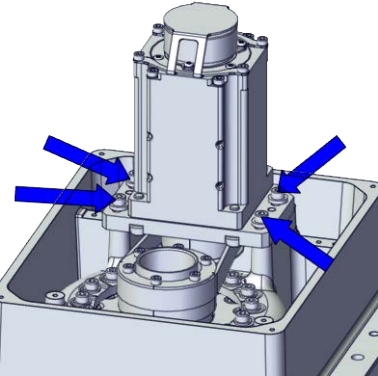

	Action	Note
7	<p>Use a handheld dynamometer hooking to the special tool and pull the dynamometer to make the tension falling in the allowed force range.</p> <p> Note</p> <p>During the measurement, make sure that all interferences that may affect the force are removed. Pay attention to the force application direction.</p>	<p>Used belt: 70-80N New belt:100-110N</p>  <p>xx1900000094</p>
8	<p>Fasten the screws to the recommended tightening torque.</p>	<p>Tightening torque: 3 Nm \pm10%</p>  <p>xx1800002871</p>
9	<p>Use a sonic tension meter to measure the timing belt tension.</p>	<p>Used belt: 250-305Hz New belt:296-378Hz</p>
10	<p>If the timing belt tension does not meet the requirement, loosen the motor screws and readjust.</p>	

Continues on next page

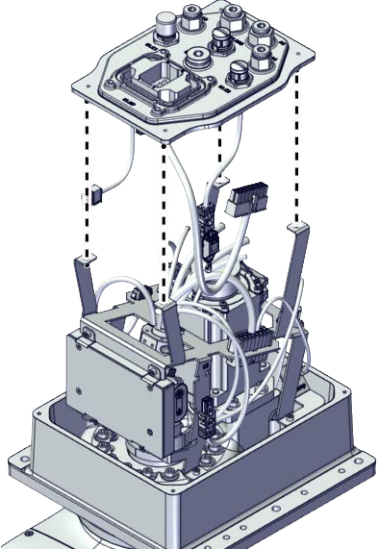
Refitting the base harness

	Action	Note
1	<p>For robots with protection type Clean Room: Clean the joints that have been opened and wipe the parts free from particles with spirit on a lint free. See Cut the paint or surface on the robot before replacing parts on page 118</p> <p> Note</p> <p>After all repair work, wipe the Clean Room robot free from particles with spirit on a lint free cloth.</p>	
2	<p>Refit the base harness to the bracket.</p>	 <p>xx1800002834</p>

Reconnecting the SMB cabling



	Action	Note
1	<p> ELECTROSTATIC DISCHARGE (ESD)</p> <p>The unit is sensitive to ESD. Before handling the unit read the safety information in section The unit is sensitive to ESD on page 45.</p>	
2	<p>For robots with protection type Clean Room: Clean the joints that have been opened and wipe the parts free from particles with spirit on a lint free. See Cut the paint or surface on the robot before replacing parts on page 118</p> <p> Note</p> <p>After all repair work, wipe the Clean Room robot free from particles with spirit on a lint free cloth.</p>	

Continues on next page

5 Repair

5.4.1 Replacing the base

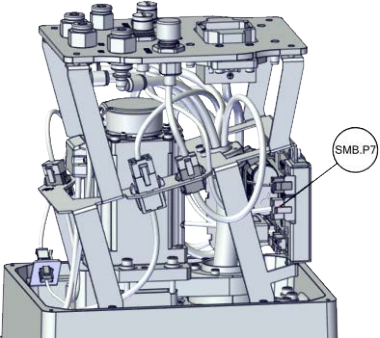

Continued

	Action	Note
3	<p>Reconnect the connectors.</p> <ul style="list-style-type: none">• SMB.P7• SMB.J1 <p> Tip</p> <p>See the number markings on the connectors for help to find the corresponding connector.</p>	 <p>xx1800002833</p>
4	<p>Route and secure the cabling with cable straps if needed.</p> <p> CAUTION</p> <p>Correct cable routing is highly important. If the cables are routed and secured incorrectly the cables can be damaged.</p>	

Refitting the bracket

	Action	Note
1	<p>For robots with protection type Clean Room: Clean the joints that have been opened and wipe the parts free from particles with spirit on a lint free. See Cut the paint or surface on the robot before replacing parts on page 118</p> <p> Note</p> <p>After all repair work, wipe the Clean Room robot free from particles with spirit on a lint free cloth.</p>	

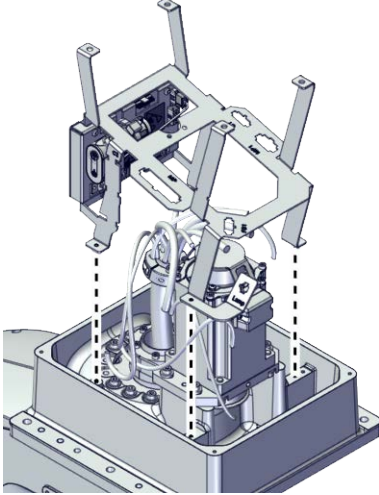
Continues on next page

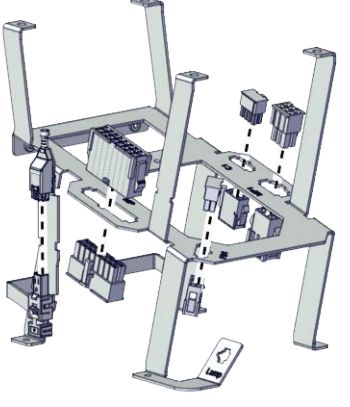
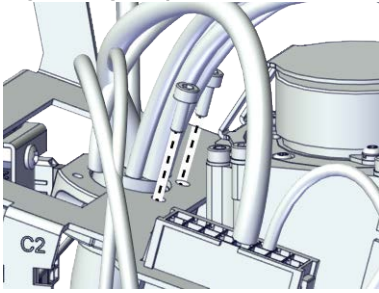
	Action	Note
2	Refit the bracket and secure with the screws.	<p>Screws: Hex socket head cap screw M3x8 12.9 Lafre 2C2B/FC6.9 (4 pcs) Tightening torque: 1.5 Nm \pm10%</p>  <p>xx1800002869</p>
3	<p>Insert the female head of the connectors to the bracket accordingly.</p> <p> Tip</p> <p>The mistake proofing measure has been applied to the connectors, the connectors may be damaged if excessive force is used.</p>	 <p>xx1900000081</p>
4	Secure the cable ferrule to the bracket with the screws.	<p>Screws: Hex socket head cap screw M3x5 12.9 Lafre 2C2B/FC6.9 (2 pcs) Tightening torque: 1.5 Nm \pm10%</p>  <p>xx1900000080</p>

Continues on next page



5 Repair

5.4.1 Replacing the base

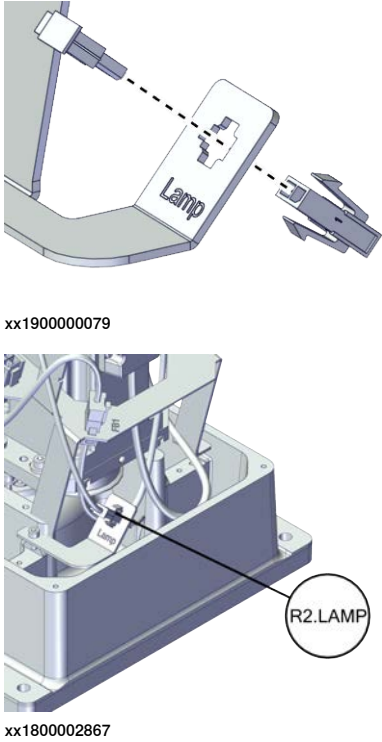

Continued

	Action	Note
5	Reconnect the lamp connector on the bracket.	 <p>xx190000079</p> <p>xx1800002867</p> <p>R2.LAMP</p>

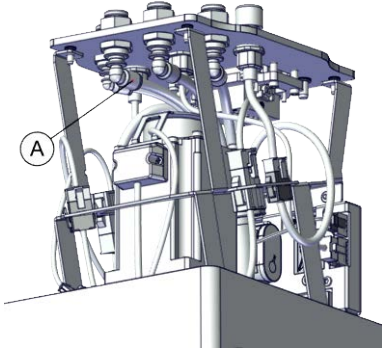
Reconnecting the air hoses, C1 cabling and C2 cabling (if equipped)

	Action	Note		
1	<p>For robots with protection type Clean Room: Clean the joints that have been opened and wipe the parts free from particles with spirit on a lint free. See Cut the paint or surface on the robot before replacing parts on page 118</p> <p> Note</p> <p>After all repair work, wipe the Clean Room robot free from particles with spirit on a lint free cloth.</p>			
2	<p>Reconnect the air hoses in a cross pattern to the L-shaped connectors on the base harness.</p> <p> Tip</p> <p>See the number markings on the air hoses for help to find the corresponding air hoses. The air hoses with the same number connect to the same L-shaped connector.</p> <p> Note</p> <p>Make sure that the air hoses are not bent or broken when you disconnect them.</p>	 <p>xx1800002830</p> <table border="1" data-bbox="1027 1921 1410 1973"> <tr> <td>A</td> <td>Air hoses</td> </tr> </table>	A	Air hoses
A	Air hoses			

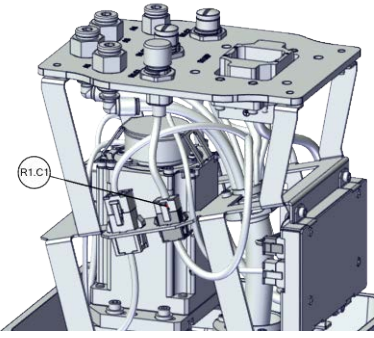
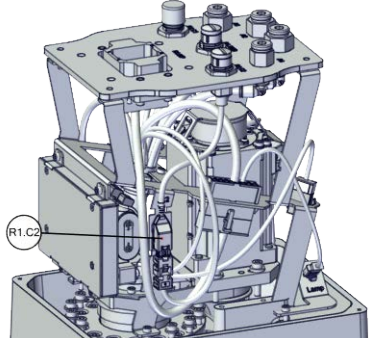
Continues on next page

	Action	Note
3	<p>Reconnect the connectors.</p> <ul style="list-style-type: none"> • R1.C1 • R1.C2 <p> Tip</p> <p>See the number markings on the connectors for help to find the corresponding connector.</p>	 <p>xx1800002831</p>  <p>xx1800002832</p>
4	<p>Route and secure the cabling with cable straps if needed.</p> <p> CAUTION</p> <p>Correct cable routing is highly important. If the cables are routed and secured incorrectly the cables can be damaged.</p>	



Reconnecting the connectors on the base harness

	Action	Note
1	<p>For robots with protection type Clean Room: Clean the joints that have been opened and wipe the parts free from particles with spirit on a lint free. See Cut the paint or surface on the robot before replacing parts on page 118</p> <p> Note</p> <p>After all repair work, wipe the Clean Room robot free from particles with spirit on a lint free cloth.</p>	

5 Repair

5.4.1 Replacing the base

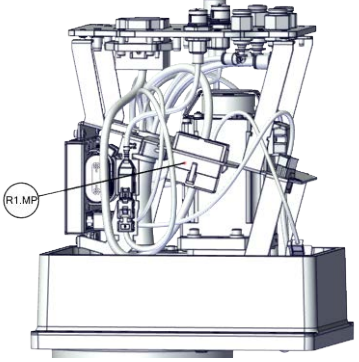
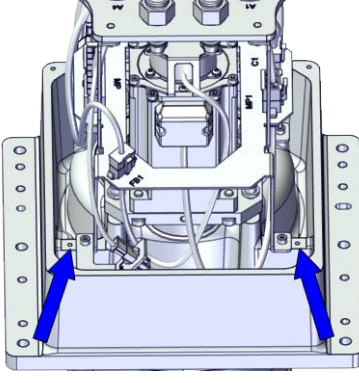

Continued

	Action	Note
2	<p>Reconnect the connector.</p> <ul style="list-style-type: none"> R1.MP <p> Tip</p> <p>See the number markings on the connectors for help to find the corresponding connector.</p>	 <p>xx1800002829</p>
3	<p>Secure the three grounding cables to the bracket with the screw.</p>	<p>Screws: Hex socket head cap screw M3x5 12.9 Lafre 2C2B/FC6.9 (2 pcs)</p> <p>Tightening torque: 1.5 Nm ±10%</p>  <p>xx1900000062</p>
4	<p>Route and secure the cabling with cable straps if needed.</p> <p> CAUTION</p> <p>Correct cable routing is highly important. If the cables are routed and secured incorrectly the cables can be damaged.</p>	

Refitting the base cover

	Action	Note
1	<p>For robots with protection type Clean Room:</p> <p>Clean the joints that have been opened and wipe the parts free from particles with spirit on a lint free. See Cut the paint or surface on the robot before replacing parts on page 118</p> <p> Note</p> <p>After all repair work, wipe the Clean Room robot free from particles with spirit on a lint free cloth.</p>	

Continues on next page

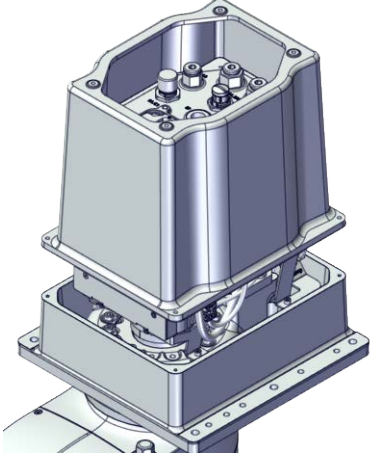
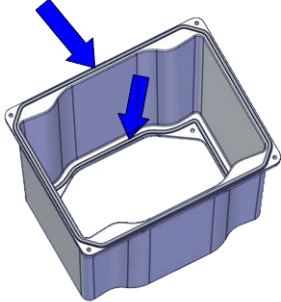
	Action	Note
2	Apply grease to the internal harness, cover all moving area of the harness.	
3	Apply grease to the covers that have contacting area with the harness.	
4	<p>Refit the base cover.</p> <p> Note</p> <p>For robots with protection class IP54 (option 3350-540)</p> <p>For robots with protection type Clean Room (option 3351-1)</p> <p>Check the gasket for the base and the gasket for the base cover before refitting the base cover.</p> <p> Tip</p> <p>Replace the gasket if needed.</p>	 <p>xx1800002828</p> <p>For robots with protection class IP54 (option 3350-540)</p> <p>For robots with protection type Clean Room (option 3351-1)</p>  <p>xx1900001635</p>

Continues on next page

5 Repair

5.4.1 Replacing the base

Continued

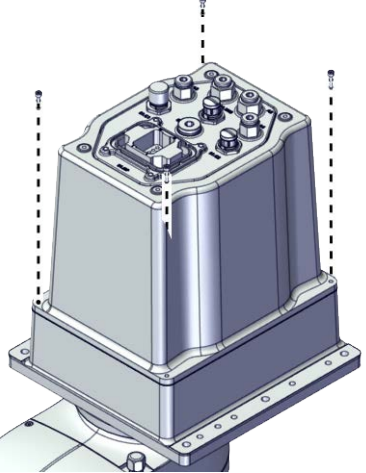
	Action	Note
5	Secure the base cover to the base with the screws.	<p>Screws: Hex socket head cap screw M3x12 12.9 Lafre 2C2B/FC6.9 (4 pcs) Tightening torque: 1.2 Nm \pm10%</p>  <p>xx1800002827</p>

Continues on next page

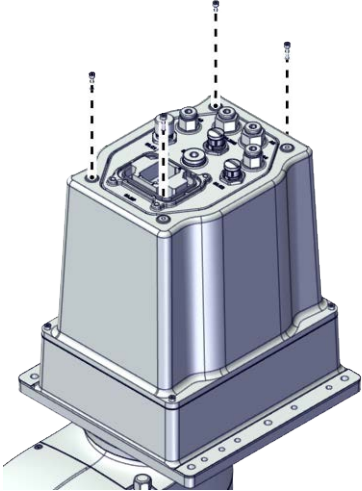
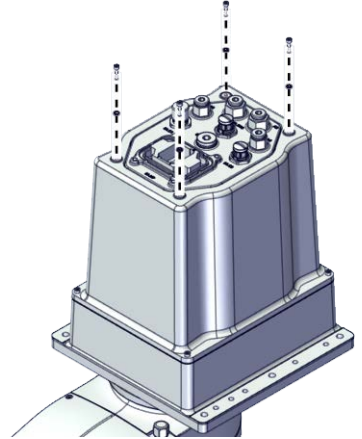
	Action	Note
6	<p>Secure the base harness to the base cover with the screws.</p> <p> Note</p> <p>For robots with protection class IP54 (option 3350-540)</p> <p>For robots with protection type Clean Room (option 3351-1)</p> <p>Refit the extra sealing washers on the base cover to the base harness.</p>	<p>For robots with protection class IP30 (option 3350-300)</p> <p>Screws: Hex socket head cap screw M3x12 12.9 Lafre 2C2B/FC6.9 (4 pcs)</p> <p>Tightening torque: 1.2 Nm ±10%</p>  <p>xx1800002826</p> <p>For robots with protection class IP54 (option 3350-540)</p> <p>For robots with protection type Clean Room (option 3351-1)</p> <p>Screws: Hex socket head cap screw M3x12 12.9 Lafre 2C2B/FC6.9 (4 pcs)</p> <p>Washers: Sealing washer M3 (4 pcs)</p> <p>Tightening torque: 1.2 Nm ±10%</p>  <p>xx1900001634</p>



Continues on next page

5 Repair

5.4.1 Replacing the base

Continued

Concluding procedure

	Action	Note
1	<p>For robots with protection type Clean Room: Seal and paint the joints that have been opened. See Cut the paint or surface on the robot before replacing parts on page 118</p> <p> Note</p> <p>After all repair work, wipe the Clean Room robot free from particles with spirit on a lint free cloth.</p>	
2	Recalibrate the robot.	Calibration is detailed in section Calibration on page 771 .
3	<p> DANGER</p> <p>Make sure all safety requirements are met when performing the first test run. See Test run after installation, maintenance, or repair on page 56.</p>	

5.4.2 Replacing the axis-1 timing belt

Location of the axis-1 timing belt

The axis-1 timing belt is located as shown in the figure.

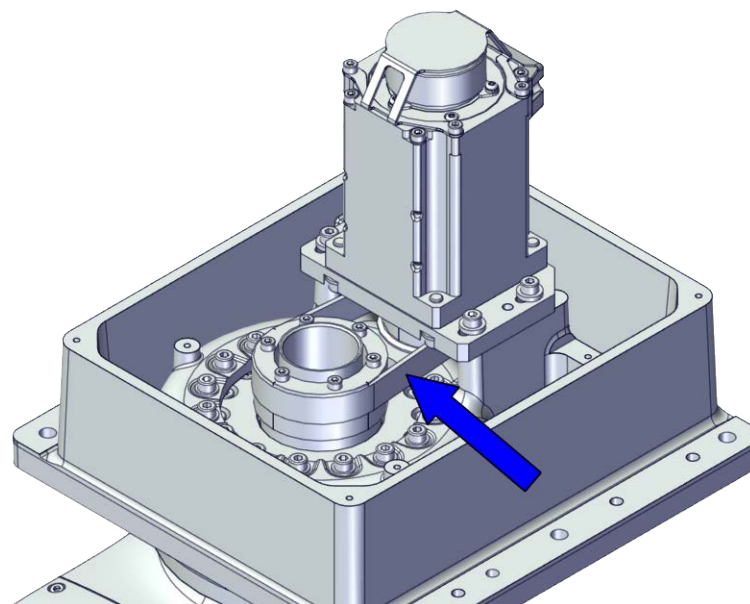

xx1800002853

Required spare parts



Note

The spare part numbers that are listed in the table can be out of date. See the latest spare parts of the IRB 910INV via myABB Business Portal, www.abb.com/myABB.

Spare part	Article number	Note
Timing belt	3HAC061864-001	

Required tools and equipment

Equipment	Article number	Note
Standard toolkit	-	Content is defined in section Standard toolkit on page 840 .
Calibration tool box, Axis Calibration	3HAC074119-001	Delivered as a set of calibration tools. Required if Axis Calibration is the valid calibration method for the robot. ⁱ
Sonic tension meter	-	Used for measuring the timing belt tension.

Continues on next page

5 Repair

5.4.2 Replacing the axis-1 timing belt

Continued

Equipment	Article number	Note
Handheld dynamometer	-	Used for measuring the timing belt tension.

- i The robot is calibrated by either manual calibration or Axis Calibration at ABB factory before delivery. Always use the same calibration method as used at the factory. Information about valid calibration method is found on the calibration label or in the calibration menu on the FlexPendant. If no data is found related to standard calibration, manual calibration is used as default.

Required consumables

Consumable	Article number	Note
Cable straps	-	
Grease	3HAC029132-001	FM 222 Used to lubricate the cable harness.

Deciding calibration routine

Decide which calibration routine to be used, based on the information in the table. Depending on which routine is chosen, action might be required prior to beginning the repair work of the robot, see the table.

	Action	Note
1	Decide which calibration routine to use for calibrating the robot. <ul style="list-style-type: none"> Reference calibration. External cable packages (DressPack) and tools can stay fitted on the robot. Fine calibration. All external cable packages (DressPack) and tools must be removed from the robot. 	
	<p>If the robot is to be calibrated with reference calibration:</p> <p>Find previous reference values for the axis or create new reference values. These values are to be used after the repair procedure is completed, for calibration of the robot.</p> <p>If no previous reference values exist, and no new reference values can be created, then reference calibration is not possible.</p>	<p>Follow the instructions given in the reference calibration routine on the FlexPendant to create reference values.</p> <p>Creating new values requires possibility to move the robot.</p> <p>Read more about reference calibration for Axis Calibration in Reference calibration routine on page 798.</p>
	<p>If the robot is to be calibrated with fine calibration:</p> <p>Remove all external cable packages (DressPack) and tools from the robot.</p>	



Continues on next page

Removing the axis-1 timing belt

Use these procedures to remove the axis-1 timing belt.

Preparations before removing the axis-1 timing belt

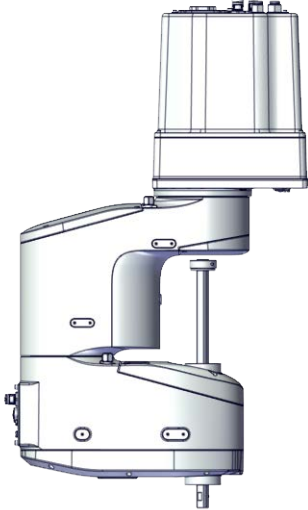
Remove the robot from the wall or enough space.

	Action	Note
1	Decide which calibration routine to use, and take actions accordingly prior to beginning the repair procedure.	
2	<p>If there is no enough space for the maintenance work, remove the robot from the wall and place it on the maintenance bracket.</p> <p> CAUTION</p> <p>Do not lay down the robot during the transportation, always keep it straight. If the robot lay down in any situation, the grease may come out from gearbox.</p>	
3	Jog all axes to zero position.	 <p>xx1800002825</p>
4	<p> DANGER</p> <p>Turn off all:</p> <ul style="list-style-type: none"> • electric power supply • hydraulic pressure supply • air pressure supply <p>to the robot, before entering the safeguarded space.</p>	

Continues on next page



5 Repair

5.4.2 Replacing the axis-1 timing belt

Continued

	Action	Note
5	 CAUTION For robots with protection type Clean Room Always cut the paint with a knife and grind the paint edge when disassembling parts of the robot! See <i>Cut the paint or surface on the robot before replacing parts on page 118.</i>	

Removing the base cover

	Action	Note
1	 DANGER Make sure that all supplies for electrical power, hydraulic pressure, and air pressure are turned off.	
2	 CAUTION For robots with protection type Clean Room Always cut the paint with a knife and grind the paint edge when disassembling parts of the robot! See <i>Cut the paint or surface on the robot before replacing parts on page 118.</i>	

Continues on next page

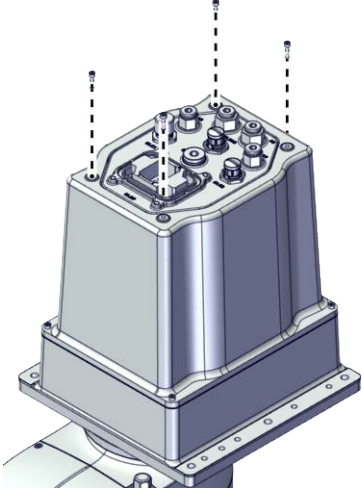
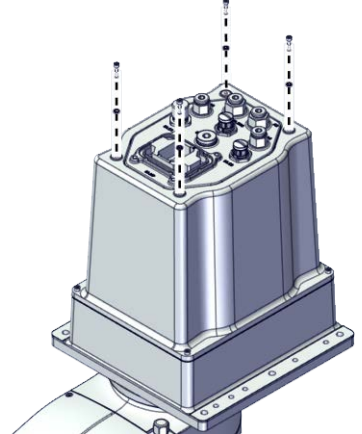
	Action	Note
3	<p>Remove the screws on the base cover to the base harness.</p> <p> Note</p> <p>For robots with protection class IP54 (option 3350-540)</p> <p>For robots with protection type Clean Room (option 3351-1)</p> <p>Remove the extra sealing washers on the base cover to the base harness.</p>	<p>For robots with protection class IP30 (option 3350-300)</p>  <p>xx1800002826</p> <p>For robots with protection class IP54 (option 3350-540)</p> <p>For robots with protection type Clean Room (option 3351-1)</p>  <p>xx1900001634</p>

Continues on next page



5 Repair

5.4.2 Replacing the axis-1 timing belt

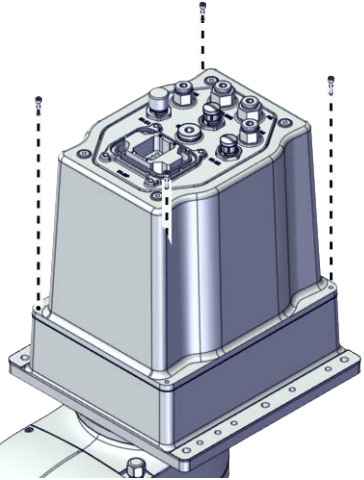
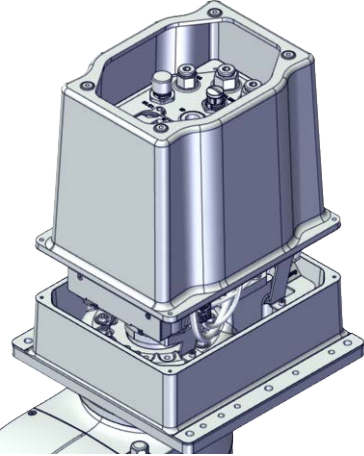

Continued

	Action	Note
4	Remove the screws on the base cover to the base.	 <p>xx1800002827</p>
5	Take the base cover out.	 <p>xx1800002828</p>

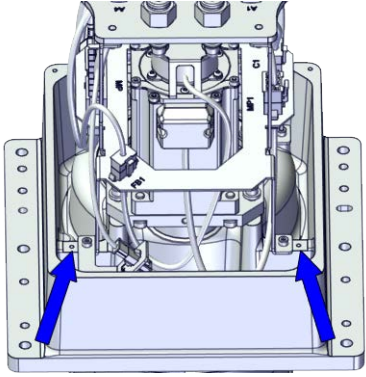

Disconnecting the connectors on the base harness

	Action	Note
1	 <p>DANGER</p> <p>Make sure that all supplies for electrical power, hydraulic pressure, and air pressure are turned off.</p>	
2	 <p>CAUTION</p> <p>For robots with protection type Clean Room Always cut the paint with a knife and grind the paint edge when disassembling parts of the robot! See Cut the paint or surface on the robot before replacing parts on page 118.</p>	

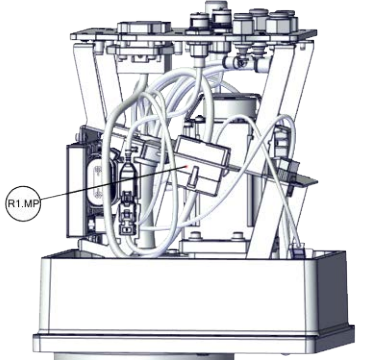
Continues on next page

	Action	Note
3	Remove the three grounding cables from the bracket by unscrew the screws.	 <p>xx1900000062</p>
4	Disconnect the connector. <ul style="list-style-type: none"> R1.MP  Tip Take photos of the connector and cable position before disconnecting them, to have as a reference when reconnecting.	 <p>xx1800002829</p>

Disconnecting the air hoses, C1 cabling and C2 cabling (if equipped)





	Action	Note
1	 DANGER Make sure that all supplies for electrical power, hydraulic pressure, and air pressure are turned off.	
2	 CAUTION For robots with protection type Clean Room Always cut the paint with a knife and grind the paint edge when disassembling parts of the robot! See Cut the paint or surface on the robot before replacing parts on page 118.	

Continues on next page

5 Repair

5.4.2 Replacing the axis-1 timing belt

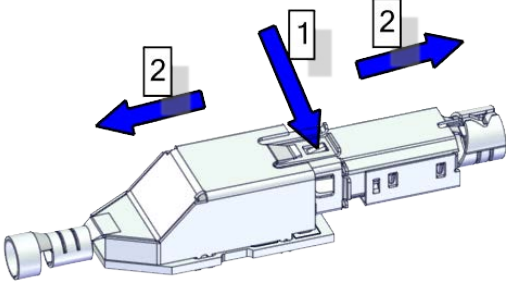
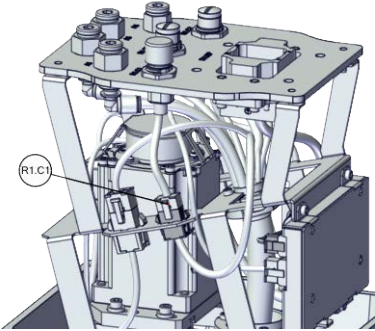
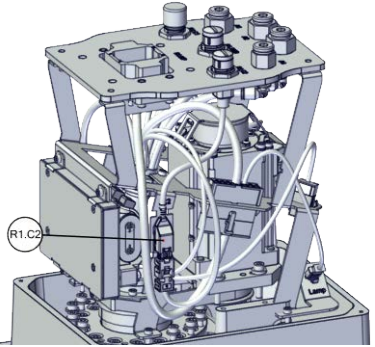

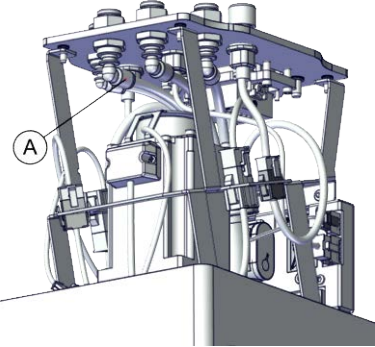
Continued

	Action	Note		
3	<p>Cut the cable straps and disconnect the connectors.</p> <ul style="list-style-type: none"> • R1.C1 • R1.C2 <p> Tip</p> <p>Take photos of the connector and cable position before disconnecting them, to have as a reference when reconnecting.</p> <p> Tip</p> <p>The connector clip has to be pressed (1) and pushed forward (2) to separate the R1.C2 (for C2 cabling).</p>  <p>xx1800002943</p>	 <p>xx1800002831</p>  <p>xx1800002832</p>		
4	<p>Disconnect the air hoses from the L-shaped connectors.</p> <p> Note</p> <p>Make sure that the air hoses are not bent or broken when you disconnect them.</p>	 <p>xx1800002830</p> <table border="1" data-bbox="1034 1615 1410 1659"> <tr> <td data-bbox="1034 1615 1086 1659">A</td> <td data-bbox="1086 1615 1410 1659">Air hoses</td> </tr> </table>	A	Air hoses
A	Air hoses			



Disconnecting the SMB cabling

	Action	Note
1	<p> DANGER</p> <p>Make sure that all supplies for electrical power, hydraulic pressure, and air pressure are turned off.</p>	

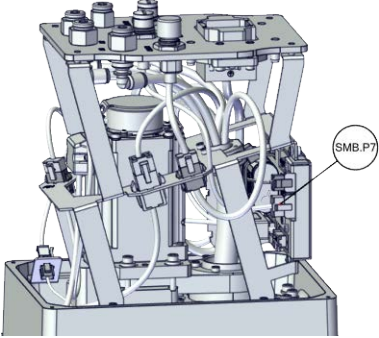
Continues on next page

	Action	Note
2	 ELECTROSTATIC DISCHARGE (ESD) The unit is sensitive to ESD. Before handling the unit read the safety information in section The unit is sensitive to ESD on page 45 .	
3	 CAUTION For robots with protection type Clean Room Always cut the paint with a knife and grind the paint edge when disassembling parts of the robot! See Cut the paint or surface on the robot before replacing parts on page 118 .	
4	Disconnect the connectors. <ul style="list-style-type: none"> • SMB.P7 • SMB.J1 (Only when the internal harness)  Tip Take photos of the connector and cable position before disconnecting them, to have as a reference when reconnecting.	 <p>xx1800002833</p>

Removing the base harness

	Action	Note
1	 DANGER Make sure that all supplies for electrical power, hydraulic pressure, and air pressure are turned off.	
2	 CAUTION For robots with protection type Clean Room Always cut the paint with a knife and grind the paint edge when disassembling parts of the robot! See Cut the paint or surface on the robot before replacing parts on page 118 .	



5 Repair

5.4.2 Replacing the axis-1 timing belt

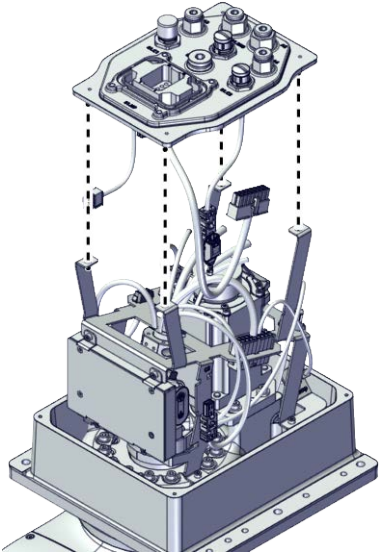
Continued

	Action	Note
3	Remove the base harness from the bracket.	 <p>xx1800002834</p>

Removing the bracket

	Action	Note
1	 <p>DANGER</p> <p>Make sure that all supplies for electrical power, hydraulic pressure, and air pressure are turned off.</p>	
2	 <p>CAUTION</p> <p>For robots with protection type Clean Room Always cut the paint with a knife and grind the paint edge when disassembling parts of the robot! See Cut the paint or surface on the robot before replacing parts on page 118.</p>	

Continues on next page

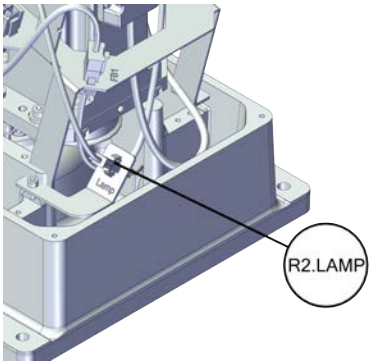
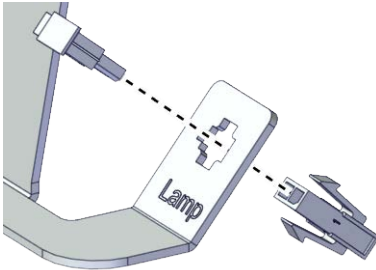
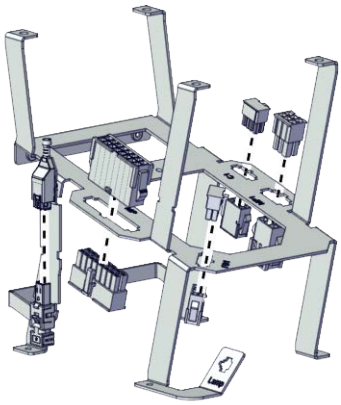
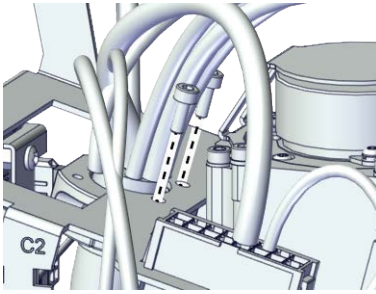
	Action	Note
3	Disconnect the lamp connector on the bracket.	 <p>xx1800002867</p>  <p>xx1900000079</p>
4	Snap loose and remove the female head of the connectors from the bracket.	 <p>xx1900000081</p>
5	Release the cable ferrule from the bracket.	 <p>xx1900000080</p>

Continues on next page



5 Repair

5.4.2 Replacing the axis-1 timing belt

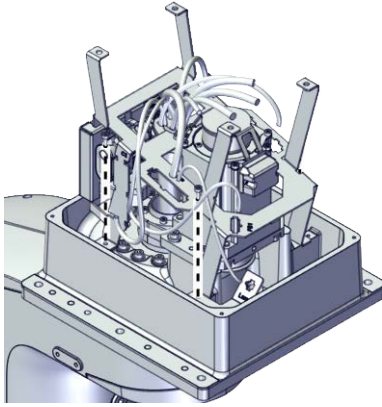
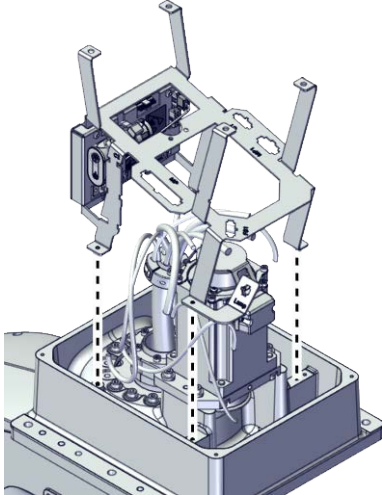
Continued

	Action	Note
6	Remove the screws on the bracket.	 <p>xx1800002868</p>
7	Remove the bracket.	 <p>xx1800002869</p>

Removing the axis-1 motor sub-assembly

	Action	Note
1	 DANGER Make sure that all supplies for electrical power, hydraulic pressure, and air pressure are turned off.	
2	 CAUTION For robots with protection type Clean Room Always cut the paint with a knife and grind the paint edge when disassembling parts of the robot! See Cut the paint or surface on the robot before replacing parts on page 118 .	

Continues on next page

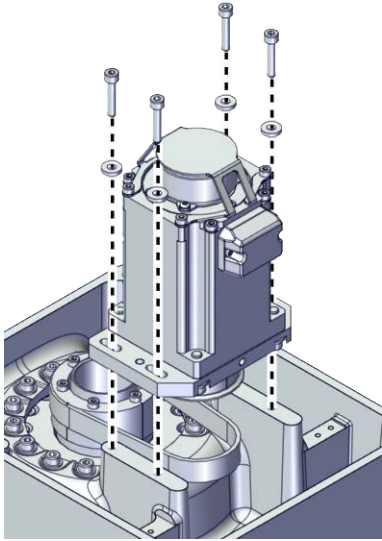
	Action	Note
3	Remove the screws and washers.	 <p data-bbox="1058 860 1166 880">xx1800002870</p>
4	Remove the motor and the timing belt.	

Refitting the axis-1 timing belt

Use these procedures to refit the axis-1 timing belt.

Refitting the axis-1 motor sub-assembly



	Action	Note
1	<p data-bbox="512 1144 1048 1285">For robots with protection type Clean Room: Clean the joints that have been opened and wipe the parts free from particles with spirit on a lint free. See Cut the paint or surface on the robot before replacing parts on page 118</p> <p data-bbox="512 1305 659 1350">  Note </p> <p data-bbox="512 1375 1048 1429">After all repair work, wipe the Clean Room robot free from particles with spirit on a lint free cloth.</p>	

Continues on next page

5 Repair

5.4.2 Replacing the axis-1 timing belt

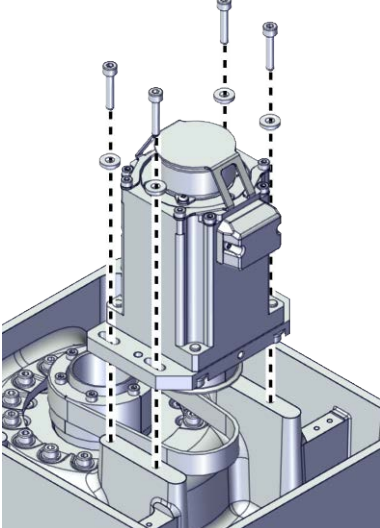
Continued

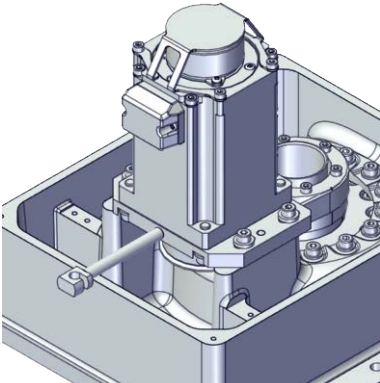
	Action	Note	
2	Refit the timing belt to the pulley.	Screws: Hex socket head cap screw M4x20 12.9 Lafre 2C2B/FC6.9 (4 pcs)	
3	Refit the motor.		
4	Refit the timing belt to the motor. Ensure that the belt runs correctly in the grooves.		Washers: Washer 4.3x10x2 steel (4 pcs)
5	Refit the screws and washers without fully tightened.	Tightening torque: 3 Nm \pm 10%  xx1800002870 Timing belt: 3HAC061864-001	
6	Install the axis1&2 belt tension adjustment tool to the motor.  Note Just tighten the tool.	Belt tension adjustment tool set, axis 1&2:-  xx1900000093	

Continues on next page

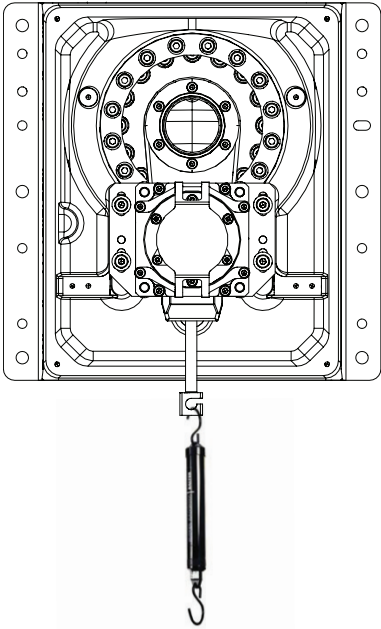
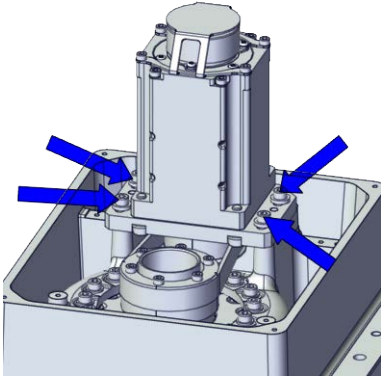
	Action	Note
7	<p>Use a handheld dynamometer hooking to the special tool and pull the dynamometer to make the tension falling in the allowed force range.</p> <p> Note</p> <p>During the measurement, make sure that all interferences that may affect the force are removed. Pay attention to the force application direction.</p>	<p>Used belt: 70-80N New belt:100-110N</p>  <p>xx1900000094</p>
8	<p>Fasten the screws to the recommended tightening torque.</p>	<p>Tightening torque: 3 Nm ±10%</p>  <p>xx1800002871</p>
9	<p>Use a sonic tension meter to measure the timing belt tension.</p>	<p>Used belt: 250-305Hz New belt:296-378Hz</p>
10	<p>If the timing belt tension does not meet the requirement, loosen the motor screws and readjust.</p>	

Continues on next page

5 Repair



5.4.2 Replacing the axis-1 timing belt

Continued

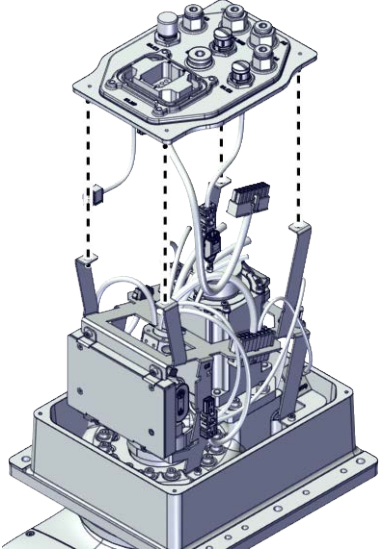

Refitting the base harness

	Action	Note
1	<p>For robots with protection type Clean Room: Clean the joints that have been opened and wipe the parts free from particles with spirit on a lint free. See Cut the paint or surface on the robot before replacing parts on page 118</p> <p> Note</p> <p>After all repair work, wipe the Clean Room robot free from particles with spirit on a lint free cloth.</p>	
2	<p>Refit the base harness to the bracket.</p>	 <p>xx1800002834</p>

Reconnecting the SMB cabling

	Action	Note
1	<p> ELECTROSTATIC DISCHARGE (ESD)</p> <p>The unit is sensitive to ESD. Before handling the unit read the safety information in section The unit is sensitive to ESD on page 45.</p>	
2	<p>For robots with protection type Clean Room: Clean the joints that have been opened and wipe the parts free from particles with spirit on a lint free. See Cut the paint or surface on the robot before replacing parts on page 118</p> <p> Note</p> <p>After all repair work, wipe the Clean Room robot free from particles with spirit on a lint free cloth.</p>	

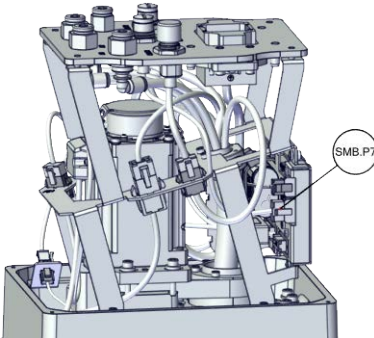
Continues on next page

	Action	Note
3	<p>Reconnect the connectors.</p> <ul style="list-style-type: none"> • SMB.P7 • SMB.J1 <p> Tip</p> <p>See the number markings on the connectors for help to find the corresponding connector.</p>	 <p>xx1800002833</p>
4	<p>Route and secure the cabling with cable straps if needed.</p> <p> CAUTION</p> <p>Correct cable routing is highly important. If the cables are routed and secured incorrectly the cables can be damaged.</p>	



Refitting the bracket

	Action	Note
1	<p>For robots with protection type Clean Room: Clean the joints that have been opened and wipe the parts free from particles with spirit on a lint free. See Cut the paint or surface on the robot before replacing parts on page 118</p> <p> Note</p> <p>After all repair work, wipe the Clean Room robot free from particles with spirit on a lint free cloth.</p>	

5 Repair

5.4.2 Replacing the axis-1 timing belt

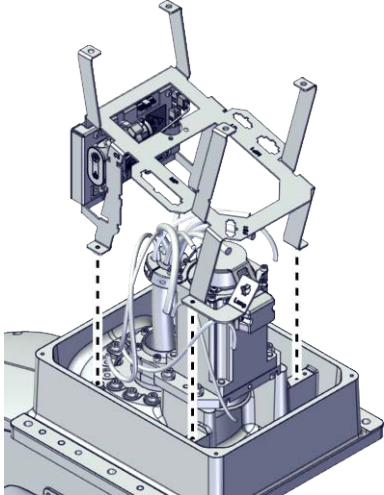
Continued

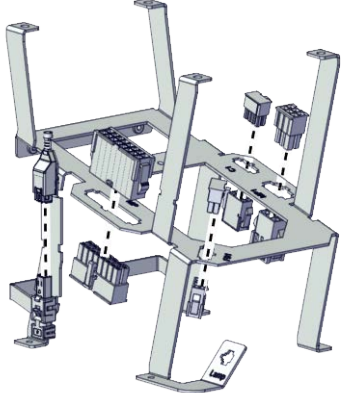
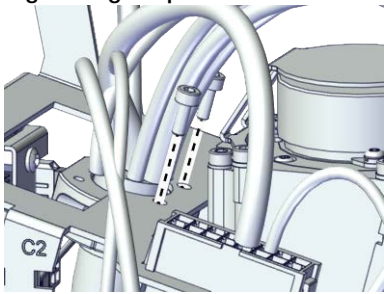

	Action	Note
2	Refit the bracket and secure with the screws.	<p>Screws: Hex socket head cap screw M3x8 12.9 Lafre 2C2B/FC6.9 (4 pcs) Tightening torque: 1.5 Nm \pm10%</p>  <p>xx1800002869</p>
3	<p>Insert the female head of the connectors to the bracket accordingly.</p> <p> Tip</p> <p>The mistake proofing measure has been applied to the connectors, the connectors may be damaged if excessive force is used.</p>	 <p>xx1900000081</p>
4	Secure the cable ferrule to the bracket with the screws.	<p>Screws: Hex socket head cap screw M3x5 12.9 Lafre 2C2B/FC6.9 (2 pcs) Tightening torque: 1.5 Nm \pm10%</p>  <p>xx1900000080</p>

Continues on next page

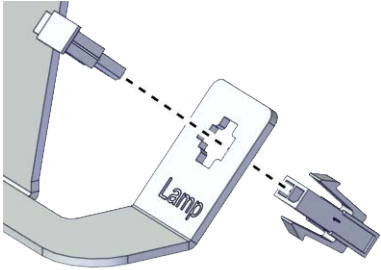
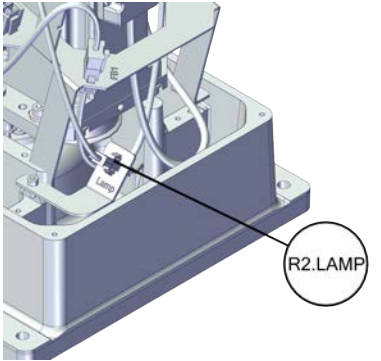
5.4.2 Replacing the axis-1 timing belt
Continued

	Action	Note
5	Reconnect the lamp connector on the bracket.	 <p>xx190000079</p>  <p>xx1800002867</p>

Reconnecting the air hoses, C1 cabling and C2 cabling (if equipped)

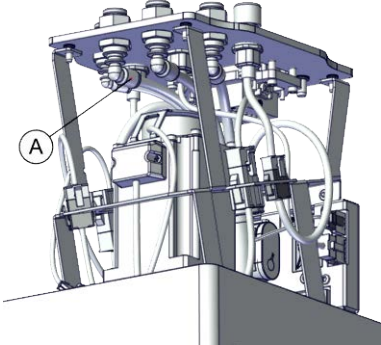

	Action	Note		
1	<p>For robots with protection type Clean Room: Clean the joints that have been opened and wipe the parts free from particles with spirit on a lint free. See Cut the paint or surface on the robot before replacing parts on page 118</p> <p> Note</p> <p>After all repair work, wipe the Clean Room robot free from particles with spirit on a lint free cloth.</p>			
2	<p>Reconnect the air hoses in a cross pattern to the L-shaped connectors on the base harness.</p> <p> Tip</p> <p>See the number markings on the air hoses for help to find the corresponding air hoses. The air hoses with the same number connect to the same L-shaped connector.</p> <p> Note</p> <p>Make sure that the air hoses are not bent or broken when you disconnect them.</p>	 <p>xx1800002830</p> <table border="1" data-bbox="1059 1921 1441 1971"> <tr> <td data-bbox="1059 1921 1118 1971">A</td> <td data-bbox="1118 1921 1441 1971">Air hoses</td> </tr> </table>	A	Air hoses
A	Air hoses			

Continues on next page

5 Repair

5.4.2 Replacing the axis-1 timing belt

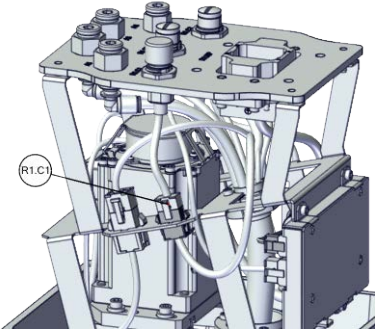
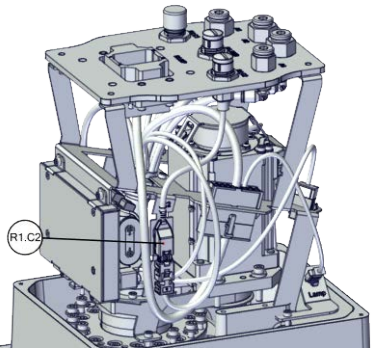

Continued

	Action	Note
3	<p>Reconnect the connectors.</p> <ul style="list-style-type: none"> • R1.C1 • R1.C2 <p> Tip</p> <p>See the number markings on the connectors for help to find the corresponding connector.</p>	 <p>xx1800002831</p>  <p>xx1800002832</p>
4	<p>Route and secure the cabling with cable straps if needed.</p> <p> CAUTION</p> <p>Correct cable routing is highly important. If the cables are routed and secured incorrectly the cables can be damaged.</p>	

Reconnecting the connectors on the base harness

	Action	Note
1	<p>For robots with protection type Clean Room: Clean the joints that have been opened and wipe the parts free from particles with spirit on a lint free. See Cut the paint or surface on the robot before replacing parts on page 118</p> <p> Note</p> <p>After all repair work, wipe the Clean Room robot free from particles with spirit on a lint free cloth.</p>	

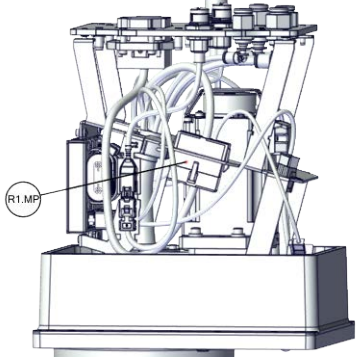
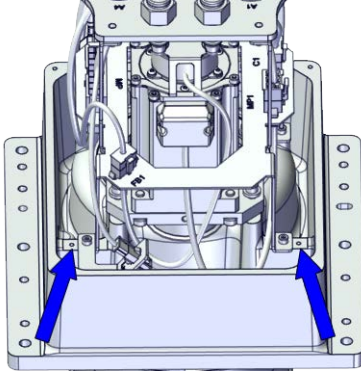
Continues on next page

	Action	Note
2	<p>Reconnect the connector.</p> <ul style="list-style-type: none"> R1.MP <p> Tip</p> <p>See the number markings on the connectors for help to find the corresponding connector.</p>	 <p>xx1800002829</p>
3	<p>Secure the three grounding cables to the bracket with the screw.</p>	<p>Screws: Hex socket head cap screw M3x5 12.9 Lafre 2C2B/FC6.9 (2 pcs)</p> <p>Tightening torque: 1.5 Nm ±10%</p>  <p>xx1900000062</p>
4	<p>Route and secure the cabling with cable straps if needed.</p> <p> CAUTION</p> <p>Correct cable routing is highly important. If the cables are routed and secured incorrectly the cables can be damaged.</p>	

Refitting the base cover



	Action	Note
1	<p>For robots with protection type Clean Room:</p> <p>Clean the joints that have been opened and wipe the parts free from particles with spirit on a lint free. See Cut the paint or surface on the robot before replacing parts on page 118</p> <p> Note</p> <p>After all repair work, wipe the Clean Room robot free from particles with spirit on a lint free cloth.</p>	

Continues on next page

5 Repair

5.4.2 Replacing the axis-1 timing belt

Continued

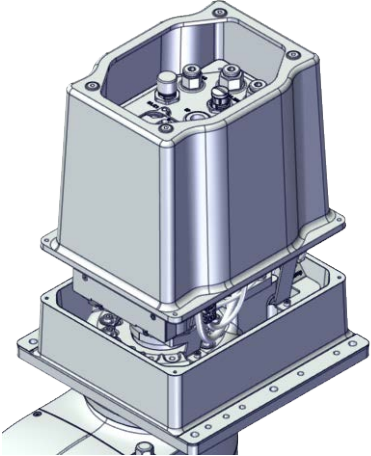
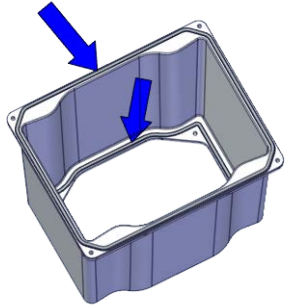
	Action	Note
2	Apply grease to the internal harness, cover all moving area of the harness.	
3	Apply grease to the covers that have contacting area with the harness.	
4	<p>Refit the base cover.</p> <p> Note</p> <p>For robots with protection class IP54 (option 3350-540)</p> <p>For robots with protection type Clean Room (option 3351-1)</p> <p>Check the gasket for the base and the gasket for the base cover before refitting the base cover.</p> <p> Tip</p> <p>Replace the gasket if needed.</p>	 <p>xx1800002828</p> <p>For robots with protection class IP54 (option 3350-540)</p> <p>For robots with protection type Clean Room (option 3351-1)</p>  <p>xx1900001635</p>

Continues on next page

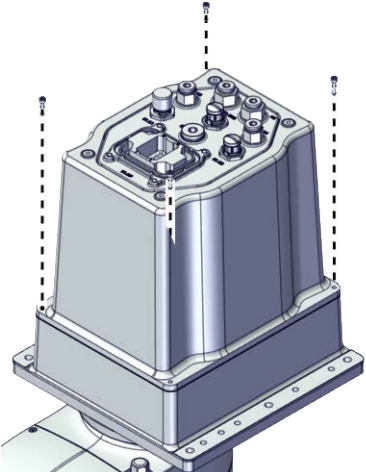
	Action	Note
5	Secure the base cover to the base with the screws.	<p>Screws: Hex socket head cap screw M3x12 12.9 Lafre 2C2B/FC6.9 (4 pcs) Tightening torque: 1.2 Nm \pm10%</p>  <p>xx1800002827</p>

5 Repair

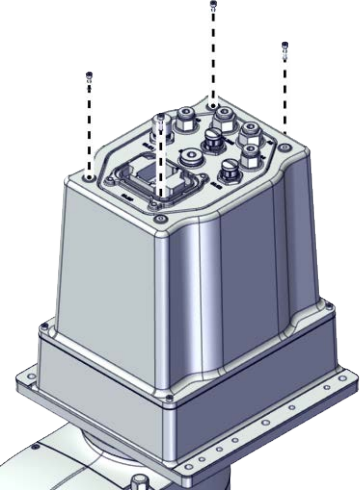
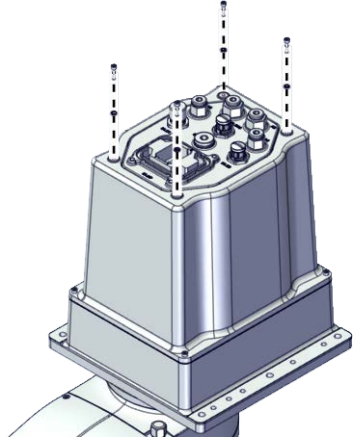

5.4.2 Replacing the axis-1 timing belt

Continued

	Action	Note
6	<p>Secure the base harness to the base cover with the screws.</p> <p> Note</p> <p>For robots with protection class IP54 (option 3350-540)</p> <p>For robots with protection type Clean Room (option 3351-1)</p> <p>Refit the extra sealing washers on the base cover to the base harness.</p>	<p>For robots with protection class IP30 (option 3350-300)</p> <p>Screws: Hex socket head cap screw M3x12 12.9 Lafre 2C2B/FC6.9 (4 pcs)</p> <p>Tightening torque: 1.2 Nm \pm10%</p>  <p>xx1800002826</p> <p>For robots with protection class IP54 (option 3350-540)</p> <p>For robots with protection type Clean Room (option 3351-1)</p> <p>Screws: Hex socket head cap screw M3x12 12.9 Lafre 2C2B/FC6.9 (4 pcs)</p> <p>Washers: Sealing washer M3 (4 pcs)</p> <p>Tightening torque: 1.2 Nm \pm10%</p>  <p>xx1900001634</p>

Continues on next page

Concluding procedure

	Action	Note
1	<p>For robots with protection type Clean Room: Seal and paint the joints that have been opened. See Cut the paint or surface on the robot before replacing parts on page 118</p> <p> Note</p> <p>After all repair work, wipe the Clean Room robot free from particles with spirit on a lint free cloth.</p>	
2	Recalibrate the robot.	Calibration is detailed in section Calibration on page 771 .
3	<p> DANGER</p> <p>Make sure all safety requirements are met when performing the first test run. See Test run after installation, maintenance, or repair on page 56.</p>	

5 Repair

5.5.1 Replacing the inner arm

5.5 Inner arm

5.5.1 Replacing the inner arm

Location of the inner arm

The inner arm is located as shown in the figure.

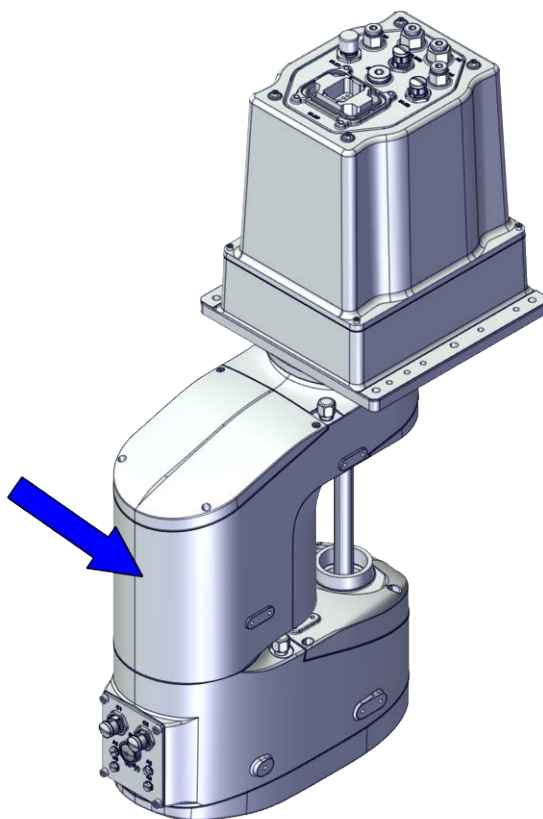

xx1800002854

Required spare parts



Note

The spare part numbers that are listed in the table can be out of date. See the latest spare parts of the IRB 910INV via myABB Business Portal, www.abb.com/myABB.

Spare part	Article number	Note
Inner arm, 350 mm	3HAC073048-001	
Inner arm, 550 mm	3HAC073063-001	
Inner arm cover	3HAC073049-001	
Inner arm cover casting	3HAC073050-001	
Inner arm, 350 mm, Clean Room	3HAC073226-001	Used with protection type Clean Room.

Continues on next page

Spare part	Article number	Note
Inner arm, 550 mm, Clean Room	3HAC073232-001	Used with protection type Clean Room.
Inner arm cover, Clean Room	3HAC073227-001	Used with protection type Clean Room.
Inner arm cover casting, Clean Room	3HAC073228-001	Used with protection type Clean Room.
Gasket, cover	3HAC066627-001	Replace if damaged.
Gasket, casting cover	3HAC066626-001	Replace if damaged.

Required tools and equipment

Equipment	Article number	Note
Standard toolkit	-	Content is defined in section Standard toolkit on page 840 .
Calibration tool box, Axis Calibration	3HAC074119-001	Delivered as a set of calibration tools. Required if Axis Calibration is the valid calibration method for the robot. ⁱ
Belt tension adjustment tool set, axis 1&2	-	Included in the special toolkit 3HAC073070-001. Used to adjust the tension of axis-1&2 timing belts. Special tool for L2
Sonic tension meter	-	Used for measuring the timing belt tension.
Handheld dynamometer	-	Used for measuring the timing belt tension.

ⁱ The robot is calibrated by either manual calibration or Axis Calibration at ABB factory before delivery. Always use the same calibration method as used at the factory.
Information about valid calibration method is found on the calibration label or in the calibration menu on the FlexPendant.
If no data is found related to standard calibration, manual calibration is used as default.

Required consumables

Consumable	Article number	Note
Cable straps	-	
Grease	3HAC029132-001	FM 222 Used to lubricate the cable harness.

Continues on next page

5 Repair

5.5.1 Replacing the inner arm

Continued

Deciding calibration routine

Decide which calibration routine to be used, based on the information in the table. Depending on which routine is chosen, action might be required prior to beginning the repair work of the robot, see the table.

	Action	Note
1	Decide which calibration routine to use for calibrating the robot. <ul style="list-style-type: none">Reference calibration. External cable packages (DressPack) and tools can stay fitted on the robot.Fine calibration. All external cable packages (DressPack) and tools must be removed from the robot.	
	If the robot is to be calibrated with reference calibration: Find previous reference values for the axis or create new reference values. These values are to be used after the repair procedure is completed, for calibration of the robot. If no previous reference values exist, and no new reference values can be created, then reference calibration is not possible.	Follow the instructions given in the reference calibration routine on the FlexPendant to create reference values. Creating new values requires possibility to move the robot. Read more about reference calibration for Axis Calibration in Reference calibration routine on page 798 .
	If the robot is to be calibrated with fine calibration: Remove all external cable packages (DressPack) and tools from the robot.	



Removing the inner arm

Use these procedures to remove the inner arm.

Preparations before removing the inner arm

	Action	Note
1	Decide which calibration routine to use, and take actions accordingly prior to beginning the repair procedure.	
2	If there is no enough space for the maintenance work, remove the robot from the wall and place it on the maintenance bracket.  CAUTION Do not lay down the robot during the transportation, always keep it straight. If the robot lay down in any situation, the grease may come out from gearbox.	

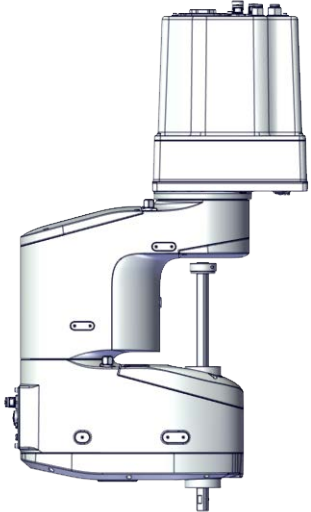
Continues on next page

	Action	Note
3	Jog all axes to zero position.	 <p>xx1800002825</p>
4	 <p>DANGER</p> <p>Turn off all:</p> <ul style="list-style-type: none"> • electric power supply • hydraulic pressure supply • air pressure supply <p>to the robot, before entering the safeguarded space.</p>	
5	 <p>CAUTION</p> <p>For robots with protection type Clean Room</p> <p>Always cut the paint with a knife and grind the paint edge when disassembling parts of the robot!</p> <p>See Cut the paint or surface on the robot before replacing parts on page 118.</p>	



Removing the base cover

	Action	Note
1	 <p>DANGER</p> <p>Make sure that all supplies for electrical power, hydraulic pressure, and air pressure are turned off.</p>	

5 Repair

5.5.1 Replacing the inner arm

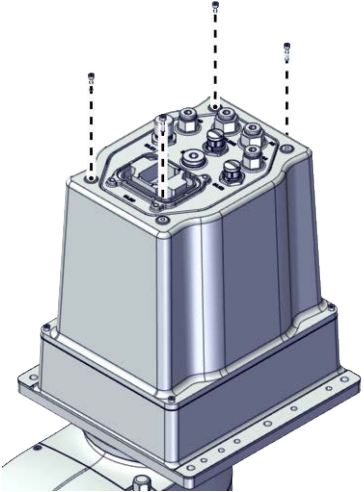
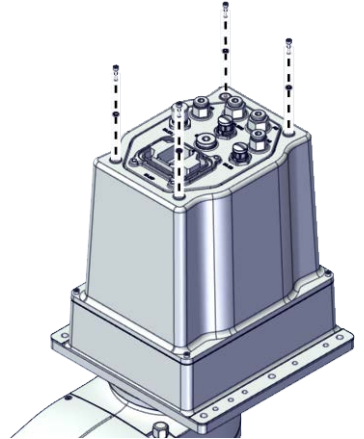

Continued

	Action	Note
2	<p> CAUTION</p> <p>For robots with protection type Clean Room Always cut the paint with a knife and grind the paint edge when disassembling parts of the robot! See <i>Cut the paint or surface on the robot before replacing parts on page 118.</i></p>	
3	<p>Remove the screws on the base cover to the base harness.</p> <p> Note</p> <p>For robots with protection class IP54 (option 3350-540) For robots with protection type Clean Room (option 3351-1) Remove the extra sealing washers on the base cover to the base harness.</p>	<p>For robots with protection class IP30 (option 3350-300)</p>  <p>xx1800002826</p> <p>For robots with protection class IP54 (option 3350-540) For robots with protection type Clean Room (option 3351-1)</p>  <p>xx1900001634</p>

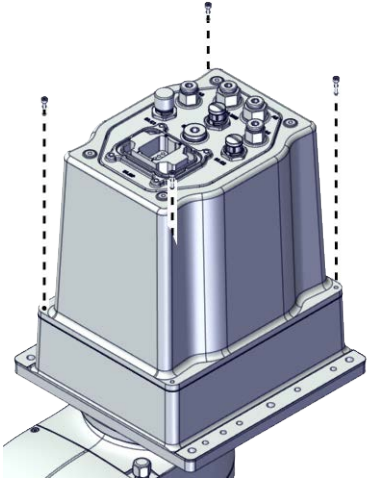
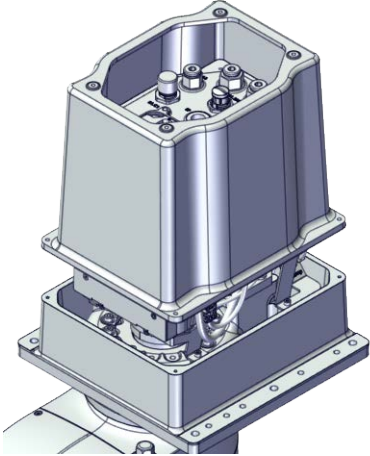
Continues on next page

	Action	Note
4	Remove the screws on the base cover to the base.	 <p>xx1800002827</p>
5	Take the base cover out.	 <p>xx1800002828</p>

Removing the casting cover of the inner arm

	Action	Note
1	 <p>DANGER</p> <p>Make sure that all supplies for electrical power, hydraulic pressure, and air pressure are turned off.</p>	
2	 <p>CAUTION</p> <p>For robots with protection type Clean Room Always cut the paint with a knife and grind the paint edge when disassembling parts of the robot! See Cut the paint or surface on the robot before replacing parts on page 118.</p>	

Continues on next page



5 Repair

5.5.1 Replacing the inner arm

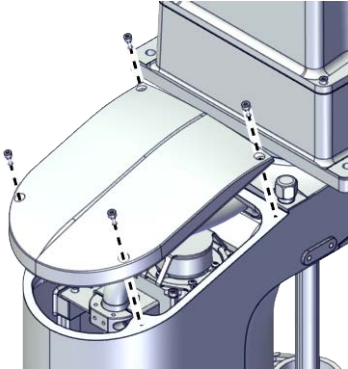
Continued

	Action	Note
3	Remove the screws.	 <p>xx1800002873</p>
4	Remove the casting cover.	

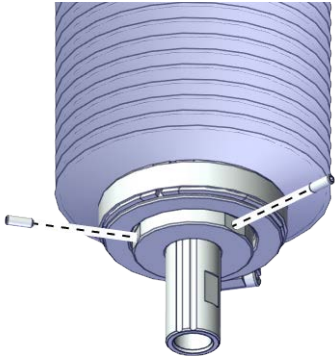

Removing the lower cover

	Action	Note
1	 DANGER Make sure that all supplies for electrical power, hydraulic pressure, and air pressure are turned off.	
2	 CAUTION For robots with protection type Clean Room Always cut the paint with a knife and grind the paint edge when disassembling parts of the robot! See Cut the paint or surface on the robot before replacing parts on page 118 .	
3	For robots with protection class IP54 (option 3350-540) For robots with protection type Clean Room (option 3351-1) Loose the locking screws.	 <p>xx1900001606</p>

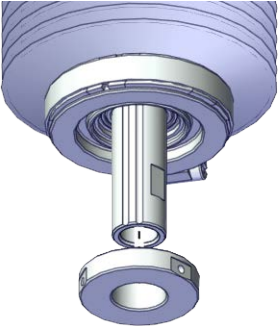
Continues on next page

	Action	Note
4	<p>For robots with protection class IP54 (option 3350-540) For robots with protection type Clean Room (option 3351-1) Remove the lower cover from the ball screw.</p>	 <p>xx1900001607</p>





Removing the cover of the outer arm

	Action	Note
1	<p> DANGER</p> <p>Make sure that all supplies for electrical power, hydraulic pressure, and air pressure are turned off.</p>	
2	<p> CAUTION</p> <p>For robots with protection type Clean Room Always cut the paint with a knife and grind the paint edge when disassembling parts of the robot! See Cut the paint or surface on the robot before replacing parts on page 118.</p>	

5 Repair

5.5.1 Replacing the inner arm

Continued

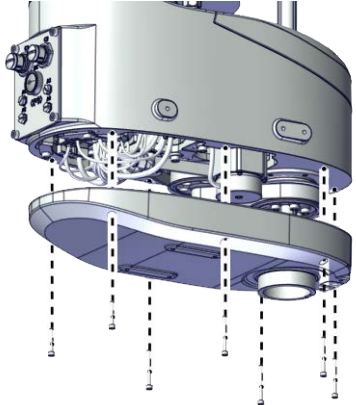
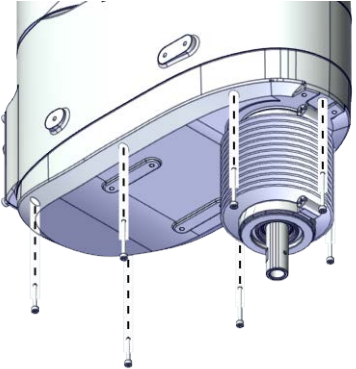
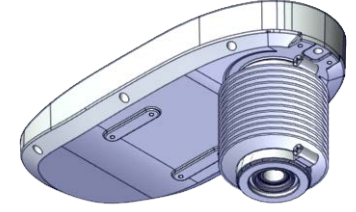
	Action	Note
3	<p>Remove the screws on the cover of the outer arm and remove the cover.</p> <p> Note</p> <p>For robots with protection class IP54 (option 3350-540) For robots with protection type Clean Room (option 3351-1) Remove the cover with bellow and housing.</p> <p> Note</p> <p>The bellow does not need to be removed separately.</p> <p> CAUTION</p> <p>There is a gasket in the cover. Be careful when removing the cover with bellow and housing.</p> <p> Tip</p> <p>Check the gasket and replace it if needed.</p>	<p>For robots with protection class IP30 (option 3350-300)</p>  <p>xx1800002836</p> <p>For robots with protection class IP54 (option 3350-540) For robots with protection type Clean Room (option 3351-1)</p>  <p>xx1900001631</p>  <p>xx1900001632</p>



Removing the cover of the inner arm

	Action	Note
1	<p> DANGER</p> <p>Make sure that all supplies for electrical power, hydraulic pressure, and air pressure are turned off.</p>	

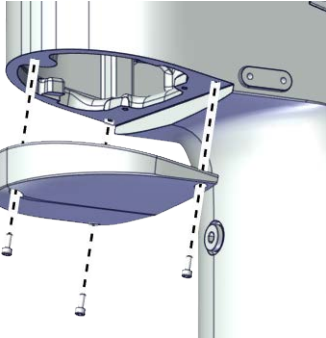
Continues on next page

	Action	Note
2	<p> CAUTION</p> <p>For robots with protection type Clean Room Always cut the paint with a knife and grind the paint edge when disassembling parts of the robot! See <i>Cut the paint or surface on the robot before replacing parts on page 118.</i></p>	
3	Remove the screws.	 <p>xx1800002899</p>
4	Remove the cover.	

Disconnecting the connectors on the base harness

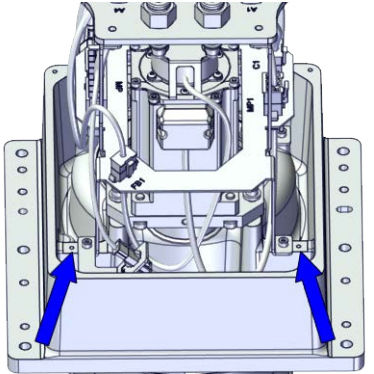
	Action	Note
1	<p> DANGER</p> <p>Make sure that all supplies for electrical power, hydraulic pressure, and air pressure are turned off.</p>	
2	<p> CAUTION</p> <p>For robots with protection type Clean Room Always cut the paint with a knife and grind the paint edge when disassembling parts of the robot! See <i>Cut the paint or surface on the robot before replacing parts on page 118.</i></p>	
3	Remove the three grounding cables from the bracket by unscrew the screws.	 <p>xx1900000062</p>

Continues on next page



5 Repair

5.5.1 Replacing the inner arm

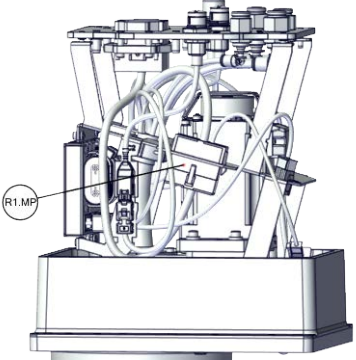



Continued

	Action	Note
4	<p>Disconnect the connector.</p> <ul style="list-style-type: none"> R1.MP <p> Tip</p> <p>Take photos of the connector and cable position before disconnecting them, to have as a reference when reconnecting.</p>	 <p>xx1800002829</p>

Disconnecting the air hoses, C1 cabling and C2 cabling (if equipped)

	Action	Note
1	<p> DANGER</p> <p>Make sure that all supplies for electrical power, hydraulic pressure, and air pressure are turned off.</p>	
2	<p> CAUTION</p> <p>For robots with protection type Clean Room</p> <p>Always cut the paint with a knife and grind the paint edge when disassembling parts of the robot! See <i>Cut the paint or surface on the robot before replacing parts on page 118.</i></p>	

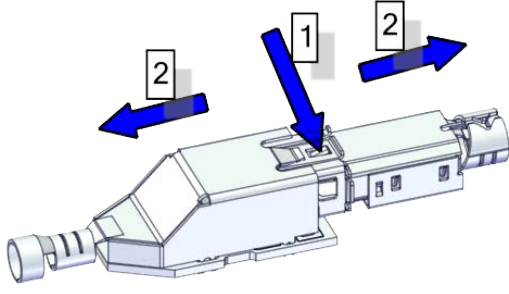
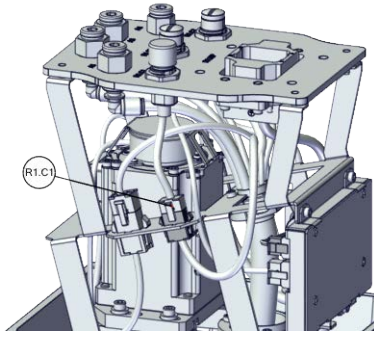
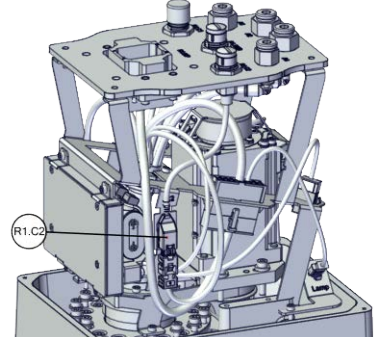
Continues on next page

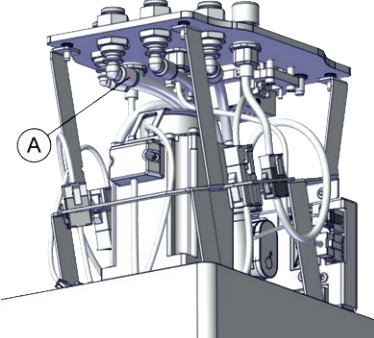
	Action	Note		
3	<p>Cut the cable straps and disconnect the connectors.</p> <ul style="list-style-type: none"> • R1.C1 • R1.C2 <p> Tip</p> <p>Take photos of the connector and cable position before disconnecting them, to have as a reference when reconnecting.</p> <p> Tip</p> <p>The connector clip has to be pressed (1) and pushed forward (2) to separate the R1.C2 (for C2 cabling).</p>  <p>xx1800002943</p>	 <p>xx1800002831</p>  <p>xx1800002832</p>		
4	<p>Disconnect the air hoses from the L-shaped connectors.</p> <p> Note</p> <p>Make sure that the air hoses are not bent or broken when you disconnect them.</p>	 <p>xx1800002830</p> <table border="1" data-bbox="1061 1612 1436 1657"> <tr> <td>A</td> <td>Air hoses</td> </tr> </table>	A	Air hoses
A	Air hoses			

Disconnecting the SMB cabling



	Action	Note
1	<p> DANGER</p> <p>Make sure that all supplies for electrical power, hydraulic pressure, and air pressure are turned off.</p>	

Continues on next page



5 Repair

5.5.1 Replacing the inner arm

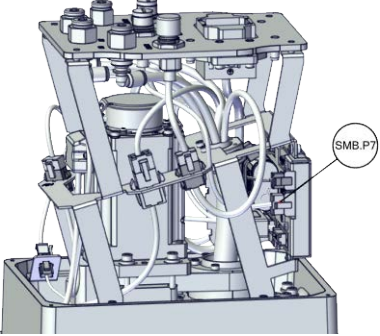
Continued

	Action	Note
2	 ELECTROSTATIC DISCHARGE (ESD) The unit is sensitive to ESD. Before handling the unit read the safety information in section The unit is sensitive to ESD on page 45 .	
3	 CAUTION For robots with protection type Clean Room Always cut the paint with a knife and grind the paint edge when disassembling parts of the robot! See Cut the paint or surface on the robot before replacing parts on page 118 .	
4	Disconnect the connectors. <ul style="list-style-type: none"> • SMB.P7 • SMB.J1 (Only when the internal harness)  Tip Take photos of the connector and cable position before disconnecting them, to have as a reference when reconnecting.	 <p>xx1800002833</p>



Removing the base harness

	Action	Note
1	 DANGER Make sure that all supplies for electrical power, hydraulic pressure, and air pressure are turned off.	
2	 CAUTION For robots with protection type Clean Room Always cut the paint with a knife and grind the paint edge when disassembling parts of the robot! See Cut the paint or surface on the robot before replacing parts on page 118 .	

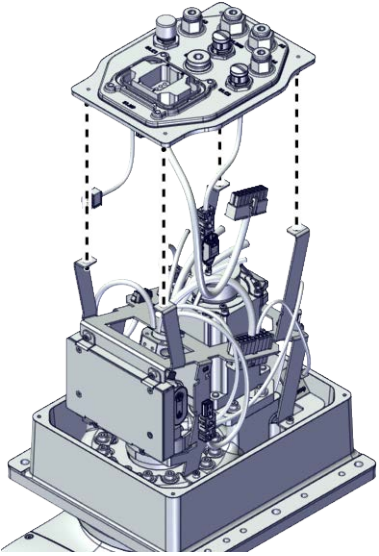
Continues on next page

	Action	Note
3	Remove the base harness from the bracket.	 <p>xx1800002834</p>

Removing the bracket

	Action	Note
1	 <p>DANGER</p> <p>Make sure that all supplies for electrical power, hydraulic pressure, and air pressure are turned off.</p>	
2	 <p>CAUTION</p> <p>For robots with protection type Clean Room Always cut the paint with a knife and grind the paint edge when disassembling parts of the robot! See Cut the paint or surface on the robot before replacing parts on page 118.</p>	

Continues on next page

5 Repair

5.5.1 Replacing the inner arm

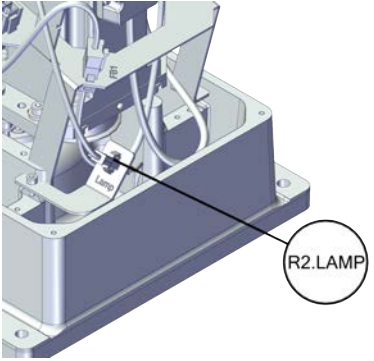
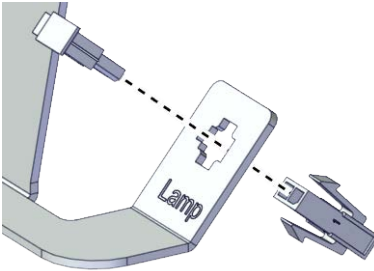
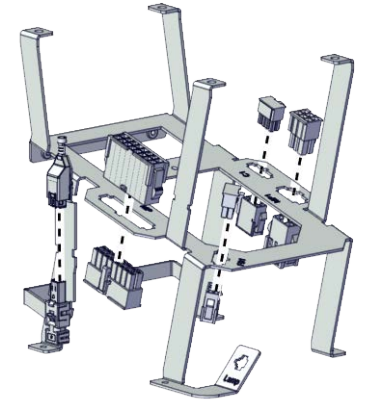
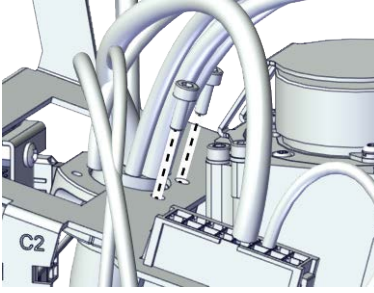

Continued

	Action	Note
3	Disconnect the lamp connector on the bracket.	 <p>xx1800002867</p>  <p>xx1900000079</p>
4	Snap loose and remove the female head of the connectors from the bracket.	 <p>xx1900000081</p>
5	Release the cable ferrule from the bracket.	 <p>xx1900000080</p>

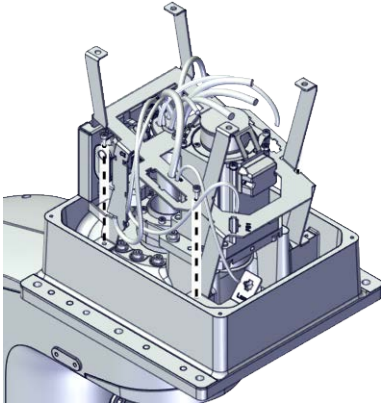
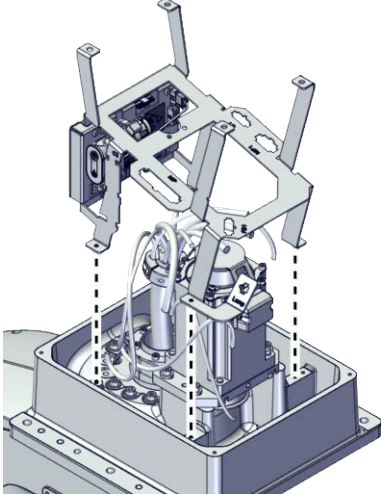
Continues on next page

	Action	Note
6	Remove the screws on the bracket.	 <p>xx1800002868</p>
7	Remove the bracket.	 <p>xx1800002869</p>

Removing the axis-1 motor sub-assembly

	Action	Note
1	 <p>DANGER</p> <p>Make sure that all supplies for electrical power, hydraulic pressure, and air pressure are turned off.</p>	
2	 <p>CAUTION</p> <p>For robots with protection type Clean Room Always cut the paint with a knife and grind the paint edge when disassembling parts of the robot! See Cut the paint or surface on the robot before replacing parts on page 118.</p>	

Continues on next page



5 Repair

5.5.1 Replacing the inner arm

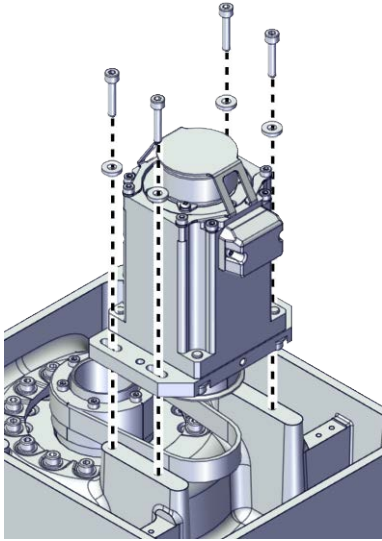
Continued

	Action	Note
3	Remove the screws and washers.	 <p>xx1800002870</p>
4	Remove the motor and the timing belt.	

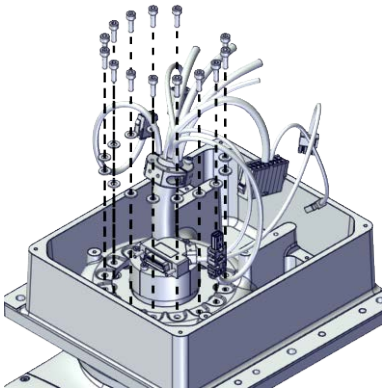

Removing the base

	Action	Note
1	 DANGER Make sure that all supplies for electrical power, hydraulic pressure, and air pressure are turned off.	
2	 CAUTION For robots with protection type Clean Room Always cut the paint with a knife and grind the paint edge when disassembling parts of the robot! See Cut the paint or surface on the robot before replacing parts on page 118.	
3	Remove the screws and washers.	 <p>xx1800002851</p>

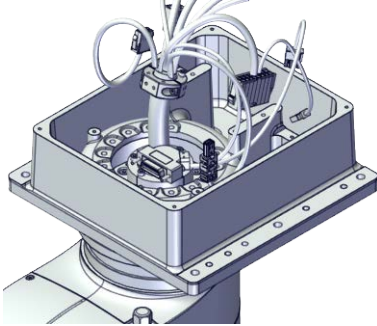
Continues on next page

	Action	Note
4	Remove the base.	 <p>xx1800002852</p>

Removing the bracket for the process hub

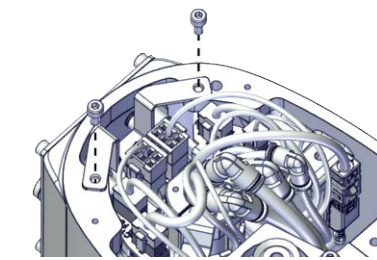
	Action	Note
1	 DANGER Make sure that all supplies for electrical power, hydraulic pressure, and air pressure are turned off.	
2	 CAUTION For robots with protection type Clean Room Always cut the paint with a knife and grind the paint edge when disassembling parts of the robot! See Cut the paint or surface on the robot before replacing parts on page 118.	
3	Remove the screws on the bracket and take it out carefully.	 <p>xx1800002839</p>

Disconnecting the connectors for axis-3 motor

	Action	Note
1	 DANGER Make sure that all supplies for electrical power, hydraulic pressure, and air pressure are turned off.	

Continues on next page



5 Repair

5.5.1 Replacing the inner arm

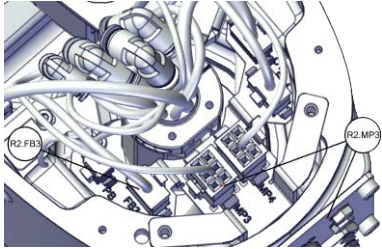
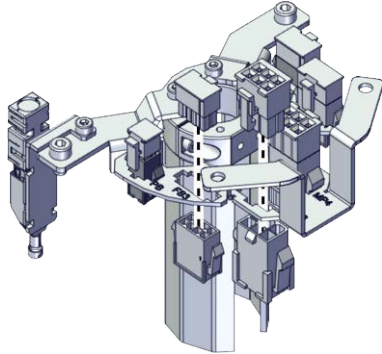
Continued

	Action	Note
2	 CAUTION For robots with protection type Clean Room Always cut the paint with a knife and grind the paint edge when disassembling parts of the robot! See Cut the paint or surface on the robot before replacing parts on page 118 .	
3	Disconnect the connectors. <ul style="list-style-type: none"> • R2.MP3 • R2.FB3 	 xx190000063
4	Snap loose and remove the female head of the connectors from the bracket.	 xx190000064



Disconnecting the connectors for axis-4 motor

	Action	Note
1	 DANGER Make sure that all supplies for electrical power, hydraulic pressure, and air pressure are turned off.	
2	 CAUTION For robots with protection type Clean Room Always cut the paint with a knife and grind the paint edge when disassembling parts of the robot! See Cut the paint or surface on the robot before replacing parts on page 118 .	

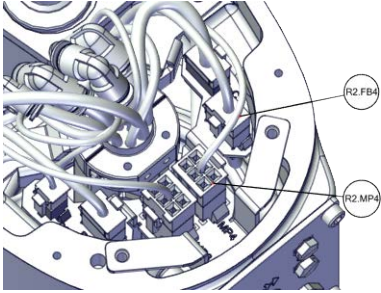
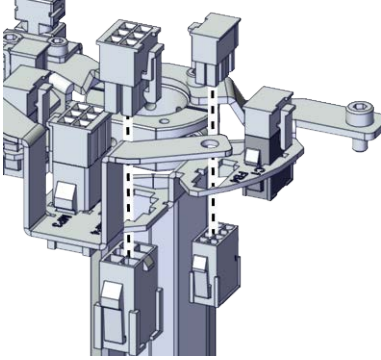
Continues on next page

	Action	Note
3	Disconnect the connectors. <ul style="list-style-type: none"> • R2.MP4 • R2.FB4 	 <p>xx1900000065</p>
4	Snap loose and remove the female head of the connectors from the bracket.	 <p>xx1900000066</p>

Disconnecting the connector for PB

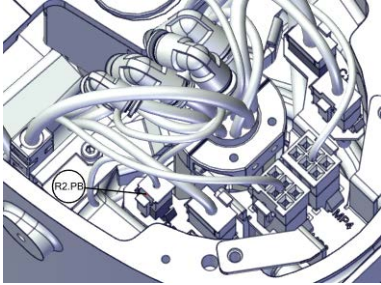
	Action	Note
1	 <p>DANGER</p> <p>Make sure that all supplies for electrical power, hydraulic pressure, and air pressure are turned off.</p>	
2	 <p>CAUTION</p> <p>For robots with protection type Clean Room Always cut the paint with a knife and grind the paint edge when disassembling parts of the robot! See Cut the paint or surface on the robot before replacing parts on page 118.</p>	
3	Disconnect the connector. <ul style="list-style-type: none"> • R2.PB 	 <p>xx1900000068</p>

Continues on next page



5 Repair

5.5.1 Replacing the inner arm

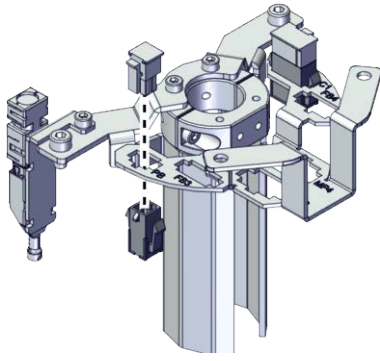

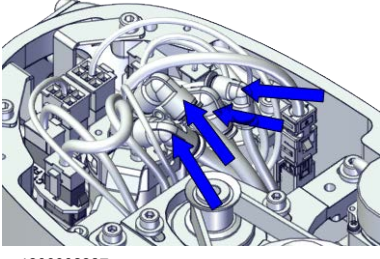

Continued

	Action	Note
4	Snap loose and remove the female head of the connector from the bracket.	 <p>xx190000069</p>

Disconnecting the air hoses, C1 cabling and C2 cabling (if equipped)

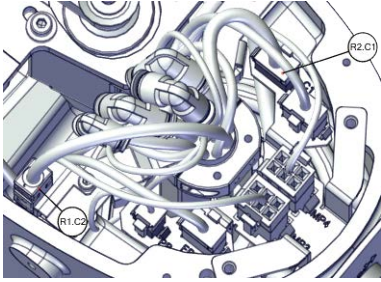
	Action	Note
1	 DANGER Make sure that all supplies for electrical power, hydraulic pressure, and air pressure are turned off.	
2	 CAUTION For robots with protection type Clean Room Always cut the paint with a knife and grind the paint edge when disassembling parts of the robot! See Cut the paint or surface on the robot before replacing parts on page 118 .	
3	Disconnect the air hoses from the L-shaped connectors.	 <p>xx1800002837</p>

Continues on next page

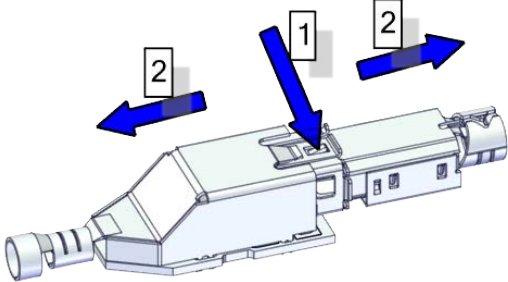
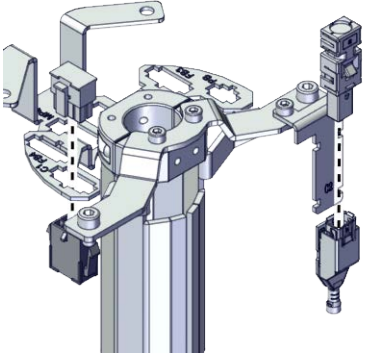
	Action	Note
4	<p>For robots with C1 cabling</p> <p>Disconnect the connector.</p> <ul style="list-style-type: none"> • R2.C1 	
5	<p>For robots with C2 cabling</p> <p>Disconnect the connector.</p> <ul style="list-style-type: none"> • R1.C2 <p> Tip</p> <p>Cut the cable straps for the R1.C2 at the same time.</p> <p> Tip</p> <p>Take photos of the connector and cable position before disconnecting them, to have as a reference when reconnecting.</p> <p> Tip</p> <p>The connector clip has to be pressed (1) and pushed forward (2) to separate the R1.C2 (for C2 cabling).</p> 	<p>xx1900000070</p>
6	<p>Snap loose and remove the female head of the connectors from the bracket.</p>	 <p>xx1900000071</p>





Continues on next page

5 Repair

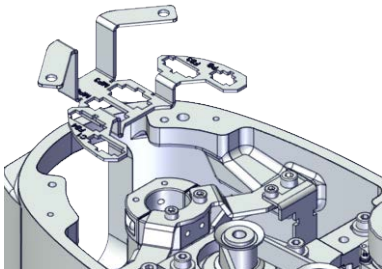

5.5.1 Replacing the inner arm

Continued

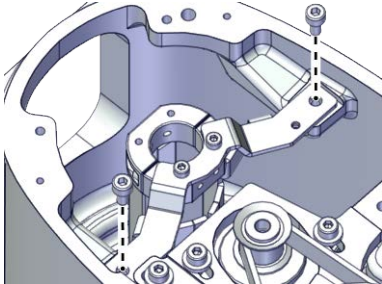
Removing the cable ferrule, bracket and protected bracket

	Action	Note
1	 DANGER Make sure that all supplies for electrical power, hydraulic pressure, and air pressure are turned off.	
2	 CAUTION For robots with protection type Clean Room Always cut the paint with a knife and grind the paint edge when disassembling parts of the robot! See Cut the paint or surface on the robot before replacing parts on page 118 .	
3	Take out the bracket from the outer arm.  Note The harness are not visible due to the cleanness requirements of the illustration. They are still existing inside the cable ferrule in the actual situation.	 xx190000073
4	Remove the screws on the protected bracket.  Note The harness are not visible due to the cleanness requirements of the illustration. They are still existing inside the cable ferrule in the actual situation.	 xx190000074

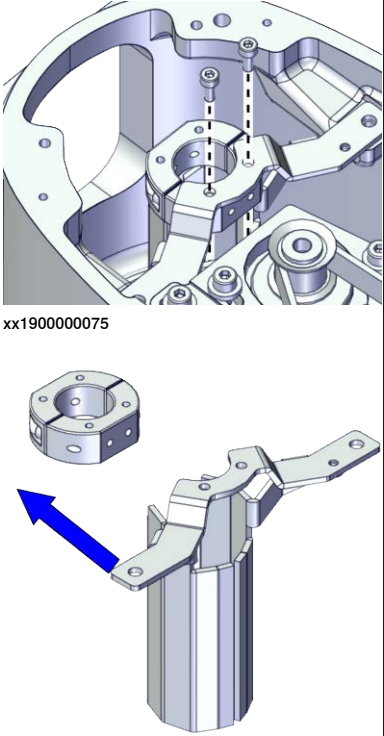
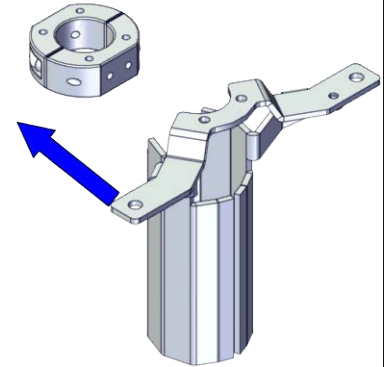
Continues on next page

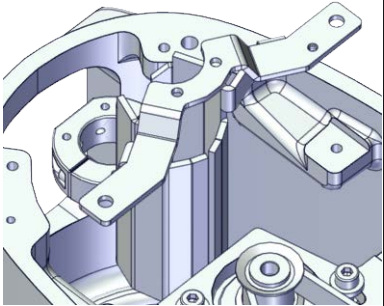
	Action	Note
5	<p>Remove the screws on the protected bracket to the cable ferrule to release the cable ferrule with cable.</p> <p> Note</p> <p>The harness are not visible due to the cleanness requirements of the illustration. They are still existing inside the cable ferrule in the actual situation.</p>	 <p>xx190000075</p> <p>xx190000076</p>
6	<p>Remove the protected bracket.</p> <p> Tip</p> <p>Pull the protected bracket to the ball screw side to push the cable with the cable ferrule out from the protected bracket.</p> <p> Note</p> <p>The harness are not visible due to the cleanness requirements of the illustration. They are still existing inside the cable ferrule in the actual situation.</p>	 <p>xx190000078</p>

Continues on next page



5 Repair

5.5.1 Replacing the inner arm

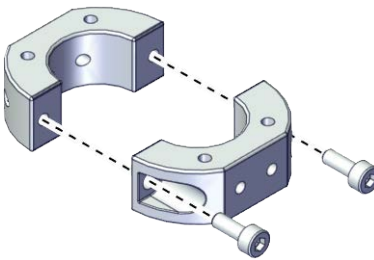

Continued

	Action	Note
7	Remove the screws on the cable ferrule and take the cable ferrule out.	 <p>xx1800002842</p> <p>xx1800002849</p>

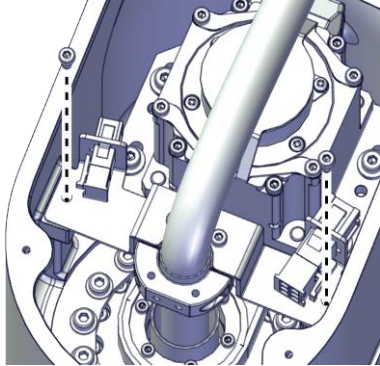

Removing the cable bracket at the axis -2 motor position in the inner arm

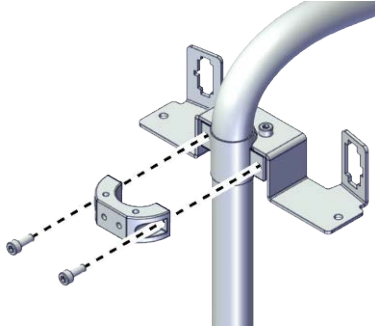
	Action	Note
1	 <p>DANGER</p> <p>Make sure that all supplies for electrical power, hydraulic pressure, and air pressure are turned off.</p>	
2	 <p>CAUTION</p> <p>For robots with protection type Clean Room Always cut the paint with a knife and grind the paint edge when disassembling parts of the robot! See Cut the paint or surface on the robot before replacing parts on page 118.</p>	
3	Remove the screws.	 <p>xx1800002874</p>

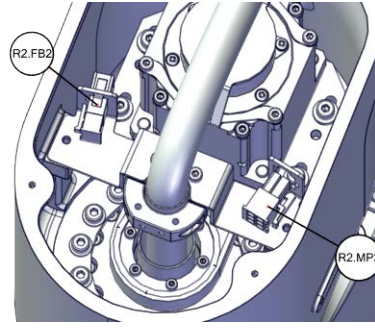
Continues on next page

	Action	Note
4	Remove the screws on the cable ferrule to release the cable.	 <p>xx1800002876</p>
5	Disconnect the connectors. <ul style="list-style-type: none"> • R2.MP2 • R2.FB2  Tip Take photos of the connector and cable position before disconnecting them, to have as a reference when reconnecting.	 <p>xx1800002875</p>

Removing the internal harness from the axis -2 gearbox position



	Action	Note
1	 DANGER Make sure that all supplies for electrical power, hydraulic pressure, and air pressure are turned off.	
2	 CAUTION For robots with protection type Clean Room Always cut the paint with a knife and grind the paint edge when disassembling parts of the robot! See Cut the paint or surface on the robot before replacing parts on page 118 .	
3	Cut the cable straps for R2.MP3 and R2.MP4.  Tip Take photos of the cable straps position before cutting them, to have as a reference when routing the cable.	

Continues on next page



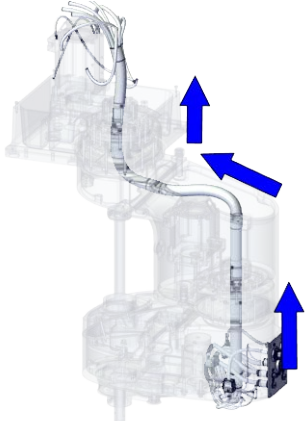

5 Repair

5.5.1 Replacing the inner arm

Continued



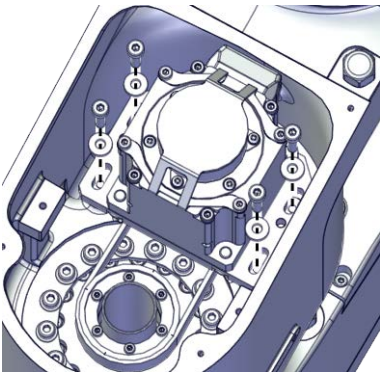

	Action	Note
4	<p>Pull the internal harness out of the outer arm from the centre of the axis-2 gearbox.</p> <p> Tip</p> <p>Wrap the connectors with the masking tape.</p> <p> Tip</p> <p>Take photos of the connector and cable position before disconnecting them, to have as a reference when reconnecting.</p>	 <p>xx1800003411</p>

Removing the axis-2 motor sub-assembly

	Action	Note
1	<p> DANGER</p> <p>Make sure that all supplies for electrical power, hydraulic pressure, and air pressure are turned off.</p>	
2	<p> CAUTION</p> <p>For robots with protection type Clean Room</p> <p>Always cut the paint with a knife and grind the paint edge when disassembling parts of the robot! See Cut the paint or surface on the robot before replacing parts on page 118.</p>	
3	Remove the screws and washers.	 <p>xx1800002877</p>
4	<p>Remove the motor and the timing belt.</p> <p> Tip</p> <p>Move the internal harness out of the way.</p>	

Continues on next page

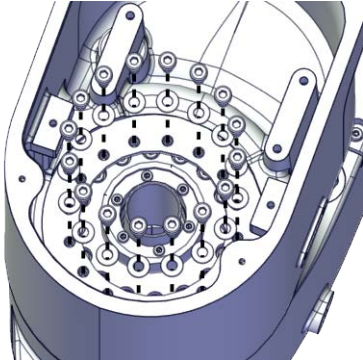
Separating the outer arm from the inner arm

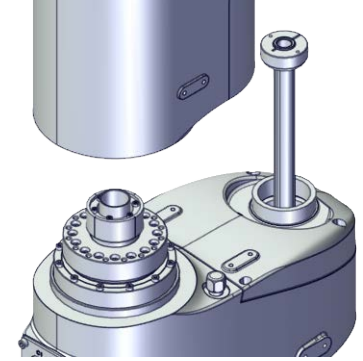
	Action	Note
1	 DANGER Make sure that all supplies for electrical power, hydraulic pressure, and air pressure are turned off.	
2	 CAUTION For robots with protection type Clean Room Always cut the paint with a knife and grind the paint edge when disassembling parts of the robot! See Cut the paint or surface on the robot before replacing parts on page 118 .	
3	Remove the screws and washers.	 xx1800003382
4	Remove the outer arm with the axis-2 gear unit assembly from the inner arm.  Tip Move the internal harness out of the way.	 xx1800003383

Removing the bracket at the axis -1 gearbox position in the inner arm

	Action	Note
1	 DANGER Make sure that all supplies for electrical power, hydraulic pressure, and air pressure are turned off.	

Continues on next page

5 Repair

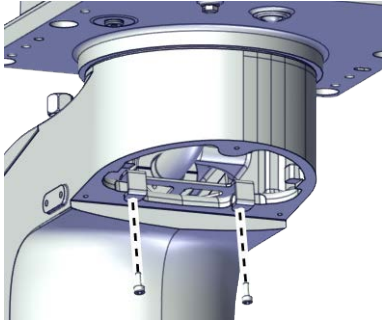
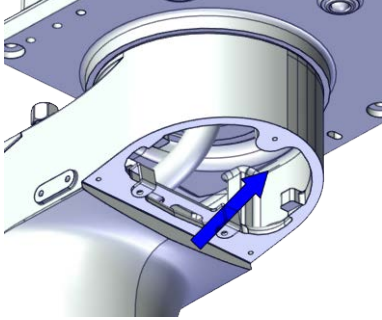
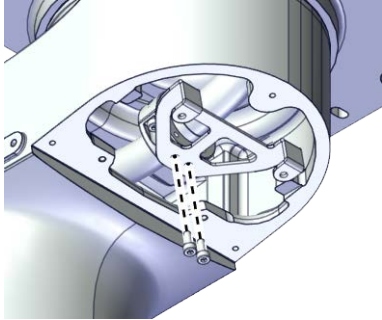

5.5.1 Replacing the inner arm

Continued



	Action	Note
2	<p> CAUTION</p> <p>For robots with protection type Clean Room Always cut the paint with a knife and grind the paint edge when disassembling parts of the robot! See <i>Cut the paint or surface on the robot before replacing parts on page 118.</i></p>	
3	Remove the screws.	 xx1800003408
4	Remove the bracket from the inner arm and take it out with the cable slightly.	 xx1900000099 <i>Figure 5.2:</i>
5	Remove the bracket from the cable ferrule by removing the screws.	 xx1800003409

Continues on next page

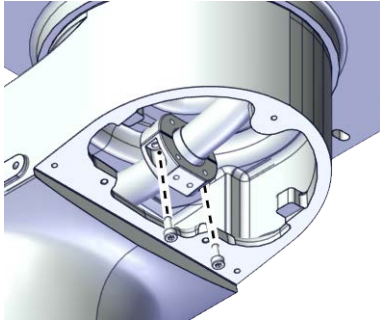
Removing the cable ferrule at the axis -1 gearbox position in the inner arm

	Action	Note
1	 DANGER Make sure that all supplies for electrical power, hydraulic pressure, and air pressure are turned off.	
2	 CAUTION For robots with protection type Clean Room Always cut the paint with a knife and grind the paint edge when disassembling parts of the robot! See Cut the paint or surface on the robot before replacing parts on page 118 .	
3	Remove the screws.	 xx1800003410
4	Remove the cable ferrule on the cable and take it out.	

Removing the cable ferrule in the base

	Action	Note
1	 DANGER Make sure that all supplies for electrical power, hydraulic pressure, and air pressure are turned off.	
2	 CAUTION For robots with protection type Clean Room Always cut the paint with a knife and grind the paint edge when disassembling parts of the robot! See Cut the paint or surface on the robot before replacing parts on page 118 .	

Continues on next page



5 Repair

5.5.1 Replacing the inner arm

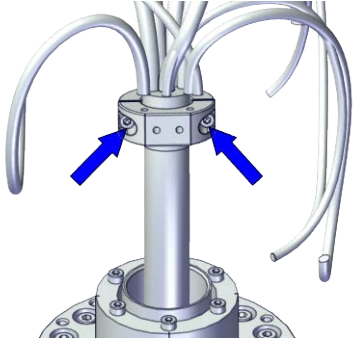
Continued



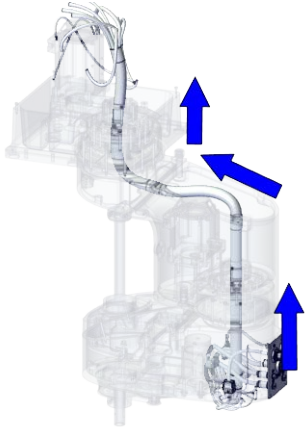

	Action	Note
3	Remove the screws.	 <p>xx1800002900</p>
4	Remove the cable ferrule on the cable.	

Removing the internal harness from the inner arm

	Action	Note
1	 DANGER Make sure that all supplies for electrical power, hydraulic pressure, and air pressure are turned off.	
2	 CAUTION For robots with protection type Clean Room Always cut the paint with a knife and grind the paint edge when disassembling parts of the robot! See Cut the paint or surface on the robot before replacing parts on page 118 .	
3	Pull the internal harness out of the inner arm from the sleeve of the axis-1 gearbox.  Tip Wrap the connectors with the masking tape.	 <p>xx1800003411</p>

Continues on next page

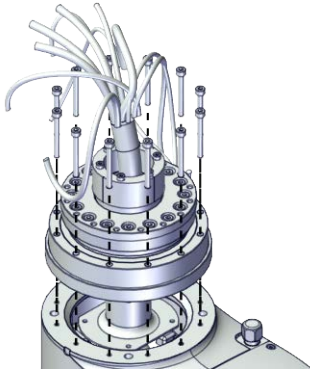

Removing the axis-1 gear unit sub-assembly from the inner arm

	Action	Note
1	 DANGER Make sure that all supplies for electrical power, hydraulic pressure, and air pressure are turned off.	
2	 CAUTION For robots with protection type Clean Room Always cut the paint with a knife and grind the paint edge when disassembling parts of the robot! See Cut the paint or surface on the robot before replacing parts on page 118 .	
3	Remove the screws.	 <small>xx1800003379</small>
4	Remove the axis-1 gear unit sub-assembly through the cable slightly.  Tip Wrap the connectors with the masking tape.	

Refitting the inner arm

Use these procedures to refit the inner arm.

Refitting the axis-1 gear unit sub-assembly



	Action	Note
1	For robots with protection type Clean Room: Clean the joints that have been opened and wipe the parts free from particles with spirit on a lint free. See Cut the paint or surface on the robot before replacing parts on page 118  Note After all repair work, wipe the Clean Room robot free from particles with spirit on a lint free cloth.	
2	 CAUTION Whenever parting/mating motor and gearbox, the gears may be damaged if excessive force is used.	

Continues on next page

5 Repair

5.5.1 Replacing the inner arm

Continued

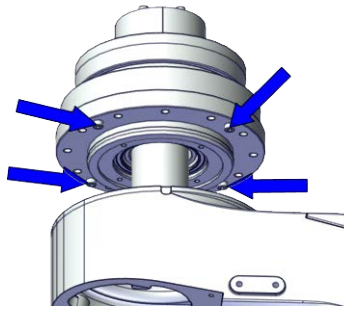
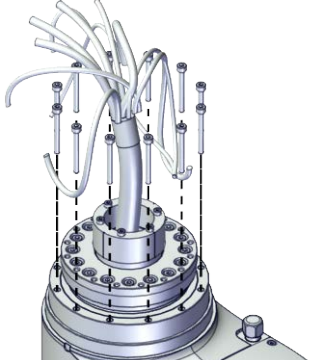
	Action	Note
3	<p>Refit the gear unit according to the location pin through the cable.</p> <p> Tip</p> <p>When the gear unit is in the right position, you can hear a clear "Click".</p> <p> Tip</p> <p>Wrap the connectors with the masking tape.</p>	 <p>xx1800003380</p>
4	<p>Refit the screws.</p>	<p>Screws: Hex socket head cap screw M4x35 12.9 Lafre 2C2B/FC6.9 (12 pcs)</p> <p>Tightening torque: 0.5 Nm-1 Nm-2 Nm-4.5 Nm ±10%</p>  <p>xx1800003381</p>



Refitting the base

	Action	Note
1	<p>For robots with protection type Clean Room: Clean the joints that have been opened and wipe the parts free from particles with spirit on a lint free. See Cut the paint or surface on the robot before replacing parts on page 118</p> <p> Note</p> <p>After all repair work, wipe the Clean Room robot free from particles with spirit on a lint free cloth.</p>	

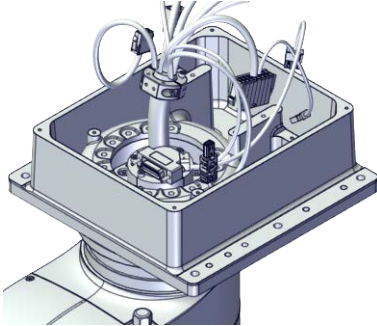
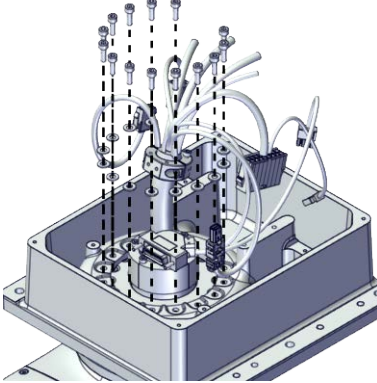
Continues on next page

	Action	Note
2	Refit the base to the axis-1 gearbox as the illustration.	 <p>xx1800002852</p>
3	Refit the screws.	<p>Screws: Hex socket head cap screw M4x12 12.9 Lafre 2C2B/FC6.9 (14 pcs) Tightening torque: 0.5 Nm-1 Nm-2 Nm-4 Nm $\pm 10\%$</p>  <p>xx1800002851</p>

Refitting the outer arm to the inner arm

	Action	Note
1	<p>For robots with protection type Clean Room: Clean the joints that have been opened and wipe the parts free from particles with spirit on a lint free. See Cut the paint or surface on the robot before replacing parts on page 118</p> <p> Note</p> <p>After all repair work, wipe the Clean Room robot free from particles with spirit on a lint free cloth.</p>	
2	<p> CAUTION</p> <p>Whenever parting/mating motor and gearbox, the gears may be damaged if excessive force is used.</p>	

Continues on next page

5 Repair

5.5.1 Replacing the inner arm

Continued

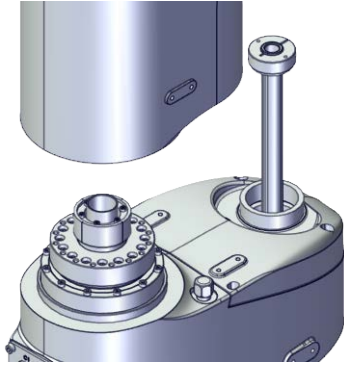
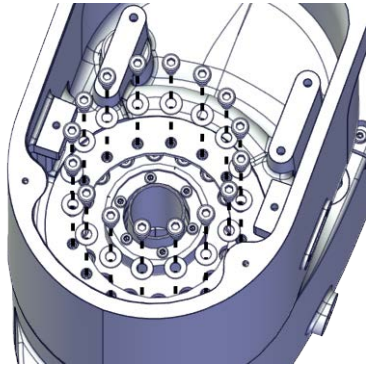
	Action	Note
3	<p>Refit the outer arm with the gear unit to the inner arm. (Location pin?)</p> <p> Tip</p> <p>When the gear unit is in the right position, you can hear a clear "Click".</p>	 <p>xx1800003383</p>
4	<p>Refit the screws.</p>	<p>Screws: Hex socket head cap screw M4x12 12.9 Lafre 2C2B/FC6.9 (16 pcs)</p> <p>Washers: Spring washer 9x4.3x1 Steel (16 pcs)</p> <p>Tightening torque: 0.5 Nm-1 Nm-2 Nm-4.5 Nm $\pm 10\%$</p>  <p>xx1800003382</p>



Refitting the axis-1 motor sub-assembly

	Action	Note
1	<p>For robots with protection type Clean Room: Clean the joints that have been opened and wipe the parts free from particles with spirit on a lint free. See Cut the paint or surface on the robot before replacing parts on page 118</p> <p> Note</p> <p>After all repair work, wipe the Clean Room robot free from particles with spirit on a lint free cloth.</p>	

Continues on next page

5.5.1 Replacing the inner arm

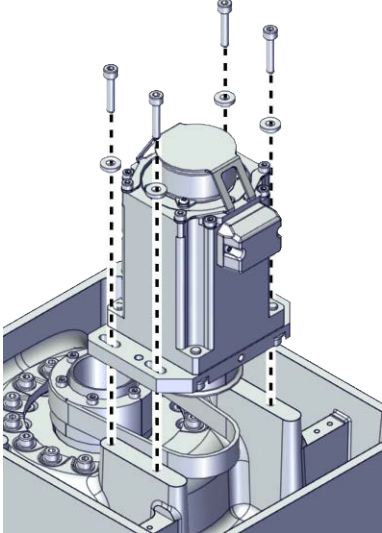
Continued

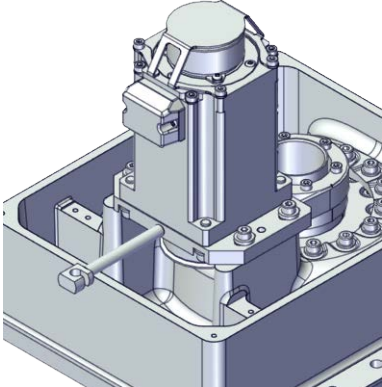
	Action	Note	
2	Refit the timing belt to the pulley.	Screws: Hex socket head cap screw M4x20 12.9 Lafre 2C2B/FC6.9 (4 pcs)	
3	Refit the motor.		
4	Refit the timing belt to the motor. Ensure that the belt runs correctly in the grooves.		Washers: Washer 4.3x10x2 steel (4 pcs)
5	Refit the screws and washers without fully tightened.	Tightening torque: 3 Nm \pm 10%  xx1800002870 Timing belt: 3HAC061864-001	
6	Install the axis1&2 belt tension adjustment tool to the motor.  Note Just tighten the tool.	Belt tension adjustment tool set, axis 1&2:-  xx1900000093	

Continues on next page

5 Repair

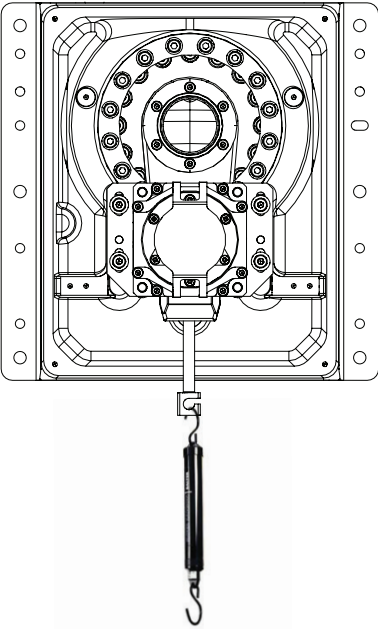
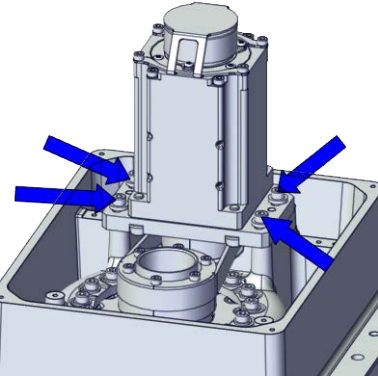

5.5.1 Replacing the inner arm

Continued

	Action	Note
7	<p>Use a handheld dynamometer hooking to the special tool and pull the dynamometer to make the tension falling in the allowed force range.</p> <p> Note</p> <p>During the measurement, make sure that all interferences that may affect the force are removed. Pay attention to the force application direction.</p>	<p>Used belt: 70-80N New belt:100-110N</p>  <p>xx1900000094</p>
8	<p>Fasten the screws to the recommended tightening torque.</p>	<p>Tightening torque: 3 Nm \pm10%</p>  <p>xx1800002871</p>
9	<p>Use a sonic tension meter to measure the timing belt tension.</p>	<p>Used belt: 250-305Hz New belt:296-378Hz</p>
10	<p>If the timing belt tension does not meet the requirement, loosen the motor screws and readjust.</p>	

Continues on next page

Refitting the axis-2 motor sub-assembly

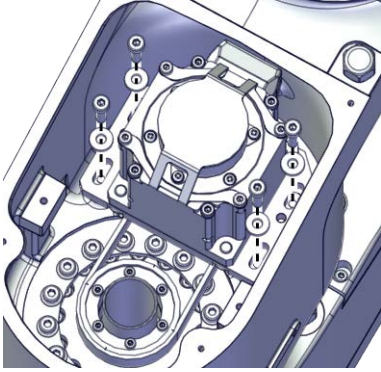
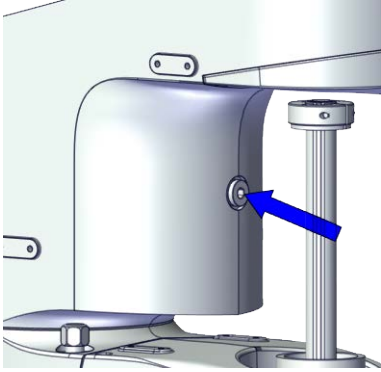

	Action	Note
1	<p>For robots with protection type Clean Room: Clean the joints that have been opened and wipe the parts free from particles with spirit on a lint free. See Cut the paint or surface on the robot before replacing parts on page 118</p> <p> Note</p> <p>After all repair work, wipe the Clean Room robot free from particles with spirit on a lint free cloth.</p>	
2	<p>Refit the axis-2 timing belt onto the pulley on the axis-2 gearbox.</p>	<p>Screws: Hex socket head cap screw M4x20 12.9 Lafre 2C2B/FC6.9 (4 pcs)</p>
3	<p>Refit the motor and refit the timing belt to the motor. Ensure that the belt runs correctly in the grooves.</p> <p> Tip</p> <p>Move the internal harness out of the way.</p>	<p>Washers: Washer 4.3x10x2 steel (4 pcs)</p> <p>Tightening torque: 3 Nm ±10%</p> 
4	<p>Refit the screws and washers without fully tightened.</p>	<p>xx1800002877</p> <p>Timing belt: 3HAC061861-001</p>
5	<p>Remove the plug.</p>	 <p>xx1800002878</p>

Continues on next page

5 Repair

5.5.1 Replacing the inner arm

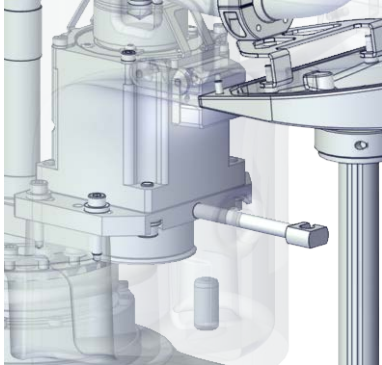
Continued

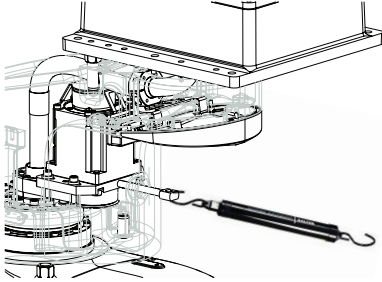
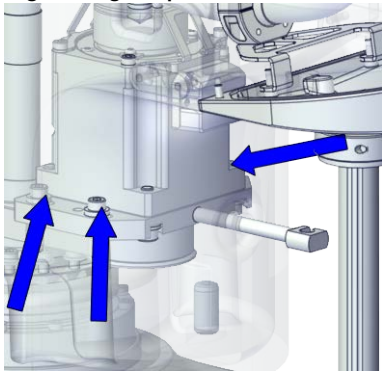
	Action	Note
6	<p>Install the axis-1&2 belt tension adjustment tool to the motor through the hole.</p> <p> Note</p> <p>Just tighten the tool.</p>	<p>Belt tension adjustment tool set, axis 1&2:-</p>  <p>xx1800002879</p>
7	<p>Use a handheld dynamometer hooking to the screw and pull the dynamometer to make the tension falling in the allowed force range.</p> <p> Note</p> <p>During the measurement, make sure that all interferences that may affect the force are removed. Pay attention to the force application direction.</p> <p> Tip</p> <p>If the ball screw will interfere with the handheld dynamometer, adjust the ball screw manually.</p>	<p>Used belt: 45-51N New belt:65-71N</p>  <p>xx1900000095</p>
8	<p>Fasten the screws to the recommended tightening torque.</p>	<p>Tightening torque: 3 Nm \pm10%</p>  <p>xx1800002880</p>
9	<p>Use a sonic tension meter to measure the timing belt tension.</p>	<p>Used belt: 193-236Hz New belt:229-293Hz</p>
10	<p>If the timing belt tension does not meet the requirement, loosen the motor screws and readjust.</p>	
11	<p>Remove the axis-1&2 belt tension adjustment tool.</p>	

Continues on next page

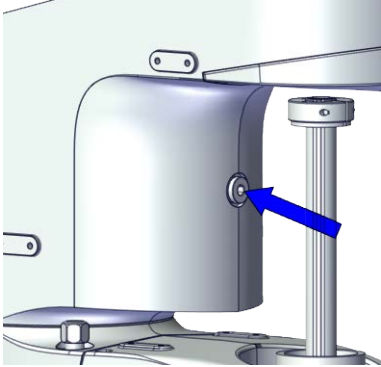
	Action	Note
12	<p>Refit the plug.</p> <p> Tip Just tighten it.</p>	<p>Tightening torque: 2 Nm ±10%</p>  <p>xx1800002878</p>

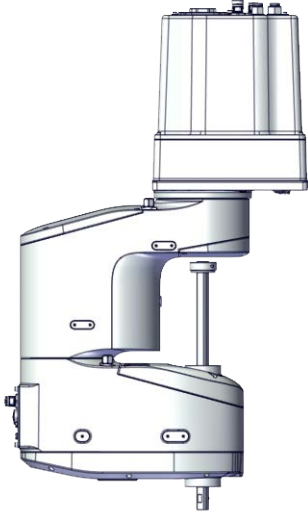

Inserting the internal harness through the inner arm

	Action	Note
1	<p>For robots with protection type Clean Room: Clean the joints that have been opened and wipe the parts free from particles with spirit on a lint free. See Cut the paint or surface on the robot before replacing parts on page 118</p> <p> Note After all repair work, wipe the Clean Room robot free from particles with spirit on a lint free cloth.</p>	
2	<p>Make sure that the robot is at zero position.</p>	 <p>xx1800002825</p>



5 Repair

5.5.1 Replacing the inner arm

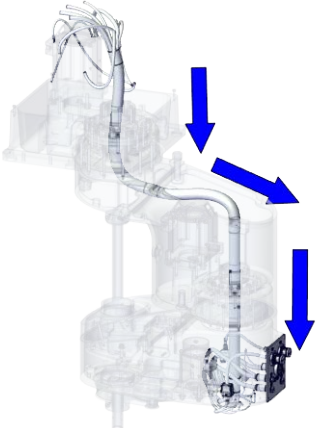
Continued

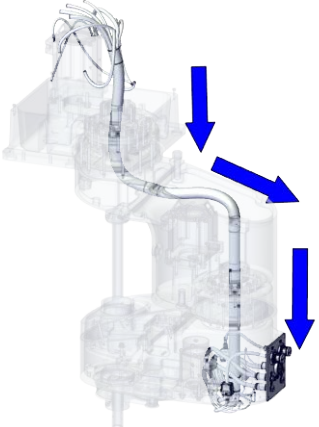

	Action	Note
3	<p>Insert the internal harness into the inner arm through the sleeve of the axis-1 gearbox from the base.</p> <p> Tip Wrap the connectors with the masking tape.</p> <p> Tip The air hoses should face the axis-1 motor.</p> <p> CAUTION Make sure that no cables or hoses are twisted or strained. Reroute if necessary.</p>	 <p>xx1800003412</p>

Inserting the internal harness through the axis -2 gearbox position

	Action	Note
1	<p>For robots with protection type Clean Room: Clean the joints that have been opened and wipe the parts free from particles with spirit on a lint free. See Cut the paint or surface on the robot before replacing parts on page 118</p> <p> Note After all repair work, wipe the Clean Room robot free from particles with spirit on a lint free cloth.</p>	
2	<p>Insert the internal harness into the outer arm through the centre of the axis-2 gearbox.</p> <p> Tip Wrap the connectors with the masking tape.</p>	 <p>xx1800003412</p>
3	Secure the R2.MP3 and R2.MP4 with cable straps.	

Continues on next page

Refitting the cable ferrule in the base

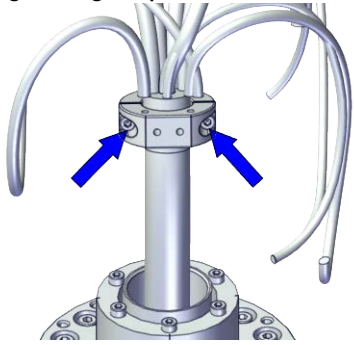
	Action	Note
1	<p>For robots with protection type Clean Room: Clean the joints that have been opened and wipe the parts free from particles with spirit on a lint free. See Cut the paint or surface on the robot before replacing parts on page 118</p> <p> Note</p> <p>After all repair work, wipe the Clean Room robot free from particles with spirit on a lint free cloth.</p>	
2	<p>Refit the cable ferrule to the cable and secure it with the screw.</p> <p> Tip</p> <p>The cable ferrule should be refitted at the position Where the tape is wrapped.</p> <p> Tip</p> <p>Align all the cable ferrules so that the cable is in a natural bending position to avoid twisting.</p>	<p>Screws: Hex socket head cap screw M3x5 12.9 Lafre 2C2B/FC6.9 (2 pcs) Tightening torque: 1.5 Nm \pm10%</p>  <p>xx1800002900</p>

Refitting the cable ferrule at the axis -1 gearbox position in the inner arm



	Action	Note
1	<p>For robots with protection type Clean Room: Clean the joints that have been opened and wipe the parts free from particles with spirit on a lint free. See Cut the paint or surface on the robot before replacing parts on page 118</p> <p> Note</p> <p>After all repair work, wipe the Clean Room robot free from particles with spirit on a lint free cloth.</p>	
2	<p>Lay the internal harness in a natural state without distortion.</p>	

Continues on next page

5 Repair

5.5.1 Replacing the inner arm

Continued

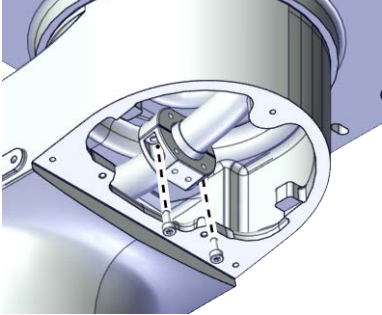
	Action	Note
3	<p>Refit the cable ferrule on the cable at the marked position and secure with screws.</p> <p> Tip</p> <p>The position with wrapped tape is the marked position for the cable ferrule.</p> <p> Tip</p> <p>Align all the cable ferrules so that the cable is in a natural bending position to avoid twisting.</p>	<p>Screws: Hex socket head cap screw M3x8 12.9 Lafre 2C2B/FC6.9 (2 pcs)</p> <p>Tightening torque: 1.5 Nm \pm10%</p>  <p>xx1800003410</p>

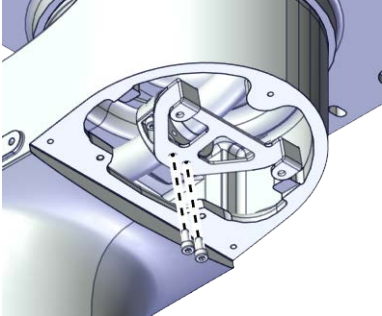

Refitting the bracket at the axis -1 gearbox position in the inner arm

	Action	Note
1	<p>For robots with protection type Clean Room: Clean the joints that have been opened and wipe the parts free from particles with spirit on a lint free. See Cut the paint or surface on the robot before replacing parts on page 118</p> <p> Note</p> <p>After all repair work, wipe the Clean Room robot free from particles with spirit on a lint free cloth.</p>	
2	<p>Refit the cable ferrule to the bracket and secure with the screws.</p>	<p>Screws: Hex socket head cap screw M3x5 12.9 Lafre 2C2B/FC6.9 (2 pcs)</p> <p>Tightening torque: 1.5 Nm \pm10%</p>  <p>xx1800003409</p>

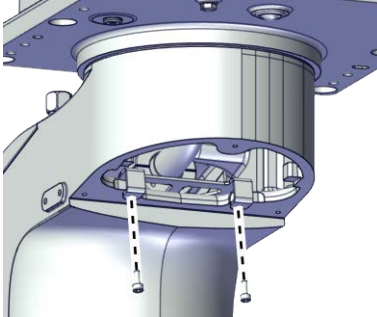
Continues on next page

	Action	Note
3	Refit the bracket into the inner arm and secure with the screws.	<p>Screws: Hex socket head cap screw M3x5 12.9 Lafre 2C2B/FC6.9 (2 pcs)</p> <p>Tightening torque: 1.5 Nm ±10%</p>  <p>xx1800003408</p>

Refitting the cable bracket

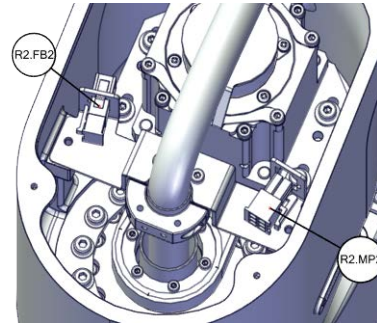

	Action	Note
1	<p>For robots with protection type Clean Room: Clean the joints that have been opened and wipe the parts free from particles with spirit on a lint free. See Cut the paint or surface on the robot before replacing parts on page 118</p> <p> Note</p> <p>After all repair work, wipe the Clean Room robot free from particles with spirit on a lint free cloth.</p>	
2	<p>Reconnect the connectors.</p> <ul style="list-style-type: none"> • R2.MP2 • R2.FB2 <p> Tip</p> <p>Take photos of the connector and cable position before disconnecting them, to have as a reference when reconnecting.</p> <p> Tip</p> <p>See the number markings on the connectors for help to find the corresponding connector.</p>	 <p>xx1800002875</p>
3	Lay the internal harness in a natural state without distortion.	

Continues on next page

5 Repair

5.5.1 Replacing the inner arm



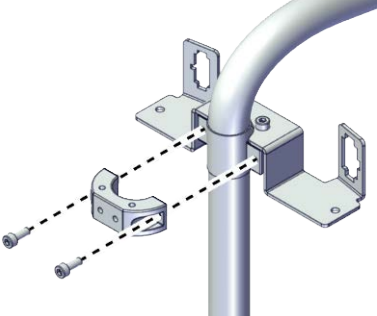
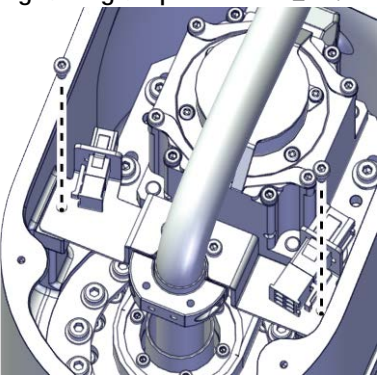

Continued

	Action	Note
4	<p>Refit the cable ferrule on the cable at the marked position and secure with screws.</p> <p> Tip</p> <p>The position with wrapped tape is the marked position for the cable ferrule.</p> <p> Tip</p> <p>Align all the cable ferrules so that the cable is in a natural bending position to avoid twisting.</p>	<p>Screws: Hex socket head cap screw M3x8 12.9 Lafre 2C2B/FC6.9 (2 pcs)</p> <p>Tightening torque: 1.5 Nm \pm10%</p>  <p>xx1800002876</p>
5	<p>Refit the bracket and secure with the screws.</p>	<p>Screws: Hex socket head cap screw M3x5 12.9 Lafre 2C2B/FC6.9 (2 pcs)</p> <p>Tightening torque: 1.5 Nm \pm10%</p>  <p>xx1800002874</p>

Refitting the cable ferrule and protected bracket

	Action	Note
1	<p>For robots with protection type Clean Room: Clean the joints that have been opened and wipe the parts free from particles with spirit on a lint free. See Cut the paint or surface on the robot before replacing parts on page 118</p> <p> Note</p> <p>After all repair work, wipe the Clean Room robot free from particles with spirit on a lint free cloth.</p>	
2	<p>Lay the internal harness in a natural state without distortion.</p>	

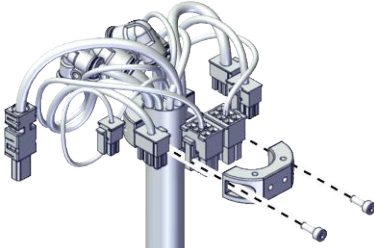

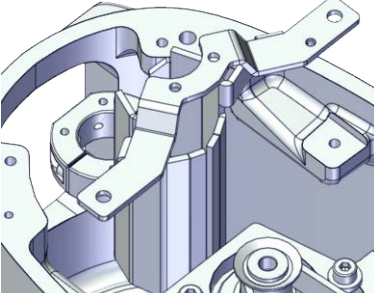
Continues on next page

	Action	Note
3	<p>Refit the cable ferrule and secure it with the screws.</p> <p> Tip</p> <p>The air hoses should face the process hub side.</p> <p> Tip</p> <p>The position with wrapped tape is the marked position for the cable ferrule.</p> <p> Tip</p> <p>Align all the cable ferrules so that the cable is in a natural bending position to avoid twisting.</p>	<p>Screws: Hex socket head cap screw M3x8 12.9 Lafre 2C2B/FC6.9 (2 pcs)</p> <p>Tightening torque: 1.5 Nm \pm10%</p>  <p>xx1800002849</p>
4	<p>Refit the protected bracket.</p> <p> Tip</p> <p>Do not secure it with the screws before the cable ferrule installed well.</p> <p> Note</p> <p>The harness are not visible due to the cleanness requirements of the illustration. They are still existing inside the cable ferrule in the actual situation.</p>	<p>Screws: Hex socket head cap screw M4x8 12.9 Lafre 2C2B/FC6.9 (2 pcs)</p> <p>Tightening torque: 4 Nm \pm10%</p>  <p>xx1900000078</p>

5 Repair

5.5.1 Replacing the inner arm



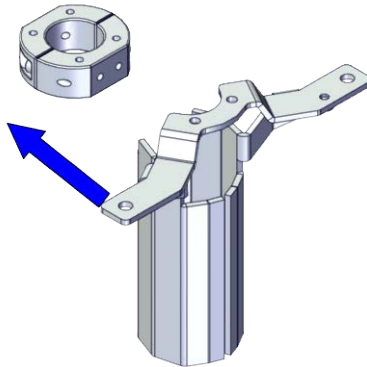
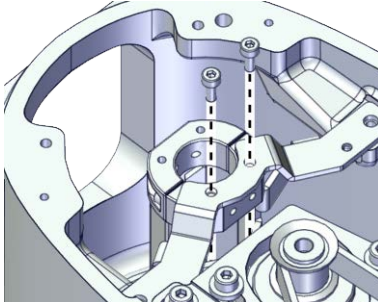

Continued

	Action	Note
5	<p>Secure the cable ferrule to the protected bracket.</p> <p> Tip</p> <p>Align all the cable ferrules so that the cable is in a natural bending position to avoid twisting.</p> <p> Note</p> <p>The harness are not visible due to the cleanliness requirements of the illustration. They are still existing inside the cable ferrule in the actual situation.</p>	<p>Screws: Hex socket head cap screw M3x5 12.9 Lafre 2C2B/FC6.9 (2 pcs)</p> <p>Tightening torque: 1.5 Nm \pm10%</p>  <p>xx190000076</p>  <p>xx190000075</p>

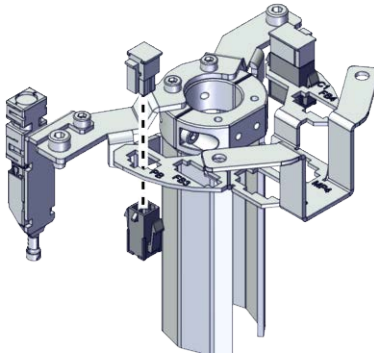

Reconnecting the connector for PB

	Action	Note
1	<p>For robots with protection type Clean Room: Clean the joints that have been opened and wipe the parts free from particles with spirit on a lint free. See Cut the paint or surface on the robot before replacing parts on page 118</p> <p> Note</p> <p>After all repair work, wipe the Clean Room robot free from particles with spirit on a lint free cloth.</p>	

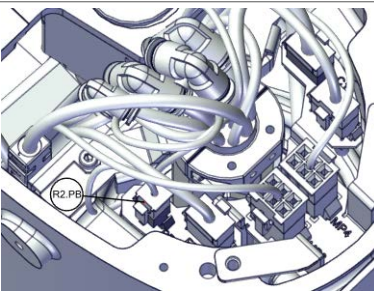
Continues on next page

	Action	Note
2	<p>Insert the female head of the PB connector to the bracket accordingly.</p> <p> Tip</p> <p>The mistake proofing measure has been applied to the connectors, the connectors may be damaged if excessive force is used.</p> <p> Note</p> <p>The harness are not visible due to the cleanness requirements of the illustration. They are still existing inside the cable ferrule in the actual situation.</p>	 <p>xx1900000069</p>
3	<p>Reconnect the connector.</p> <ul style="list-style-type: none"> • R2.PB <p> Tip</p> <p>See the number markings on the connectors for help to find the corresponding connector.</p>	 <p>xx1900000068</p>

Reconnecting the air hoses, CP/CS cabling and Ethernet cabling (if equipped)







	Action	Note
1	<p>For robots with protection type Clean Room: Clean the joints that have been opened and wipe the parts free from particles with spirit on a lint free. See Cut the paint or surface on the robot before replacing parts on page 118</p> <p> Note</p> <p>After all repair work, wipe the Clean Room robot free from particles with spirit on a lint free cloth.</p>	
2	<p>Route the air hoses on the process hub behind the protected bracket.</p> <p> CAUTION</p> <p>Correct cable routing is highly important. If the cables are routed and secured incorrectly the cables can be damaged.</p>	

Continues on next page

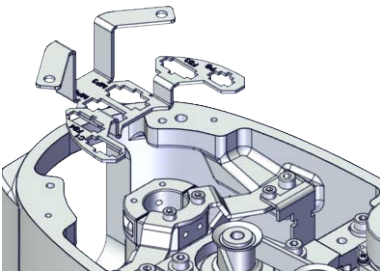

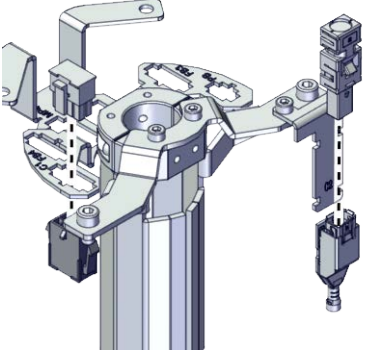

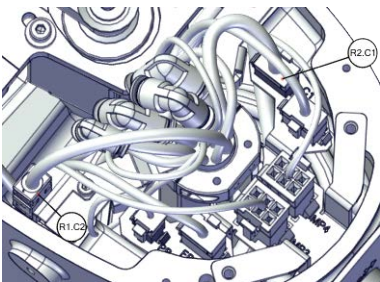
5 Repair

5.5.1 Replacing the inner arm

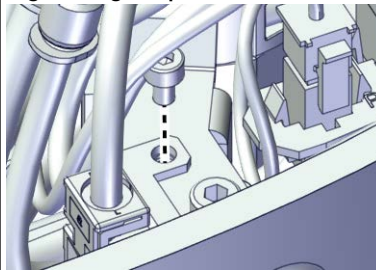

Continued

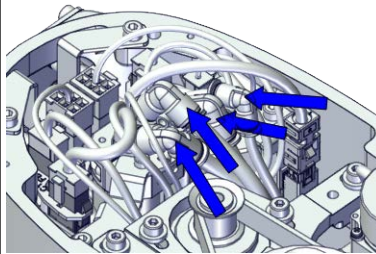
	Action	Note
3	<p>Refit the bracket to the outer arm without screws.</p> <p> Note</p> <p>The harness are not visible due to the cleanness requirements of the illustration. They are still existing inside the cable ferrule in the actual situation.</p>	 <p>xx1900000073</p>
4	<p>Insert the female head of the C1 cabling connector to the bracket accordingly.</p> <p> Tip</p> <p>The mistake proofing measure has been applied to the connectors, the connectors may be damaged if excessive force is used.</p>	 <p>xx1900000071</p>
5	<p>For robots with C1 cabling</p> <p>Reconnect the connector.</p> <ul style="list-style-type: none"> • R2.C1 <p> Tip</p> <p>See the number markings on the air hoses for help to find the corresponding air hoses. The air hoses with the same number connect to the same L-shaped connector.</p> <p> Note</p> <p>The harness are not visible due to the cleanness requirements of the illustration. They are still existing inside the cable ferrule in the actual situation.</p>	 <p>xx1900000070</p>
6	<p>For robots with C2 cabling</p> <p>Reconnect the connector.</p> <ul style="list-style-type: none"> • R1.C2 <p> Tip</p> <p>See the number markings on the air hoses for help to find the corresponding air hoses. The air hoses with the same number connect to the same L-shaped connector.</p>	
7	<p>Secure the C2 cabling to the C2 bracket with the cable straps.</p>	

Continues on next page

	Action	Note
8	Secure the C2 bracket to the bracket with screw.	<p>Screws: Hex socket head cap screw M3x5 12.9 Lafre 2C2B/FC6.9 (1 pcs)</p> <p>Tightening torque: 4 Nm \pm10%</p>  <p>xx1900000098</p>
9	<p>Reconnect the air hoses in a cross pattern with the L-shaped connectors.</p>  Tip <p>See the number markings on the air hoses for help to find the corresponding air hoses. The air hoses with the same number connect to the same Y-shaped connector.</p>	 <p>xx1800002837</p>
10	<p>Route and secure the cabling with cable straps if needed.</p>  CAUTION <p>Correct cable routing is highly important. If the cables are routed and secured incorrectly the cables can be damaged.</p>	

Reconnecting the connectors for axis-3 motor



	Action	Note
1	<p>For robots with protection type Clean Room: Clean the joints that have been opened and wipe the parts free from particles with spirit on a lint free. See Cut the paint or surface on the robot before replacing parts on page 118</p>  Note <p>After all repair work, wipe the Clean Room robot free from particles with spirit on a lint free cloth.</p>	
2	<p>Route the cabling on the axis-3 motor behind the protected bracket to the bracket.</p>  CAUTION <p>Correct cable routing is highly important. If the cables are routed and secured incorrectly the cables can be damaged.</p>	

Continues on next page

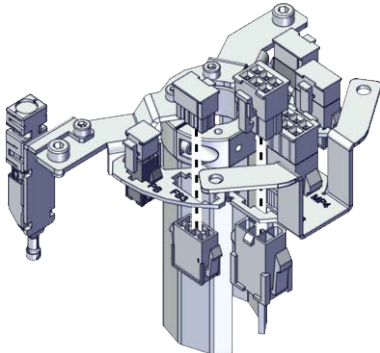

5 Repair

5.5.1 Replacing the inner arm

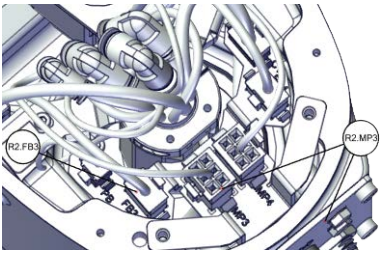
Continued



	Action	Note
3	<p>Insert the female head of the connectors to the bracket accordingly.</p> <p> Tip</p> <p>The mistake proofing measure has been applied to the connectors, the connectors may be damaged if excessive force is used.</p>	 <p>xx1900000064</p>
4	<p>Reconnect the connectors.</p> <ul style="list-style-type: none"> • R2.MP3 • R2.FB3 <p> Tip</p> <p>See the number markings on the connectors for help to find the corresponding connector.</p>	 <p>xx1900000063</p>

Reconnecting the connectors for axis-4 motor

	Action	Note
1	<p>For robots with protection type Clean Room: Clean the joints that have been opened and wipe the parts free from particles with spirit on a lint free. See Cut the paint or surface on the robot before replacing parts on page 118</p> <p> Note</p> <p>After all repair work, wipe the Clean Room robot free from particles with spirit on a lint free cloth.</p>	
2	<p>Route the cabling on the axis-4 motor behind the protected bracket to the bracket.</p> <p> CAUTION</p> <p>Correct cable routing is highly important. If the cables are routed and secured incorrectly the cables can be damaged.</p>	

Continues on next page

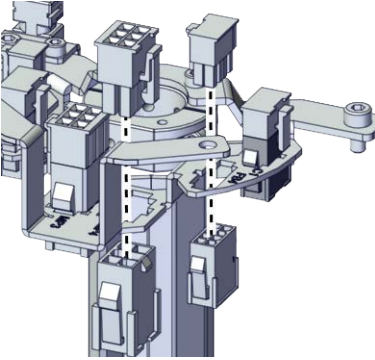
5.5.1 Replacing the inner arm
Continued

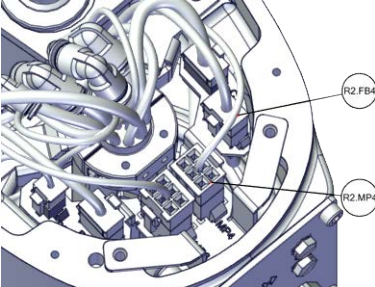
	Action	Note
	<p>Insert the female head of the connectors to the bracket accordingly.</p> <p> Tip</p> <p>The mistake proofing measure has been applied to the connectors, the connectors may be damaged if excessive force is used.</p>	 <p>xx190000066</p>
3	<p>Reconnect the connectors.</p> <ul style="list-style-type: none"> • R2.MP4 • R2.FB4 <p> Tip</p> <p>See the number markings on the connectors for help to find the corresponding connector.</p>	 <p>xx190000065</p>

Refitting the bracket for the process hub

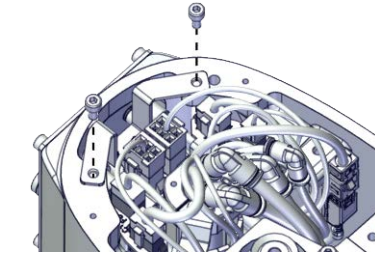
	Action	Note
1	<p>For robots with protection type Clean Room: Clean the joints that have been opened and wipe the parts free from particles with spirit on a lint free. See Cut the paint or surface on the robot before replacing parts on page 118</p> <p> Note</p> <p>After all repair work, wipe the Clean Room robot free from particles with spirit on a lint free cloth.</p>	
2	<p>Secure the bracket with screws.</p>	<p>Screws: Hex socket head cap screw M4x8 12.9 Lafre 2C2B/FC6.9 (2 pcs) Tightening torque: 4 Nm ±10%</p>  <p>xx1800002839</p>



Continues on next page

5 Repair

5.5.1 Replacing the inner arm

Continued

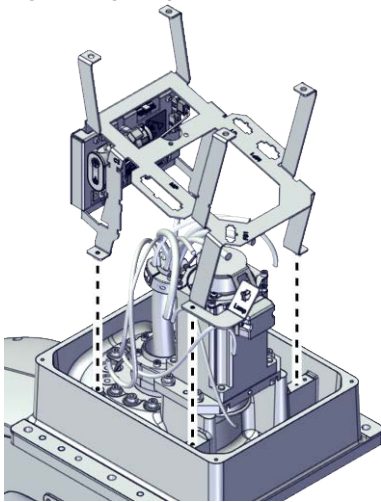
Refitting the bracket

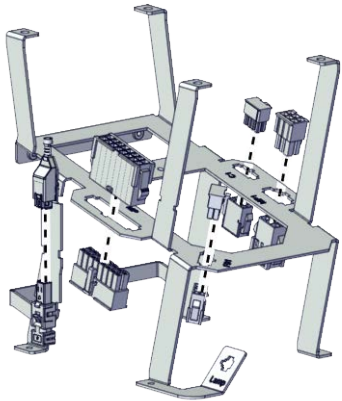
	Action	Note
1	<p>For robots with protection type Clean Room: Clean the joints that have been opened and wipe the parts free from particles with spirit on a lint free. See Cut the paint or surface on the robot before replacing parts on page 118</p> <p> Note</p> <p>After all repair work, wipe the Clean Room robot free from particles with spirit on a lint free cloth.</p>	
2	<p>Refit the bracket and secure with the screws.</p>	<p>Screws: Hex socket head cap screw M3x8 12.9 Lafre 2C2B/FC6.9 (4 pcs) Tightening torque: 1.5 Nm \pm10%</p>  <p>xx1800002869</p>
3	<p>Insert the female head of the connectors to the bracket accordingly.</p> <p> Tip</p> <p>The mistake proofing measure has been applied to the connectors, the connectors may be damaged if excessive force is used.</p>	 <p>xx1900000081</p>

Continues on next page

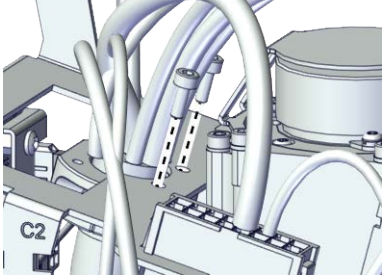
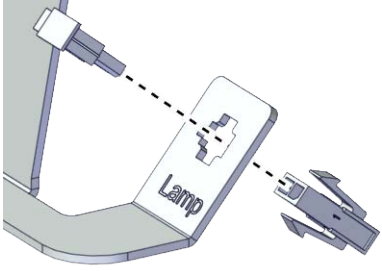
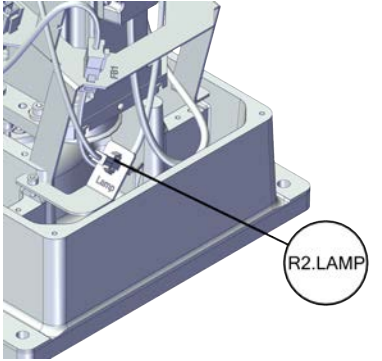
	Action	Note
4	Secure the cable ferrule to the bracket with the screws.	<p>Screws: Hex socket head cap screw M3x5 12.9 Lafre 2C2B/FC6.9 (2 pcs) Tightening torque: 1.5 Nm ±10%</p>  <p>xx190000080</p>
5	Reconnect the lamp connector on the bracket.	 <p>xx190000079</p>  <p>xx1800002867</p>

Refitting the base harness

	Action	Note
1	<p>For robots with protection type Clean Room: Clean the joints that have been opened and wipe the parts free from particles with spirit on a lint free. See Cut the paint or surface on the robot before replacing parts on page 118</p> <p> Note</p> <p>After all repair work, wipe the Clean Room robot free from particles with spirit on a lint free cloth.</p>	



5 Repair

5.5.1 Replacing the inner arm

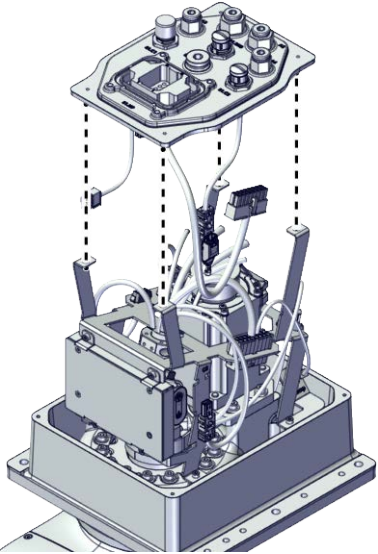
Continued

	Action	Note
2	Refit the base harness to the bracket.	 <p data-bbox="1031 869 1136 887">xx1800002834</p>

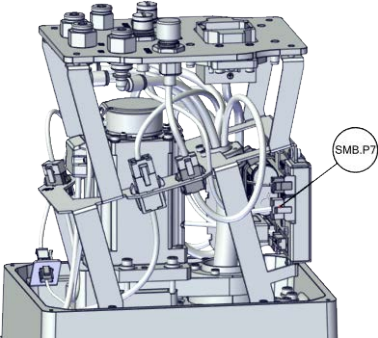

Reconnecting the SMB cabling

	Action	Note
1	 <p data-bbox="571 1070 1002 1102">ELECTROSTATIC DISCHARGE (ESD)</p> <p data-bbox="485 1137 1018 1218">The unit is sensitive to ESD. Before handling the unit read the safety information in section The unit is sensitive to ESD on page 45.</p>	
2	<p data-bbox="485 1254 1018 1397">For robots with protection type Clean Room: Clean the joints that have been opened and wipe the parts free from particles with spirit on a lint free. See Cut the paint or surface on the robot before replacing parts on page 118</p> <p data-bbox="485 1415 542 1469"> Note</p> <p data-bbox="485 1487 1018 1541">After all repair work, wipe the Clean Room robot free from particles with spirit on a lint free cloth.</p>	
3	<p data-bbox="485 1572 778 1603">Reconnect the connectors.</p> <ul data-bbox="517 1603 644 1657" style="list-style-type: none"> <li data-bbox="517 1603 644 1630">• SMB.P7 <li data-bbox="517 1635 644 1657">• SMB.J1 <p data-bbox="485 1680 555 1747"> Tip</p> <p data-bbox="485 1765 1018 1818">See the number markings on the connectors for help to find the corresponding connector.</p>	 <p data-bbox="1031 1917 1136 1935">xx1800002833</p>

Continues on next page

	Action	Note
4	<p>Route and secure the cabling with cable straps if needed.</p> <p> CAUTION</p> <p>Correct cable routing is highly important. If the cables are routed and secured incorrectly the cables can be damaged.</p>	

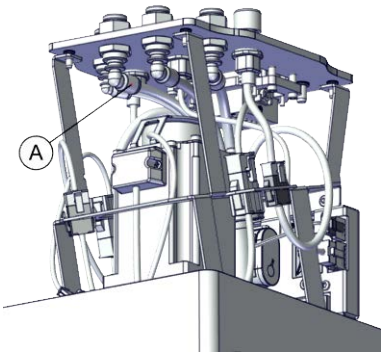

Reconnecting the air hoses, C1 cabling and C2 cabling (if equipped)

	Action	Note		
1	<p>For robots with protection type Clean Room: Clean the joints that have been opened and wipe the parts free from particles with spirit on a lint free. See Cut the paint or surface on the robot before replacing parts on page 118</p> <p> Note</p> <p>After all repair work, wipe the Clean Room robot free from particles with spirit on a lint free cloth.</p>			
2	<p>Reconnect the air hoses in a cross pattern to the L-shaped connectors on the base harness.</p> <p> Tip</p> <p>See the number markings on the air hoses for help to find the corresponding air hoses. The air hoses with the same number connect to the same L-shaped connector.</p> <p> Note</p> <p>Make sure that the air hoses are not bent or broken when you disconnect them.</p>	 <p>xx1800002830</p> <table border="1"> <tr> <td>A</td> <td>Air hoses</td> </tr> </table>	A	Air hoses
A	Air hoses			

5 Repair

5.5.1 Replacing the inner arm

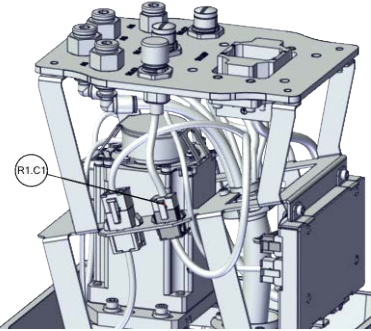
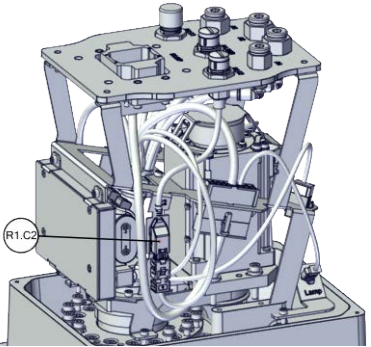

Continued

	Action	Note
3	<p>Reconnect the connectors.</p> <ul style="list-style-type: none"> • R1.C1 • R1.C2 <p> Tip</p> <p>See the number markings on the connectors for help to find the corresponding connector.</p>	 <p>xx1800002831</p>  <p>xx1800002832</p>
4	<p>Route and secure the cabling with cable straps if needed.</p> <p> CAUTION</p> <p>Correct cable routing is highly important. If the cables are routed and secured incorrectly the cables can be damaged.</p>	

Reconnecting the connectors on the base harness

	Action	Note
1	<p>For robots with protection type Clean Room: Clean the joints that have been opened and wipe the parts free from particles with spirit on a lint free. See Cut the paint or surface on the robot before replacing parts on page 118</p> <p> Note</p> <p>After all repair work, wipe the Clean Room robot free from particles with spirit on a lint free cloth.</p>	

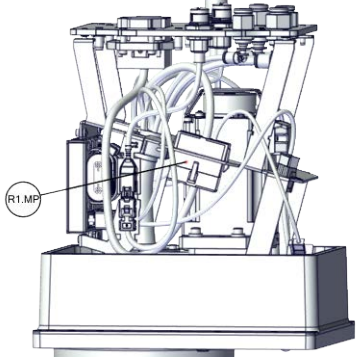
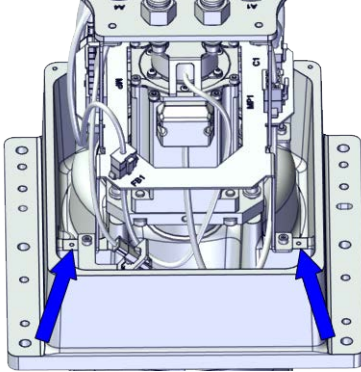
Continues on next page

	Action	Note
2	<p>Reconnect the connector.</p> <ul style="list-style-type: none"> R1.MP <p> Tip</p> <p>See the number markings on the connectors for help to find the corresponding connector.</p>	 <p>xx1800002829</p>
3	<p>Secure the three grounding cables to the bracket with the screw.</p>	<p>Screws: Hex socket head cap screw M3x5 12.9 Lafre 2C2B/FC6.9 (2 pcs)</p> <p>Tightening torque: 1.5 Nm ±10%</p>  <p>xx1900000062</p>
4	<p>Route and secure the cabling with cable straps if needed.</p> <p> CAUTION</p> <p>Correct cable routing is highly important. If the cables are routed and secured incorrectly the cables can be damaged.</p>	

Refitting the base cover



	Action	Note
1	<p>For robots with protection type Clean Room:</p> <p>Clean the joints that have been opened and wipe the parts free from particles with spirit on a lint free. See Cut the paint or surface on the robot before replacing parts on page 118</p> <p> Note</p> <p>After all repair work, wipe the Clean Room robot free from particles with spirit on a lint free cloth.</p>	

Continues on next page

5 Repair

5.5.1 Replacing the inner arm

Continued

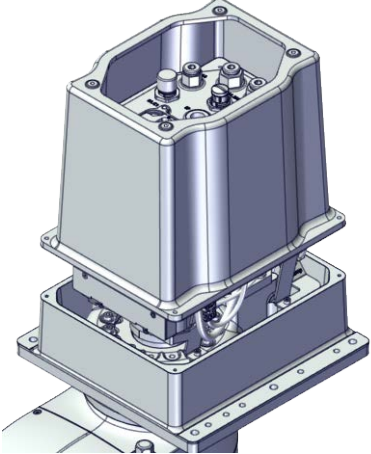
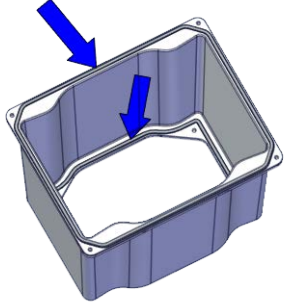
	Action	Note
2	Apply grease to the internal harness, cover all moving area of the harness.	
3	Apply grease to the covers that have contacting area with the harness.	
4	<p>Refit the base cover.</p> <p> Note</p> <p>For robots with protection class IP54 (option 3350-540)</p> <p>For robots with protection type Clean Room (option 3351-1)</p> <p>Check the gasket for the base and the gasket for the base cover before refitting the base cover.</p> <p> Tip</p> <p>Replace the gasket if needed.</p>	 <p>xx1800002828</p> <p>For robots with protection class IP54 (option 3350-540)</p> <p>For robots with protection type Clean Room (option 3351-1)</p>  <p>xx1900001635</p>

Continues on next page

5.5.1 Replacing the inner arm

Continued

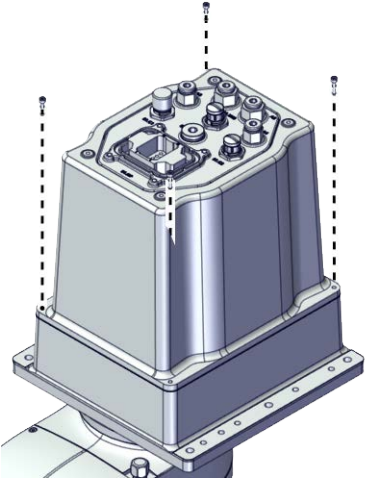
	Action	Note
5	Secure the base cover to the base with the screws.	<p>Screws: Hex socket head cap screw M3x12 12.9 Lafre 2C2B/FC6.9 (4 pcs)</p> <p>Tightening torque: 1.2 Nm \pm10%</p>  <p>xx1800002827</p>

Continues on next page

5 Repair

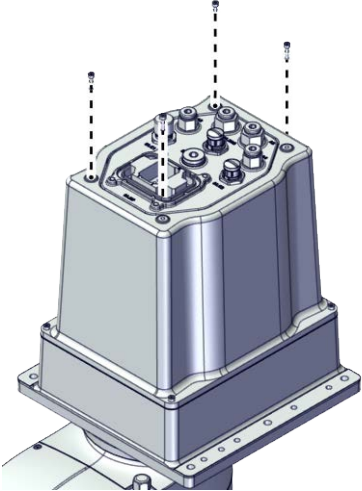
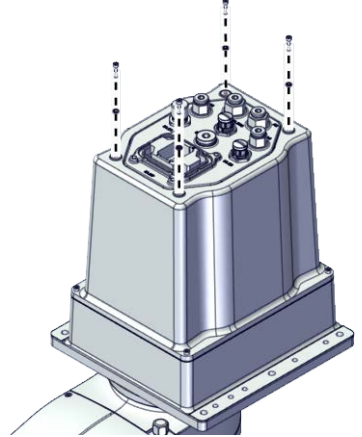

5.5.1 Replacing the inner arm

Continued

	Action	Note
6	<p>Secure the base harness to the base cover with the screws.</p> <p> Note</p> <p>For robots with protection class IP54 (option 3350-540)</p> <p>For robots with protection type Clean Room (option 3351-1)</p> <p>Refit the extra sealing washers on the base cover to the base harness.</p>	<p>For robots with protection class IP30 (option 3350-300)</p> <p>Screws: Hex socket head cap screw M3x12 12.9 Lafre 2C2B/FC6.9 (4 pcs)</p> <p>Tightening torque: 1.2 Nm \pm10%</p>  <p>xx1800002826</p> <p>For robots with protection class IP54 (option 3350-540)</p> <p>For robots with protection type Clean Room (option 3351-1)</p> <p>Screws: Hex socket head cap screw M3x12 12.9 Lafre 2C2B/FC6.9 (4 pcs)</p> <p>Washers: Sealing washer M3 (4 pcs)</p> <p>Tightening torque: 1.2 Nm \pm10%</p>  <p>xx1900001634</p>

Continues on next page

Refitting the casting cover of the inner arm

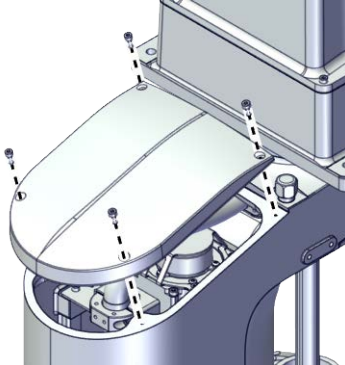
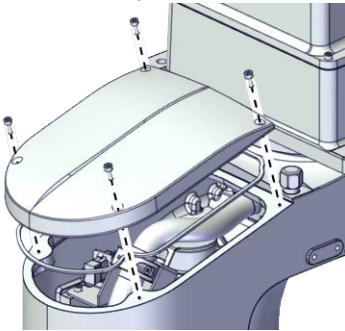
	Action	Note
1	<p>For robots with protection type Clean Room: Clean the joints that have been opened and wipe the parts free from particles with spirit on a lint free. See Cut the paint or surface on the robot before replacing parts on page 118</p> <p> Note</p> <p>After all repair work, wipe the Clean Room robot free from particles with spirit on a lint free cloth.</p>	
2	<p>Refit the casting cover.</p> <p> Note</p> <p>For robots with protection class IP54 (option 3350-540)</p> <p>For robots with protection type Clean Room (option 3351-1)</p> <p>Check the gasket for the casting cover before refitting the base cover.</p> <p> Tip</p> <p>Replace the gasket if needed.</p>	<p>Screw: Hex socket head cap screw M3x8 12.9 Lafre 2C2B/FC6.9 (4 pcs)</p> <p>Tightening torque: 1.2 Nm ±10%</p> <p>For robots with protection class IP30 (option 3350-300)</p>  <p>xx1800002873</p>
3	<p>Refit the screws.</p>	<p>For robots with protection class IP54 (option 3350-540)</p> <p>For robots with protection type Clean Room (option 3351-1)</p>  <p>xx1900001637</p>



Continues on next page

5 Repair

5.5.1 Replacing the inner arm

Continued

Refitting the cover of the inner arm

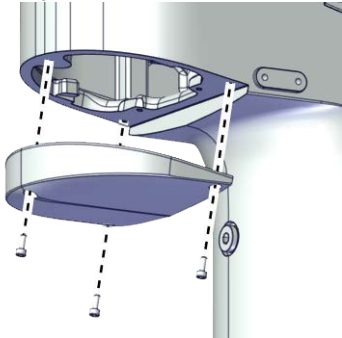
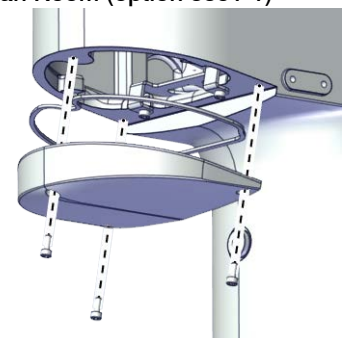
	Action	Note
1	<p>For robots with protection type Clean Room: Clean the joints that have been opened and wipe the parts free from particles with spirit on a lint free. See Cut the paint or surface on the robot before replacing parts on page 118</p> <p> Note</p> <p>After all repair work, wipe the Clean Room robot free from particles with spirit on a lint free cloth.</p>	
2	<p>Refit the cover.</p> <p> Note</p> <p>For robots with protection class IP54 (option 3350-540)</p> <p>For robots with protection type Clean Room (option 3351-1)</p> <p>Check the gasket for the cover before refitting the base cover.</p> <p> Tip</p> <p>Replace the gasket if needed.</p>	<p>Screw: Hex socket head cap screw M3x8 12.9 Lafre 2C2B/FC6.9 (3 pcs)</p> <p>Tightening torque: 1.2 Nm \pm10%</p> <p>For robots with protection class IP30 (option 3350-300)</p>  <p>xx1800002899</p>
3	<p>Refit the screws.</p>	<p>For robots with protection class IP54 (option 3350-540)</p> <p>For robots with protection type Clean Room (option 3351-1)</p>  <p>xx1900001636</p>

Continues on next page

Refitting the cover of the outer arm



	Action	Note
1	<p>For robots with protection type Clean Room: Clean the joints that have been opened and wipe the parts free from particles with spirit on a lint free. See Cut the paint or surface on the robot before replacing parts on page 118</p> <p> Note</p> <p>After all repair work, wipe the Clean Room robot free from particles with spirit on a lint free cloth.</p>	

Continues on next page

5 Repair

5.5.1 Replacing the inner arm

Continued

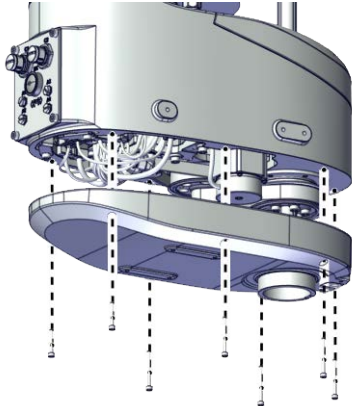
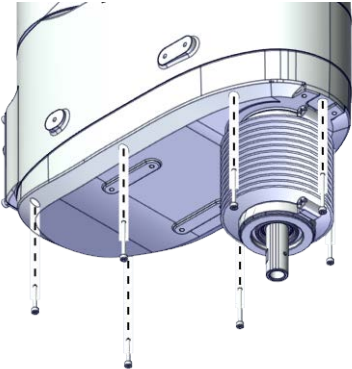
	Action	Note
2	<p>Refit the cover.</p> <p> Note</p> <p>For robots with protection class IP54 (option 3350-540)</p> <p>For robots with protection type Clean Room (option 3351-1)</p> <p>Refit the cover with bellow and housing.</p> <p>Check the gasket on the outer arm cover.</p> <p> Tip</p> <p>Replace the gasket if needed.</p>	<p>For IRB 910INV-3/0.35:</p> <p>Screw: Hex socket head cap screw M3x20 12.9 Lafre 2C2B/FC6.9 (2 pcs)</p> <p>Hex socket head cap screw M3x30 12.9 Lafre 2C2B/FC6.9 (5 pcs)</p> <p>Tightening torque: 1.2 Nm ±10%</p> <p>For IRB 910INV-6/0.55:</p> <p>Screw: Hex socket head cap screw M3x20 12.9 Lafre 2C2B/FC6.9 (2 pcs)</p> <p>Hex socket head cap screw M3x30 12.9 Lafre 2C2B/FC6.9 (7 pcs)</p> <p>Tightening torque: 1.2 Nm ±10%</p> <p>For robots with protection class IP30 (option 3350-300)</p>
3	<p>Refit the screws.</p>	 <p>xx1800002836</p> <p>For robots with protection class IP54 (option 3350-540)</p> <p>For robots with protection type Clean Room (option 3351-1)</p>  <p>xx1900001631</p>

Continues on next page

Refitting the lower cover

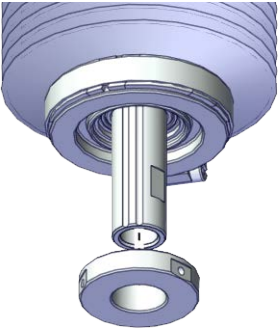
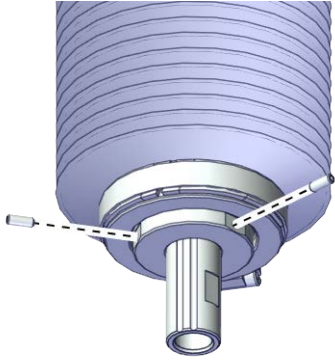
	Action	Note
1	<p>For robots with protection type Clean Room: Clean the joints that have been opened and wipe the parts free from particles with spirit on a lint free. See Cut the paint or surface on the robot before replacing parts on page 118</p> <p> Note</p> <p>After all repair work, wipe the Clean Room robot free from particles with spirit on a lint free cloth.</p>	
2	<p>For robots with protection class IP54 (option 3350-540) For robots with protection type Clean Room (option 3351-1) Refit the lower cover to the ball screw.</p>	 <p>xx1900001607</p>
3	<p>For robots with protection class IP54 (option 3350-540) For robots with protection type Clean Room (option 3351-1) Refit the locking screws.</p>	<p>Screws: Hexagon socket set screws with flat point, ISO 4026 stainless steel M3x8 (2 pcs) Tightening torque: 0.6 Nm ±10%</p>  <p>xx1900001606</p>



Continues on next page

5 Repair

5.5.1 Replacing the inner arm

Continued

Concluding procedure

	Action	Note
1	<p>For robots with protection type Clean Room: Seal and paint the joints that have been opened. See Cut the paint or surface on the robot before replacing parts on page 118</p> <p> Note</p> <p>After all repair work, wipe the Clean Room robot free from particles with spirit on a lint free cloth.</p>	
2	Recalibrate the robot.	Calibration is detailed in section Calibration on page 771 .
3	<p> DANGER</p> <p>Make sure all safety requirements are met when performing the first test run. See Test run after installation, maintenance, or repair on page 56.</p>	

5.5.2 Replacing the axis-2 timing belt

Location of the axis-2 timing belt

The axis-2 timing belt is located as shown in the figure.

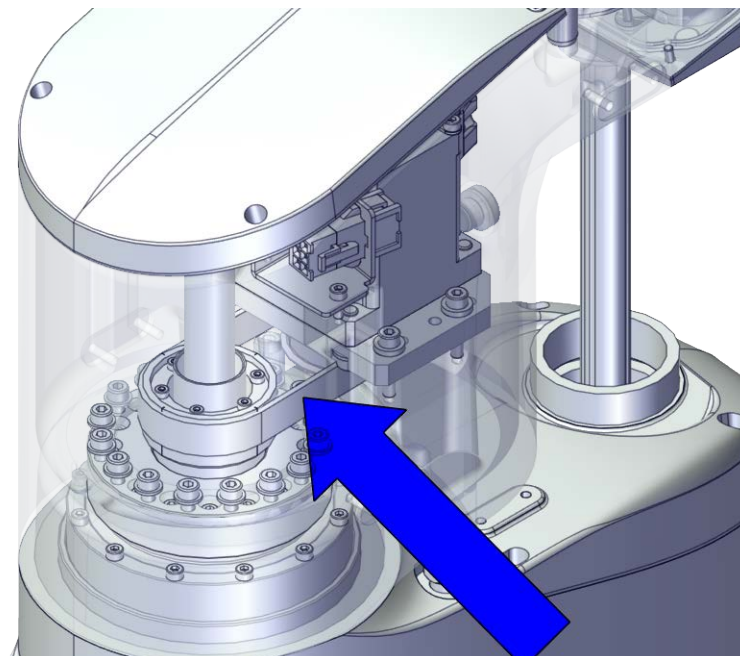

xx1800002856

Required spare parts



Note

The spare part numbers that are listed in the table can be out of date. See the latest spare parts of the IRB 910INV via myABB Business Portal, www.abb.com/myABB.

Spare part	Article number	Note
Timing belt	3HAC061861-001	

Required tools and equipment

Equipment	Article number	Note
Standard toolkit	-	Content is defined in section Standard toolkit on page 840 .
Calibration tool box, Axis Calibration	3HAC074119-001	Delivered as a set of calibration tools. Required if Axis Calibration is the valid calibration method for the robot. ¹
Sonic tension meter	-	Used for measuring the timing belt tension.

Continues on next page

5 Repair

5.5.2 Replacing the axis-2 timing belt

Continued

Equipment	Article number	Note
Handheld dynamometer	-	Used for measuring the timing belt tension.

- i The robot is calibrated by either manual calibration or Axis Calibration at ABB factory before delivery. Always use the same calibration method as used at the factory. Information about valid calibration method is found on the calibration label or in the calibration menu on the FlexPendant. If no data is found related to standard calibration, manual calibration is used as default.

Required consumables

Consumable	Article number	Note
Cable straps	-	
Grease	3HAC029132-001	FM 222 Used to lubricate the cable harness.

Deciding calibration routine

Decide which calibration routine to be used, based on the information in the table. Depending on which routine is chosen, action might be required prior to beginning the repair work of the robot, see the table.

	Action	Note
1	Decide which calibration routine to use for calibrating the robot. <ul style="list-style-type: none">Reference calibration. External cable packages (DressPack) and tools can stay fitted on the robot.Fine calibration. All external cable packages (DressPack) and tools must be removed from the robot.	
	If the robot is to be calibrated with reference calibration: Find previous reference values for the axis or create new reference values. These values are to be used after the repair procedure is completed, for calibration of the robot. If no previous reference values exist, and no new reference values can be created, then reference calibration is not possible.	Follow the instructions given in the reference calibration routine on the FlexPendant to create reference values. Creating new values requires possibility to move the robot. Read more about reference calibration for Axis Calibration in Reference calibration routine on page 798 .
	If the robot is to be calibrated with fine calibration: Remove all external cable packages (DressPack) and tools from the robot.	



Removing the axis-2 timing belt

Use these procedures to remove the axis-2 timing belt.

Preparations before removing the axis-2 timing belt

	Action	Note
1	Decide which calibration routine to use, and take actions accordingly prior to beginning the repair procedure.	

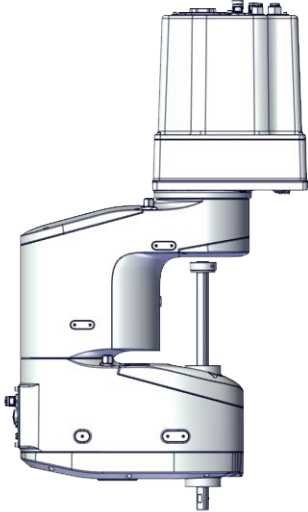
Continues on next page

	Action	Note
2	<p>If there is no enough space for the maintenance work, remove the robot from the wall and place it on the maintenance bracket.</p> <p> CAUTION</p> <p>Do not lay down the robot during the transportation, always keep it straight. If the robot lay down in any situation, the grease may come out from gearbox.</p>	
3	<p>Jog all axes to zero position.</p>	 <p>xx1800002825</p>
4	<p> DANGER</p> <p>Turn off all:</p> <ul style="list-style-type: none"> • electric power supply • hydraulic pressure supply • air pressure supply <p>to the robot, before entering the safeguarded space.</p>	
5	<p> CAUTION</p> <p>For robots with protection type Clean Room Always cut the paint with a knife and grind the paint edge when disassembling parts of the robot! See <i>Cut the paint or surface on the robot before replacing parts on page 118.</i></p>	



Continues on next page

5 Repair

5.5.2 Replacing the axis-2 timing belt

Continued



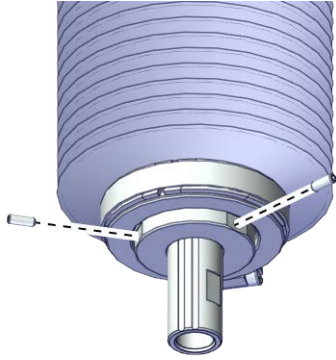
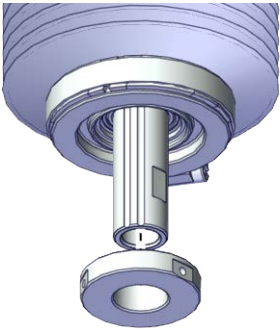

Removing the lower cover

	Action	Note
1	 DANGER Make sure that all supplies for electrical power, hydraulic pressure, and air pressure are turned off.	
2	 CAUTION For robots with protection type Clean Room Always cut the paint with a knife and grind the paint edge when disassembling parts of the robot! See Cut the paint or surface on the robot before replacing parts on page 118 .	
3	For robots with protection class IP54 (option 3350-540) For robots with protection type Clean Room (option 3351-1) Loose the locking screws.	 <small>xx1900001606</small>
4	For robots with protection class IP54 (option 3350-540) For robots with protection type Clean Room (option 3351-1) Remove the lower cover from the ball screw.	 <small>xx1900001607</small>

Removing the cover of the outer arm

	Action	Note
1	 DANGER Make sure that all supplies for electrical power, hydraulic pressure, and air pressure are turned off.	

Continues on next page

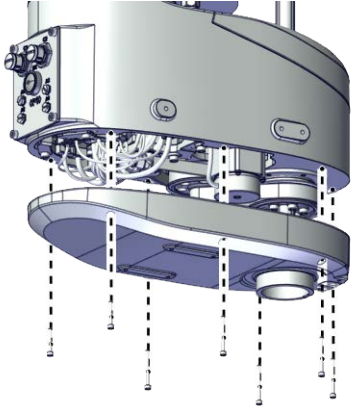
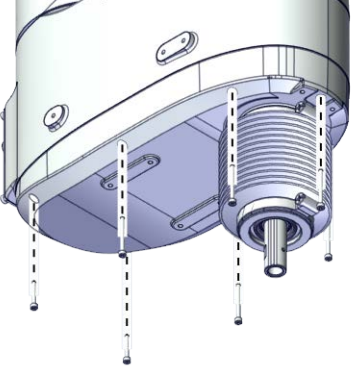
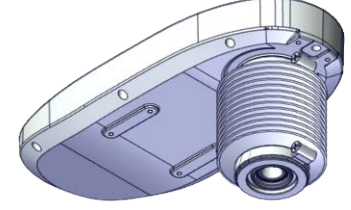
	Action	Note
2	<p> CAUTION</p> <p>For robots with protection type Clean Room Always cut the paint with a knife and grind the paint edge when disassembling parts of the robot! See <i>Cut the paint or surface on the robot before replacing parts on page 118.</i></p>	
3	<p>Remove the screws on the cover of the outer arm and remove the cover.</p> <p> Note</p> <p>For robots with protection class IP54 (option 3350-540) For robots with protection type Clean Room (option 3351-1) Remove the cover with bellow and housing.</p> <p> Note</p> <p>The bellow does not need to be removed separately.</p> <p> CAUTION</p> <p>There is a gasket in the cover. Be careful when removing the cover with bellow and housing.</p> <p> Tip</p> <p>Check the gasket and replace it if needed.</p>	<p>For robots with protection class IP30 (option 3350-300)</p>  <p>xx1800002836</p> <p>For robots with protection class IP54 (option 3350-540) For robots with protection type Clean Room (option 3351-1)</p>  <p>xx1900001631</p>  <p>xx1900001632</p>



Continues on next page

5 Repair



5.5.2 Replacing the axis-2 timing belt

Continued

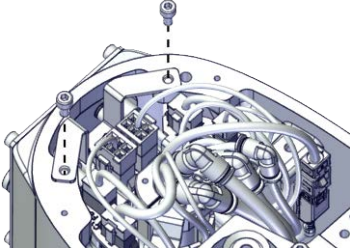
Removing the bracket for the process hub

	Action	Note
1	 DANGER Make sure that all supplies for electrical power, hydraulic pressure, and air pressure are turned off.	
2	 CAUTION For robots with protection type Clean Room Always cut the paint with a knife and grind the paint edge when disassembling parts of the robot! See Cut the paint or surface on the robot before replacing parts on page 118 .	
3	Remove the screws on the bracket and take it out carefully.	 xx1800002839

Disconnecting the connectors for axis-3 motor

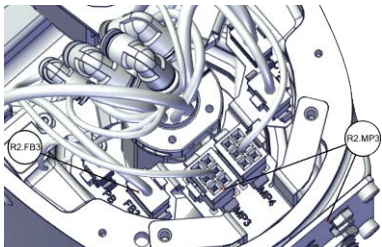

	Action	Note
1	 DANGER Make sure that all supplies for electrical power, hydraulic pressure, and air pressure are turned off.	
2	 CAUTION For robots with protection type Clean Room Always cut the paint with a knife and grind the paint edge when disassembling parts of the robot! See Cut the paint or surface on the robot before replacing parts on page 118 .	
3	Disconnect the connectors. <ul style="list-style-type: none"> • R2.MP3 • R2.FB3 	 xx1900000063

Continues on next page

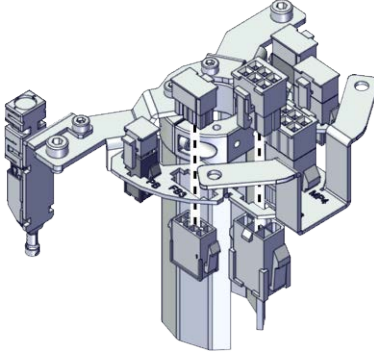
5.5.2 Replacing the axis-2 timing belt
Continued

	Action	Note
4	Snap loose and remove the female head of the connectors from the bracket.	 <p>xx1900000064</p>

Disconnecting the connectors for axis-4 motor

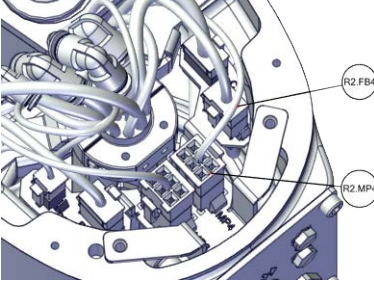
	Action	Note
1	 DANGER Make sure that all supplies for electrical power, hydraulic pressure, and air pressure are turned off.	
2	 CAUTION For robots with protection type Clean Room Always cut the paint with a knife and grind the paint edge when disassembling parts of the robot! See Cut the paint or surface on the robot before replacing parts on page 118.	
3	Disconnect the connectors. <ul style="list-style-type: none"> • R2.MP4 • R2.FB4 	 <p>xx1900000065</p>

Continues on next page



5 Repair

5.5.2 Replacing the axis-2 timing belt

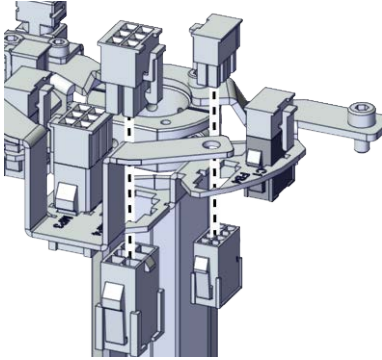
Continued

	Action	Note
4	Snap loose and remove the female head of the connectors from the bracket.	 <p>xx1900000066</p>

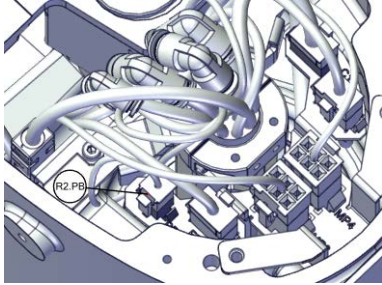

Disconnecting the connector for PB

	Action	Note
1	 DANGER Make sure that all supplies for electrical power, hydraulic pressure, and air pressure are turned off.	
2	 CAUTION For robots with protection type Clean Room Always cut the paint with a knife and grind the paint edge when disassembling parts of the robot! See Cut the paint or surface on the robot before replacing parts on page 118 .	
3	Disconnect the connector. <ul style="list-style-type: none"> R2.PB 	 <p>xx1900000068</p>

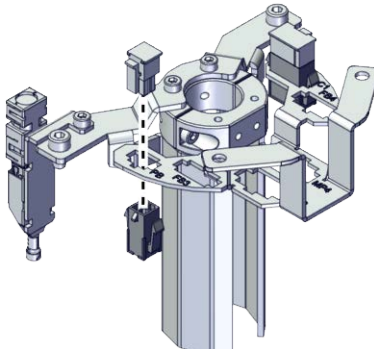
Continues on next page

	Action	Note
4	Snap loose and remove the female head of the connector from the bracket.	 <p>xx190000069</p>

Disconnecting the air hoses, C1 cabling and C2 cabling (if equipped)

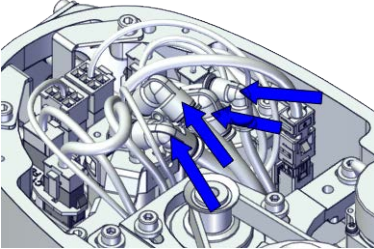



	Action	Note
1	 DANGER Make sure that all supplies for electrical power, hydraulic pressure, and air pressure are turned off.	
2	 CAUTION For robots with protection type Clean Room Always cut the paint with a knife and grind the paint edge when disassembling parts of the robot! See Cut the paint or surface on the robot before replacing parts on page 118 .	
3	Disconnect the air hoses from the L-shaped connectors.	 <p>xx1800002837</p>

Continues on next page

5 Repair

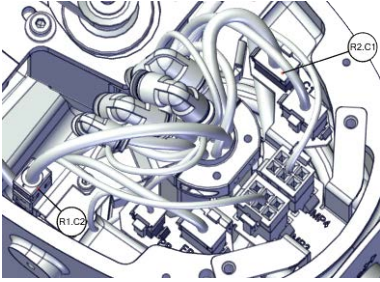

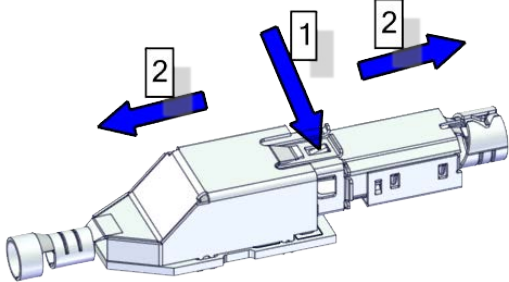
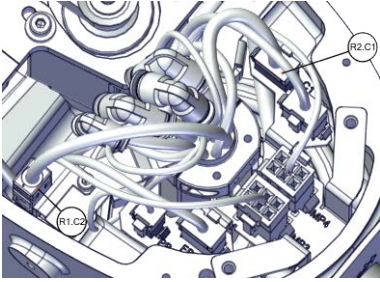
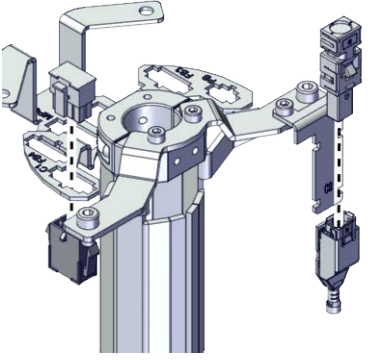

5.5.2 Replacing the axis-2 timing belt

Continued

	Action	Note
4	For robots with C1 cabling Disconnect the connector. <ul style="list-style-type: none">• R2.C1	 xx1900000070
5	For robots with C2 cabling Disconnect the connector. <ul style="list-style-type: none">• R1.C2 <p> Tip</p> <p>Cut the cable straps for the R1.C2 at the same time.</p> <p> Tip</p> <p>Take photos of the connector and cable position before disconnecting them, to have as a reference when reconnecting.</p> <p> Tip</p> <p>The connector clip has to be pressed (1) and pushed forward (2) to separate the R1.C2 (for C2 cabling).</p>  xx1800002943	 xx1900000070
6	Snap loose and remove the female head of the connectors from the bracket.	 xx1900000071

Continues on next page

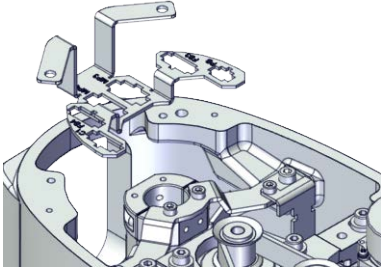
Removing the cable ferrule, bracket and protected bracket

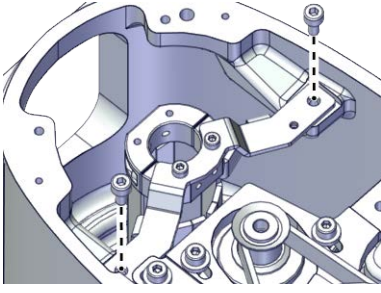

	Action	Note
1	 <p>DANGER</p> <p>Make sure that all supplies for electrical power, hydraulic pressure, and air pressure are turned off.</p>	
2	 <p>CAUTION</p> <p>For robots with protection type Clean Room Always cut the paint with a knife and grind the paint edge when disassembling parts of the robot! See <i>Cut the paint or surface on the robot before replacing parts on page 118.</i></p>	
3	<p>Take out the bracket from the outer arm.</p>  <p>Note</p> <p>The harness are not visible due to the cleanness requirements of the illustration. They are still existing inside the cable ferrule in the actual situation.</p>	 <p>xx1900000073</p>
4	<p>Remove the screws on the protected bracket.</p>  <p>Note</p> <p>The harness are not visible due to the cleanness requirements of the illustration. They are still existing inside the cable ferrule in the actual situation.</p>	 <p>xx1900000074</p>

Continues on next page

5 Repair

5.5.2 Replacing the axis-2 timing belt

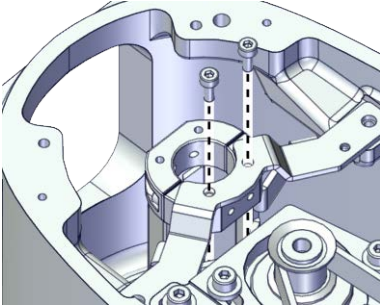
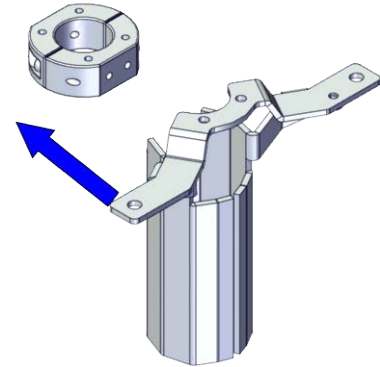

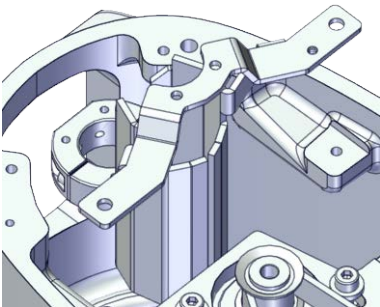
Continued

	Action	Note
5	<p>Remove the screws on the protected bracket to the cable ferrule to release the cable ferrule with cable.</p> <p> Note</p> <p>The harness are not visible due to the cleanness requirements of the illustration. They are still existing inside the cable ferrule in the actual situation.</p>	 <p>xx1900000075</p>  <p>xx1900000076</p>
6	<p>Remove the protected bracket.</p> <p> Tip</p> <p>Pull the protected bracket to the ball screw side to push the cable with the cable ferrule out from the protected bracket.</p> <p> Note</p> <p>The harness are not visible due to the cleanness requirements of the illustration. They are still existing inside the cable ferrule in the actual situation.</p>	 <p>xx1900000078</p>

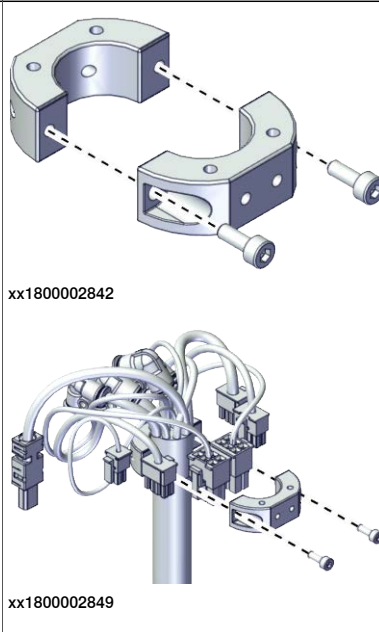
Continues on next page

	Action	Note
7	Remove the screws on the cable ferrule and take the cable ferrule out.	 <p>xx1800002842</p> <p>xx1800002849</p>

Removing the casting cover of the inner arm

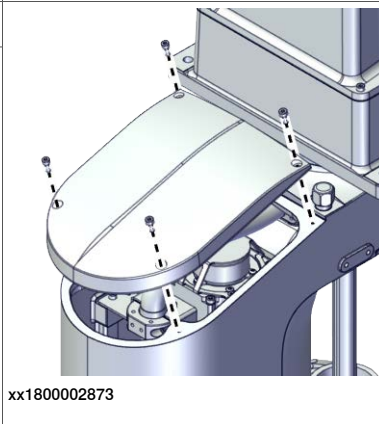
	Action	Note
1	 <p>DANGER</p> <p>Make sure that all supplies for electrical power, hydraulic pressure, and air pressure are turned off.</p>	
2	 <p>CAUTION</p> <p>For robots with protection type Clean Room Always cut the paint with a knife and grind the paint edge when disassembling parts of the robot! See Cut the paint or surface on the robot before replacing parts on page 118.</p>	
3	Remove the screws.	 <p>xx1800002873</p>
4	Remove the casting cover.	





Continues on next page

5 Repair

5.5.2 Replacing the axis-2 timing belt



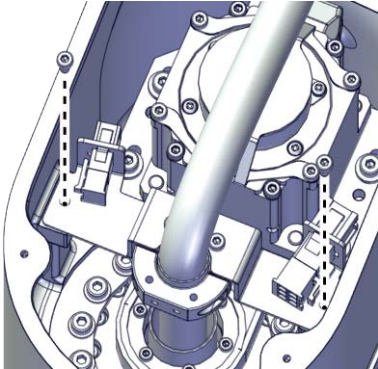
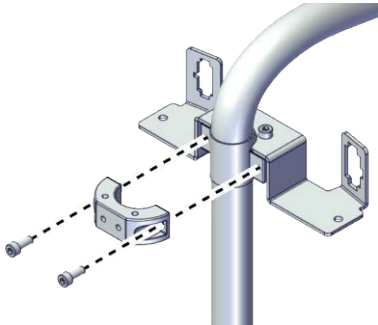

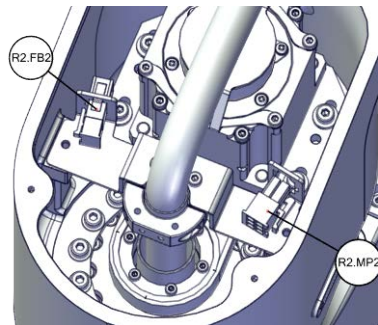
Continued

Removing the cable bracket at the axis -2 motor position in the inner arm

	Action	Note
1	 DANGER Make sure that all supplies for electrical power, hydraulic pressure, and air pressure are turned off.	
2	 CAUTION For robots with protection type Clean Room Always cut the paint with a knife and grind the paint edge when disassembling parts of the robot! See Cut the paint or surface on the robot before replacing parts on page 118 .	
3	Remove the screws.	 xx1800002874
4	Remove the screws on the cable ferrule to release the cable.	 xx1800002876
5	Disconnect the connectors. <ul style="list-style-type: none"> • R2.MP2 • R2.FB2  Tip Take photos of the connector and cable position before disconnecting them, to have as a reference when reconnecting.	 xx1800002875

Continues on next page

Removing the internal harness from the axis -2 gearbox position

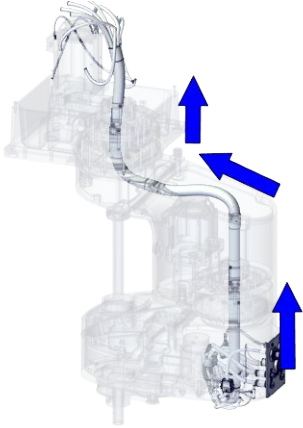
	Action	Note
1	 DANGER Make sure that all supplies for electrical power, hydraulic pressure, and air pressure are turned off.	
2	 CAUTION For robots with protection type Clean Room Always cut the paint with a knife and grind the paint edge when disassembling parts of the robot! See Cut the paint or surface on the robot before replacing parts on page 118 .	
3	Cut the cable straps for R2.MP3 and R2.MP4.  Tip Take photos of the cable straps position before cutting them, to have as a reference when routing the cable.	
4	Pull the internal harness out of the outer arm from the centre of the axis-2 gearbox.  Tip Wrap the connectors with the masking tape.  Tip Take photos of the connector and cable position before disconnecting them, to have as a reference when reconnecting.	 xx1800003411

Removing the axis-2 motor sub-assembly



	Action	Note
1	 DANGER Make sure that all supplies for electrical power, hydraulic pressure, and air pressure are turned off.	

Continues on next page

5 Repair

5.5.2 Replacing the axis-2 timing belt

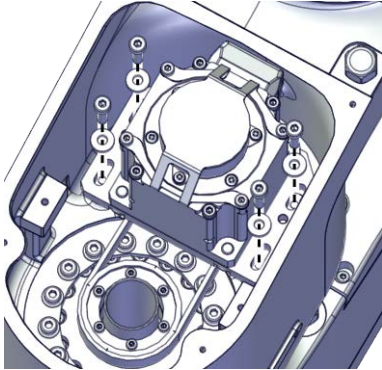
Continued

	Action	Note
2	 CAUTION For robots with protection type Clean Room Always cut the paint with a knife and grind the paint edge when disassembling parts of the robot! See Cut the paint or surface on the robot before replacing parts on page 118 .	
3	Remove the screws and washers.	 xx1800002877
4	Remove the motor and the timing belt.  Tip Move the internal harness out of the way.	



Refitting the axis-2 timing belt

Use these procedures to refit the axis-2 timing belt.

Refitting the axis-2 motor sub-assembly

	Action	Note
1	For robots with protection type Clean Room: Clean the joints that have been opened and wipe the parts free from particles with spirit on a lint free. See Cut the paint or surface on the robot before replacing parts on page 118  Note After all repair work, wipe the Clean Room robot free from particles with spirit on a lint free cloth.	

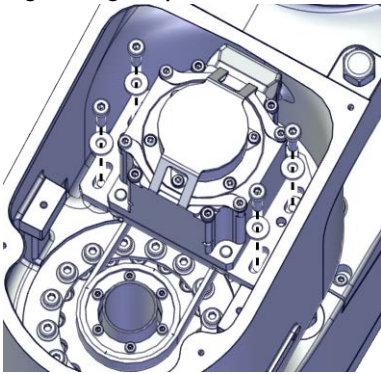
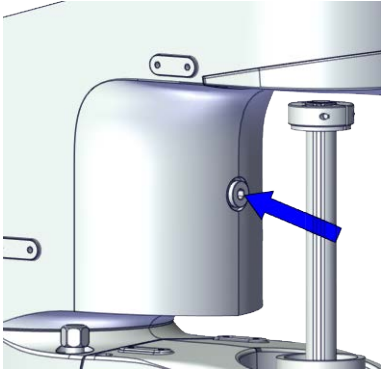
Continues on next page

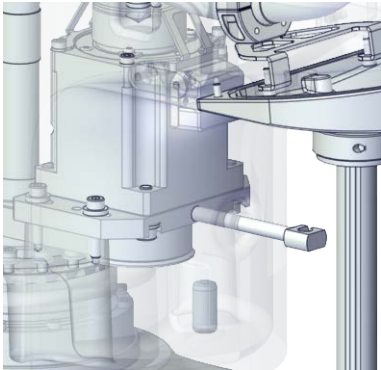



	Action	Note
2	Refit the axis-2 timing belt onto the pulley on the axis-2 gearbox.	Screws: Hex socket head cap screw M4x20 12.9 Lafre 2C2B/FC6.9 (4 pcs)
3	Refit the motor and refit the timing belt to the motor. Ensure that the belt runs correctly in the grooves.  Tip Move the internal harness out of the way.	Washers: Washer 4.3x10x2 steel (4 pcs) Tightening torque: 3 Nm ±10% 
4	Refit the screws and washers without fully tightened.	xx1800002877 Timing belt: 3HAC061861-001
5	Remove the plug.	 xx1800002878
6	Install the axis-1&2 belt tension adjustment tool to the motor through the hole.  Note Just tighten the tool.	Belt tension adjustment tool set, axis 1&2:-  xx1800002879

Continues on next page

5 Repair

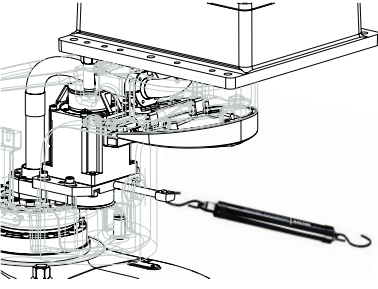
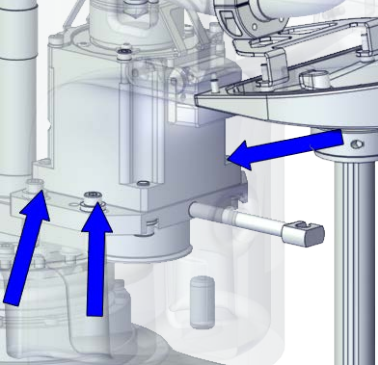

5.5.2 Replacing the axis-2 timing belt

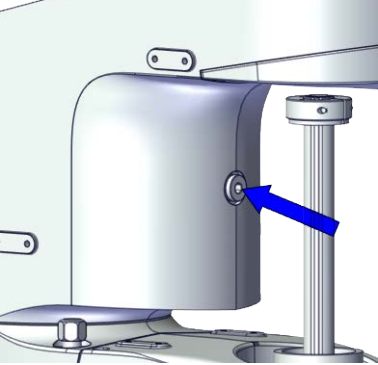
Continued

	Action	Note
7	<p>Use a handheld dynamometer hooking to the screw and pull the dynamometer to make the tension falling in the allowed force range.</p> <p> Note</p> <p>During the measurement, make sure that all interferences that may affect the force are removed. Pay attention to the force application direction.</p> <p> Tip</p> <p>If the ball screw will interfere with the handheld dynamometer, adjust the ball screw manually.</p>	<p>Used belt: 45-51N New belt:65-71N</p>  <p>xx190000095</p>
8	<p>Fasten the screws to the recommended tightening torque.</p>	<p>Tightening torque: 3 Nm \pm10%</p>  <p>xx1800002880</p>
9	<p>Use a sonic tension meter to measure the timing belt tension.</p>	<p>Used belt: 193-236Hz New belt:229-293Hz</p>
10	<p>If the timing belt tension does not meet the requirement, loosen the motor screws and readjust.</p>	
11	<p>Remove the axis-1&2 belt tension adjustment tool.</p>	
12	<p>Refit the plug.</p> <p> Tip</p> <p>Just tighten it.</p>	<p>Tightening torque: 2 Nm \pm10%</p>  <p>xx1800002878</p>

Continues on next page

Inserting the internal harness through the axis -2 gearbox position

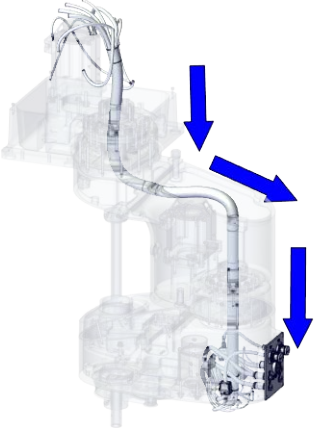
	Action	Note
1	<p>For robots with protection type Clean Room: Clean the joints that have been opened and wipe the parts free from particles with spirit on a lint free. See Cut the paint or surface on the robot before replacing parts on page 118</p> <p> Note</p> <p>After all repair work, wipe the Clean Room robot free from particles with spirit on a lint free cloth.</p>	
2	<p>Insert the internal harness into the outer arm through the centre of the axis-2 gearbox.</p> <p> Tip</p> <p>Wrap the connectors with the masking tape.</p>	 <p>xx1800003412</p>
3	Secure the R2.MP3 and R2.MP4 with cable straps.	

Refitting the cable bracket





	Action	Note
1	<p>For robots with protection type Clean Room: Clean the joints that have been opened and wipe the parts free from particles with spirit on a lint free. See Cut the paint or surface on the robot before replacing parts on page 118</p> <p> Note</p> <p>After all repair work, wipe the Clean Room robot free from particles with spirit on a lint free cloth.</p>	

Continues on next page

5 Repair

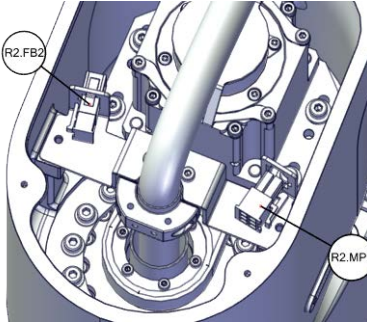

5.5.2 Replacing the axis-2 timing belt

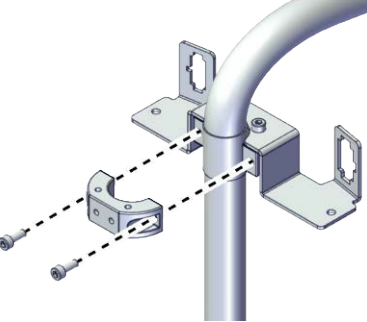
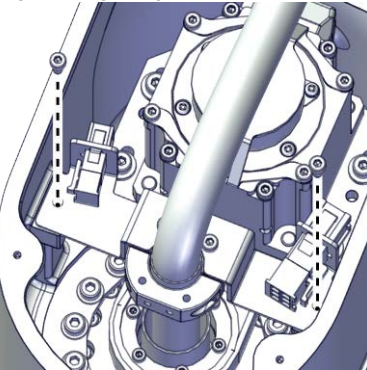
Continued

	Action	Note
2	<p>Reconnect the connectors.</p> <ul style="list-style-type: none"> • R2.MP2 • R2.FB2 <p> Tip</p> <p>Take photos of the connector and cable position before disconnecting them, to have as a reference when reconnecting.</p> <p> Tip</p> <p>See the number markings on the connectors for help to find the corresponding connector.</p>	 <p>xx1800002875</p>
3	<p>Lay the internal harness in a natural state without distortion.</p>	
4	<p>Refit the cable ferrule on the cable at the marked position and secure with screws.</p> <p> Tip</p> <p>The position with wrapped tape is the marked position for the cable ferrule.</p> <p> Tip</p> <p>Align all the cable ferrules so that the cable is in a natural bending position to avoid twisting.</p>	<p>Screws: Hex socket head cap screw M3x8 12.9 Lafre 2C2B/FC6.9 (2 pcs)</p> <p>Tightening torque: 1.5 Nm ±10%</p>  <p>xx1800002876</p>
5	<p>Refit the bracket and secure with the screws.</p>	<p>Screws: Hex socket head cap screw M3x5 12.9 Lafre 2C2B/FC6.9 (2 pcs)</p> <p>Tightening torque: 1.5 Nm ±10%</p>  <p>xx1800002874</p>

Continues on next page

Refitting the casting cover of the inner arm

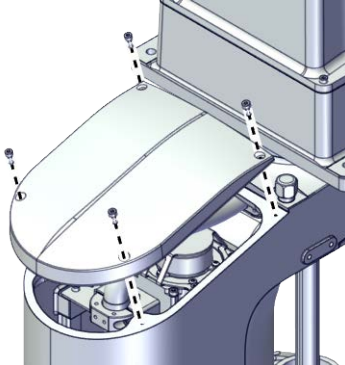
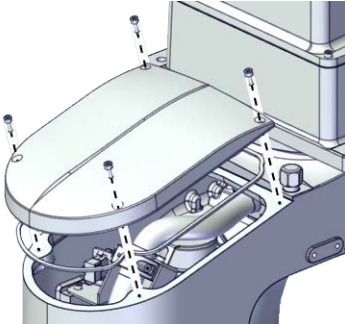
	Action	Note
1	<p>For robots with protection type Clean Room: Clean the joints that have been opened and wipe the parts free from particles with spirit on a lint free. See Cut the paint or surface on the robot before replacing parts on page 118</p> <p> Note</p> <p>After all repair work, wipe the Clean Room robot free from particles with spirit on a lint free cloth.</p>	
2	<p>Refit the casting cover.</p> <p> Note</p> <p>For robots with protection class IP54 (option 3350-540)</p> <p>For robots with protection type Clean Room (option 3351-1)</p> <p>Check the gasket for the casting cover before refitting the base cover.</p> <p> Tip</p> <p>Replace the gasket if needed.</p>	<p>Screw: Hex socket head cap screw M3x8 12.9 Lafre 2C2B/FC6.9 (4 pcs)</p> <p>Tightening torque: 1.2 Nm ±10%</p> <p>For robots with protection class IP30 (option 3350-300)</p>  <p>xx1800002873</p>
3	<p>Refit the screws.</p>	<p>For robots with protection class IP54 (option 3350-540)</p> <p>For robots with protection type Clean Room (option 3351-1)</p>  <p>xx1900001637</p>







Continues on next page

5 Repair

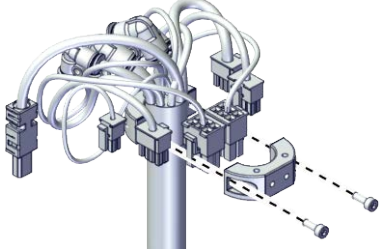

5.5.2 Replacing the axis-2 timing belt

Continued

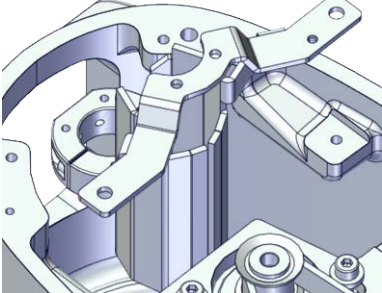
Refitting the cable ferrule and protected bracket

	Action	Note
1	<p>For robots with protection type Clean Room: Clean the joints that have been opened and wipe the parts free from particles with spirit on a lint free. See Cut the paint or surface on the robot before replacing parts on page 118</p> <p> Note</p> <p>After all repair work, wipe the Clean Room robot free from particles with spirit on a lint free cloth.</p>	
2	<p>Lay the internal harness in a natural state without distortion.</p>	
3	<p>Refit the cable ferrule and secure it with the screws.</p> <p> Tip</p> <p>The air hoses should face the process hub side.</p> <p> Tip</p> <p>The position with wrapped tape is the marked position for the cable ferrule.</p> <p> Tip</p> <p>Align all the cable ferrules so that the cable is in a natural bending position to avoid twisting.</p>	<p>Screws: Hex socket head cap screw M3x8 12.9 Lafre 2C2B/FC6.9 (2 pcs) Tightening torque: 1.5 Nm \pm10%</p>  <p>xx1800002849</p>
4	<p>Refit the protected bracket.</p> <p> Tip</p> <p>Do not secure it with the screws before the cable ferrule installed well.</p> <p> Note</p> <p>The harness are not visible due to the cleanliness requirements of the illustration. They are still existing inside the cable ferrule in the actual situation.</p>	<p>Screws: Hex socket head cap screw M4x8 12.9 Lafre 2C2B/FC6.9 (2 pcs) Tightening torque: 4 Nm \pm10%</p>  <p>xx1900000078</p>

Continues on next page

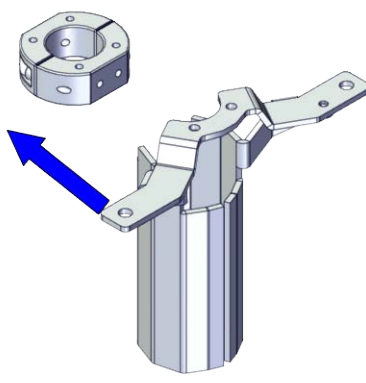
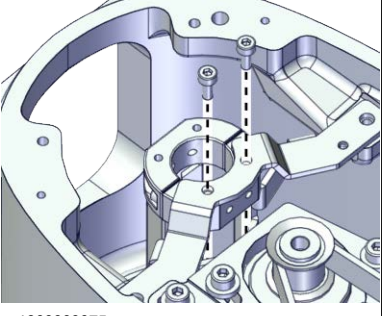
	Action	Note
5	<p>Secure the cable ferrule to the protected bracket.</p> <p> Tip</p> <p>Align all the cable ferrules so that the cable is in a natural bending position to avoid twisting.</p> <p> Note</p> <p>The harness are not visible due to the cleanness requirements of the illustration. They are still existing inside the cable ferrule in the actual situation.</p>	<p>Screws: Hex socket head cap screw M3x5 12.9 Lafre 2C2B/FC6.9 (2 pcs)</p> <p>Tightening torque: 1.5 Nm ±10%</p>  <p>xx1900000076</p>  <p>xx1900000075</p>





Reconnecting the connector for PB

	Action	Note
1	<p>For robots with protection type Clean Room: Clean the joints that have been opened and wipe the parts free from particles with spirit on a lint free. See Cut the paint or surface on the robot before replacing parts on page 118</p> <p> Note</p> <p>After all repair work, wipe the Clean Room robot free from particles with spirit on a lint free cloth.</p>	

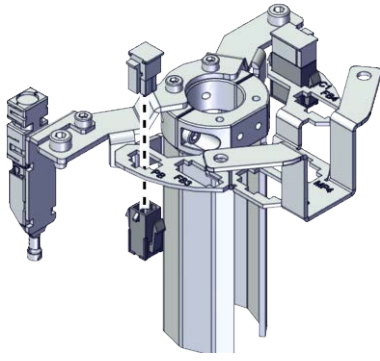

5 Repair

5.5.2 Replacing the axis-2 timing belt

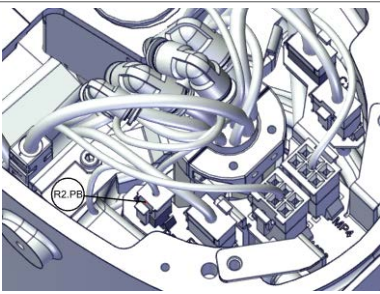





Continued

	Action	Note
2	<p>Insert the female head of the PB connector to the bracket accordingly.</p> <p> Tip</p> <p>The mistake proofing measure has been applied to the connectors, the connectors may be damaged if excessive force is used.</p> <p> Note</p> <p>The harness are not visible due to the cleanness requirements of the illustration. They are still existing inside the cable ferrule in the actual situation.</p>	 <p>xx1900000069</p>
3	<p>Reconnect the connector.</p> <ul style="list-style-type: none"> • R2.PB <p> Tip</p> <p>See the number markings on the connectors for help to find the corresponding connector.</p>	 <p>xx1900000068</p>

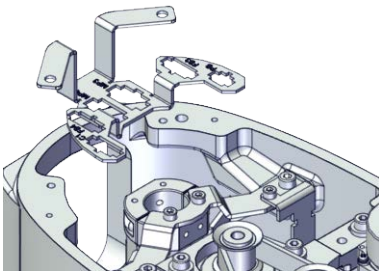
Reconnecting the air hoses, CP/CS cabling and Ethernet cabling (if equipped)

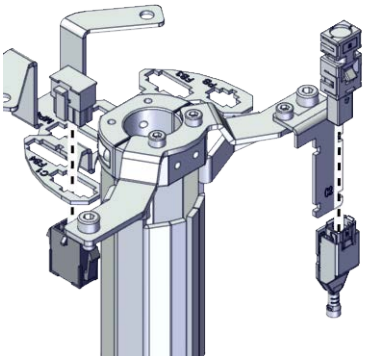
	Action	Note
1	<p>For robots with protection type Clean Room: Clean the joints that have been opened and wipe the parts free from particles with spirit on a lint free. See Cut the paint or surface on the robot before replacing parts on page 118</p> <p> Note</p> <p>After all repair work, wipe the Clean Room robot free from particles with spirit on a lint free cloth.</p>	
2	<p>Route the air hoses on the process hub behind the protected bracket.</p> <p> CAUTION</p> <p>Correct cable routing is highly important. If the cables are routed and secured incorrectly the cables can be damaged.</p>	

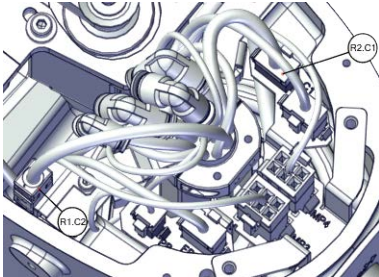
Continues on next page





	Action	Note
3	<p>Refit the bracket to the outer arm without screws.</p> <p> Note</p> <p>The harness are not visible due to the cleanness requirements of the illustration. They are still existing inside the cable ferrule in the actual situation.</p>	 <p>xx1900000073</p>
4	<p>Insert the female head of the C1 cabling connector to the bracket accordingly.</p> <p> Tip</p> <p>The mistake proofing measure has been applied to the connectors, the connectors may be damaged if excessive force is used.</p>	 <p>xx1900000071</p>
5	<p>For robots with C1 cabling</p> <p>Reconnect the connector.</p> <ul style="list-style-type: none"> • R2.C1 <p> Tip</p> <p>See the number markings on the air hoses for help to find the corresponding air hoses. The air hoses with the same number connect to the same L-shaped connector.</p> <p> Note</p> <p>The harness are not visible due to the cleanness requirements of the illustration. They are still existing inside the cable ferrule in the actual situation.</p>	 <p>xx1900000070</p>
6	<p>For robots with C2 cabling</p> <p>Reconnect the connector.</p> <ul style="list-style-type: none"> • R1.C2 <p> Tip</p> <p>See the number markings on the air hoses for help to find the corresponding air hoses. The air hoses with the same number connect to the same L-shaped connector.</p>	
7	<p>Secure the C2 cabling to the C2 bracket with the cable straps.</p>	

Continues on next page

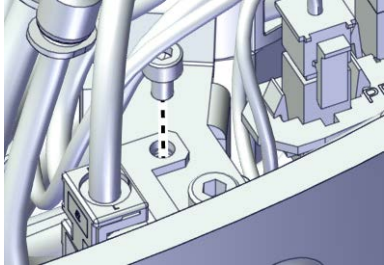

5 Repair

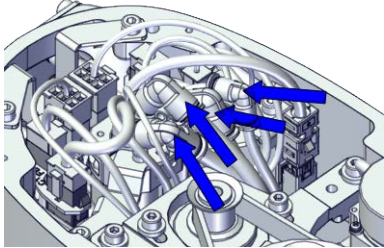
5.5.2 Replacing the axis-2 timing belt



Continued

	Action	Note
8	Secure the C2 bracket to the bracket with screw.	<p>Screws: Hex socket head cap screw M3x5 12.9 Lafre 2C2B/FC6.9 (1 pcs)</p> <p>Tightening torque: 4 Nm \pm10%</p>  <p>xx190000098</p>
9	<p>Reconnect the air hoses in a cross pattern with the L-shaped connectors.</p> <p> Tip</p> <p>See the number markings on the air hoses for help to find the corresponding air hoses. The air hoses with the same number connect to the same Y-shaped connector.</p>	 <p>xx1800002837</p>
10	<p>Route and secure the cabling with cable straps if needed.</p> <p> CAUTION</p> <p>Correct cable routing is highly important. If the cables are routed and secured incorrectly the cables can be damaged.</p>	

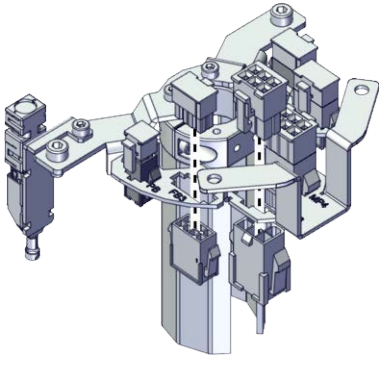

Reconnecting the connectors for axis-3 motor

	Action	Note
1	<p>For robots with protection type Clean Room: Clean the joints that have been opened and wipe the parts free from particles with spirit on a lint free. See Cut the paint or surface on the robot before replacing parts on page 118</p> <p> Note</p> <p>After all repair work, wipe the Clean Room robot free from particles with spirit on a lint free cloth.</p>	
2	<p>Route the cabling on the axis-3 motor behind the protected bracket to the bracket.</p> <p> CAUTION</p> <p>Correct cable routing is highly important. If the cables are routed and secured incorrectly the cables can be damaged.</p>	

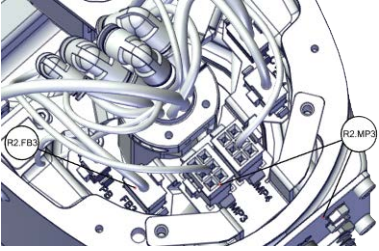
Continues on next page

	Action	Note
3	<p>Insert the female head of the connectors to the bracket accordingly.</p> <p> Tip</p> <p>The mistake proofing measure has been applied to the connectors, the connectors may be damaged if excessive force is used.</p>	 <p>xx1900000064</p>
4	<p>Reconnect the connectors.</p> <ul style="list-style-type: none"> • R2.MP3 • R2.FB3 <p> Tip</p> <p>See the number markings on the connectors for help to find the corresponding connector.</p>	 <p>xx1900000063</p>



Reconnecting the connectors for axis-4 motor

	Action	Note
1	<p>For robots with protection type Clean Room: Clean the joints that have been opened and wipe the parts free from particles with spirit on a lint free. See Cut the paint or surface on the robot before replacing parts on page 118</p> <p> Note</p> <p>After all repair work, wipe the Clean Room robot free from particles with spirit on a lint free cloth.</p>	
2	<p>Route the cabling on the axis-4 motor behind the protected bracket to the bracket.</p> <p> CAUTION</p> <p>Correct cable routing is highly important. If the cables are routed and secured incorrectly the cables can be damaged.</p>	

5 Repair

5.5.2 Replacing the axis-2 timing belt

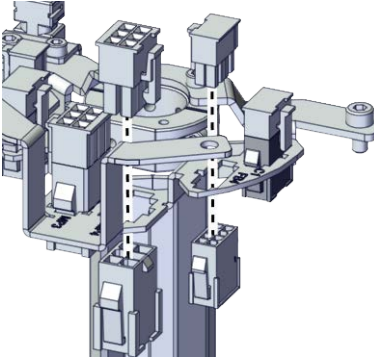
Continued

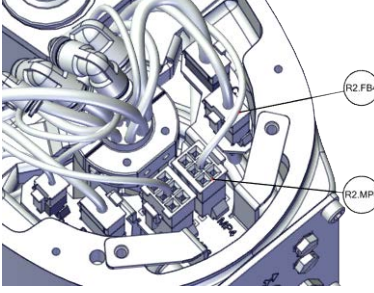
	Action	Note
	<p>Insert the female head of the connectors to the bracket accordingly.</p> <p> Tip</p> <p>The mistake proofing measure has been applied to the connectors, the connectors may be damaged if excessive force is used.</p>	 <p>xx1900000066</p>
3	<p>Reconnect the connectors.</p> <ul style="list-style-type: none"> • R2.MP4 • R2.FB4 <p> Tip</p> <p>See the number markings on the connectors for help to find the corresponding connector.</p>	 <p>xx1900000065</p>

Refitting the bracket for the process hub

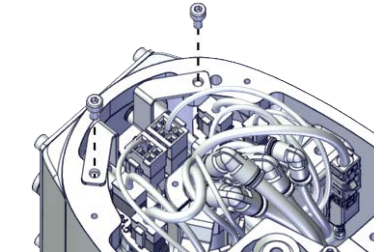
	Action	Note
1	<p>For robots with protection type Clean Room: Clean the joints that have been opened and wipe the parts free from particles with spirit on a lint free. See Cut the paint or surface on the robot before replacing parts on page 118</p> <p> Note</p> <p>After all repair work, wipe the Clean Room robot free from particles with spirit on a lint free cloth.</p>	
2	<p>Secure the bracket with screws.</p>	<p>Screws: Hex socket head cap screw M4x8 12.9 Lafre 2C2B/FC6.9 (2 pcs) Tightening torque: 4 Nm ±10%</p>  <p>xx1800002839</p>

Continues on next page

Refitting the cover of the outer arm



	Action	Note
1	<p>For robots with protection type Clean Room: Clean the joints that have been opened and wipe the parts free from particles with spirit on a lint free. See Cut the paint or surface on the robot before replacing parts on page 118</p> <p> Note</p> <p>After all repair work, wipe the Clean Room robot free from particles with spirit on a lint free cloth.</p>	

Continues on next page

5 Repair

5.5.2 Replacing the axis-2 timing belt

Continued

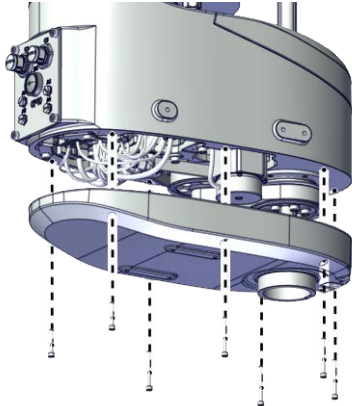
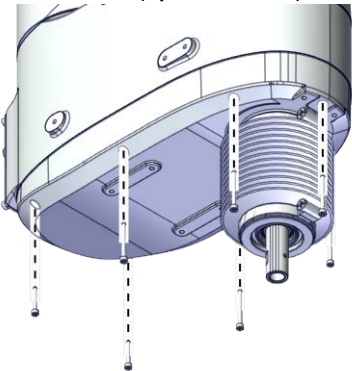
	Action	Note
2	<p>Refit the cover.</p> <p> Note</p> <p>For robots with protection class IP54 (option 3350-540)</p> <p>For robots with protection type Clean Room (option 3351-1)</p> <p>Refit the cover with bellow and housing.</p> <p>Check the gasket on the outer arm cover.</p> <p> Tip</p> <p>Replace the gasket if needed.</p>	<p>For IRB 910INV-3/0.35:</p> <p>Screw: Hex socket head cap screw M3x20 12.9 Lafre 2C2B/FC6.9 (2 pcs)</p> <p>Hex socket head cap screw M3x30 12.9 Lafre 2C2B/FC6.9 (5 pcs)</p> <p>Tightening torque: 1.2 Nm ±10%</p> <p>For IRB 910INV-6/0.55:</p> <p>Screw: Hex socket head cap screw M3x20 12.9 Lafre 2C2B/FC6.9 (2 pcs)</p> <p>Hex socket head cap screw M3x30 12.9 Lafre 2C2B/FC6.9 (7 pcs)</p> <p>Tightening torque: 1.2 Nm ±10%</p>
3	<p>Refit the screws.</p>	<p>For robots with protection class IP30 (option 3350-300)</p>  <p>xx1800002836</p> <p>For robots with protection class IP54 (option 3350-540)</p> <p>For robots with protection type Clean Room (option 3351-1)</p>  <p>xx1900001631</p>

Continues on next page

Refitting the lower cover

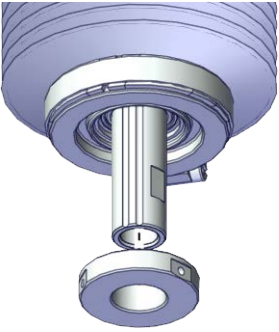
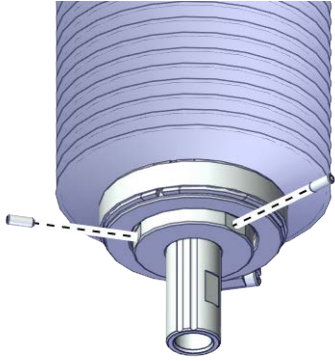
	Action	Note
1	<p>For robots with protection type Clean Room: Clean the joints that have been opened and wipe the parts free from particles with spirit on a lint free. See Cut the paint or surface on the robot before replacing parts on page 118</p> <p> Note</p> <p>After all repair work, wipe the Clean Room robot free from particles with spirit on a lint free cloth.</p>	
2	<p>For robots with protection class IP54 (option 3350-540) For robots with protection type Clean Room (option 3351-1) Refit the lower cover to the ball screw.</p>	 <p>xx1900001607</p>
3	<p>For robots with protection class IP54 (option 3350-540) For robots with protection type Clean Room (option 3351-1) Refit the locking screws.</p>	<p>Screws: Hexagon socket set screws with flat point, ISO 4026 stainless steel M3x8 (2 pcs) Tightening torque: 0.6 Nm ±10%</p>  <p>xx1900001606</p>



Continues on next page

5 Repair

5.5.2 Replacing the axis-2 timing belt

Continued

Concluding procedure

	Action	Note
1	<p>For robots with protection type Clean Room: Seal and paint the joints that have been opened. See Cut the paint or surface on the robot before replacing parts on page 118</p> <p> Note</p> <p>After all repair work, wipe the Clean Room robot free from particles with spirit on a lint free cloth.</p>	
2	Recalibrate the robot.	Calibration is detailed in section Calibration on page 771 .
3	<p> DANGER</p> <p>Make sure all safety requirements are met when performing the first test run. See Test run after installation, maintenance, or repair on page 56.</p>	

5.6 Outer arm

5.6.1 Replacing the mechanical stopper

Location of the mechanical stoppers

The mechanical stoppers are located as shown in the figure.

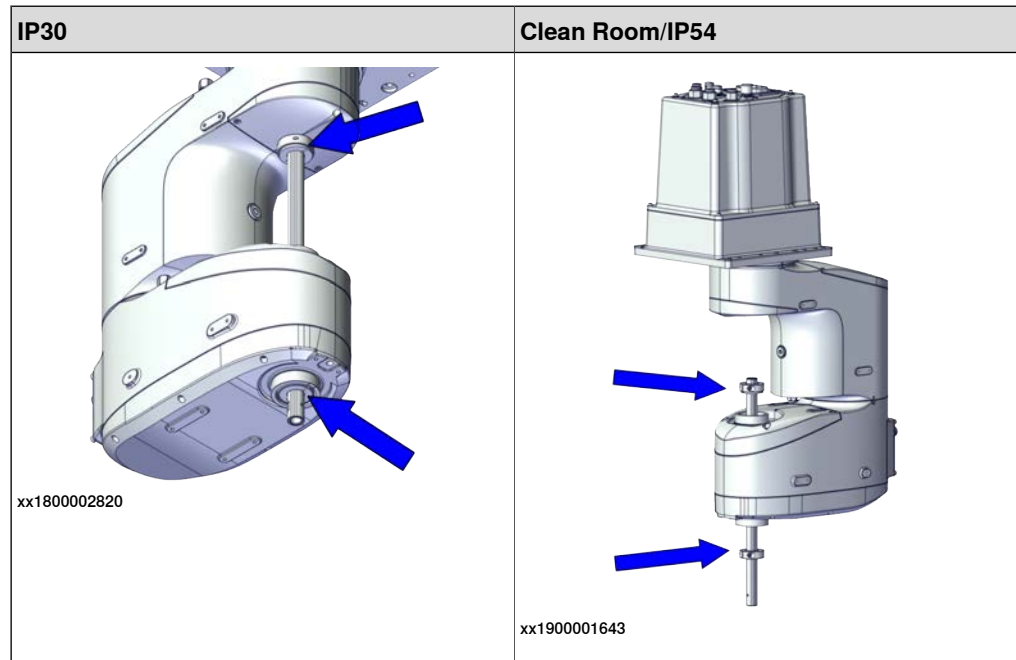

CAUTION

For the robots with protection type Clean Room and protection class IP54, the mechanical stops are inside the bellows. If needed, remove the bellows to inspect the ball screw spline unit.

For the details on removing the bellows, refer to [Replacing the bellows](#).

Required spare parts



Note

The spare part numbers that are listed in the table can be out of date. See the latest spare parts of the IRB 910INV via myABB Business Portal, www.abb.com/myABB.

Spare part	Article number	Note
Mechanical-Stop top, D16	3HAC073060-001	Used for IRB 910INV-3/0.35
Mechanical-Stop top, D20	3HAC073068-001	Used for IRB 910INV-6/0.55
Mechanical-Stop bottom, D16	3HAC073061-001	Used for IRB 910INV-3/0.35
Mechanical-Stop bottom, D20	3HAC073069-001	Used for IRB 910INV-6/0.55

Continues on next page

5 Repair

5.6.1 Replacing the mechanical stopper

Continued

Required tools and equipment

Equipment	Article number	Note
Standard toolkit	-	Content is defined in section Standard toolkit on page 840 .
Calibration tool box, Axis Calibration	3HAC074119-001	Delivered as a set of calibration tools. Required if Axis Calibration is the valid calibration method for the robot. ⁱ
24 VDC power supply	-	Used to release the motor brakes.

ⁱ The robot is calibrated by either manual calibration or Axis Calibration at ABB factory before delivery. Always use the same calibration method as used at the factory.
Information about valid calibration method is found on the calibration label or in the calibration menu on the FlexPendant.
If no data is found related to standard calibration, manual calibration is used as default.

Required consumables

Consumable	Article number	Note
Cable straps	-	
Grease	-	THK AFA Used to lubricate the ball screw spline shaft.
Sealing compound	3HAC026759-002	Sikaflex 521 FC For robots with protection type Clean Room.

Deciding calibration routine

Decide which calibration routine to be used, based on the information in the table. Depending on which routine is chosen, action might be required prior to beginning the repair work of the robot, see the table.

	Action	Note
1	Decide which calibration routine to use for calibrating the robot. <ul style="list-style-type: none"> Reference calibration. External cable packages (DressPack) and tools can stay fitted on the robot. Fine calibration. All external cable packages (DressPack) and tools must be removed from the robot. 	
	<p>If the robot is to be calibrated with reference calibration:</p> <p>Find previous reference values for the axis or create new reference values. These values are to be used after the repair procedure is completed, for calibration of the robot.</p> <p>If no previous reference values exist, and no new reference values can be created, then reference calibration is not possible.</p>	<p>Follow the instructions given in the reference calibration routine on the FlexPendant to create reference values.</p> <p>Creating new values requires possibility to move the robot.</p> <p>Read more about reference calibration for Axis Calibration in Reference calibration routine on page 798.</p>



Continues on next page

Action	Note
<p>If the robot is to be calibrated with fine calibration: Remove all external cable packages (DressPack) and tools from the robot.</p>	

Removing the upper mechanical stopper

Use these procedures to remove the upper mechanical stopper.

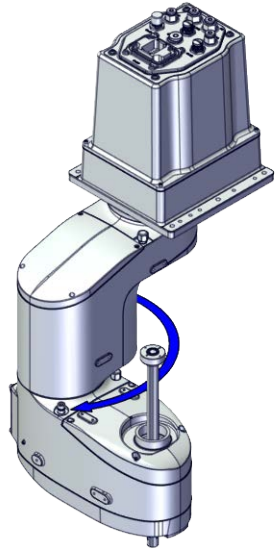
Preparations before removing the upper mechanical stopper

Action	Note
1	Decide which calibration routine to use, and take actions accordingly prior to beginning the repair procedure.
2	<p>Jog the outer arm to outer position to have enough space for the repair procedure.</p>  <p>xx1800003407</p>
3	<p> DANGER</p> <p>Turn off all:</p> <ul style="list-style-type: none"> • electric power supply • hydraulic pressure supply • air pressure supply <p>to the robot, before entering the safeguarded space.</p>
4	<p> CAUTION</p> <p>For robots with protection type Clean Room Always cut the paint with a knife and grind the paint edge when disassembling parts of the robot! See <i>Cut the paint or surface on the robot before replacing parts on page 118.</i></p>



Continues on next page

5 Repair

5.6.1 Replacing the mechanical stopper

Continued

Removing the upper cover

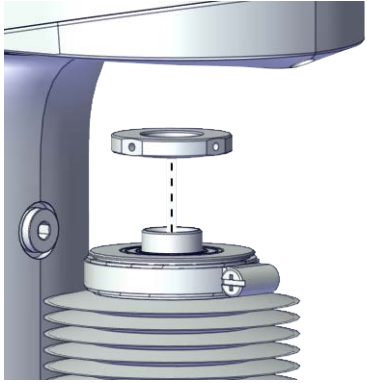



	Action	Note
1	 DANGER Make sure that all supplies for electrical power, hydraulic pressure, and air pressure are turned off.	
2	 CAUTION For robots with protection type Clean Room Always cut the paint with a knife and grind the paint edge when disassembling parts of the robot! See Cut the paint or surface on the robot before replacing parts on page 118 .	
3	For robots with protection class IP54 (option 3350-540) For robots with protection type Clean Room (option 3351-1) Loose the locking screws.	 <small>xx1900001547</small>
4	For robots with protection class IP54 (option 3350-540) For robots with protection type Clean Room (option 3351-1) Remove the upper cover from the ball screw.	 <small>xx1900001548</small>

Removing the casting cover of the outer arm with the bellow

	Action	Note
1	 DANGER Make sure that all supplies for electrical power, hydraulic pressure, and air pressure are turned off.	

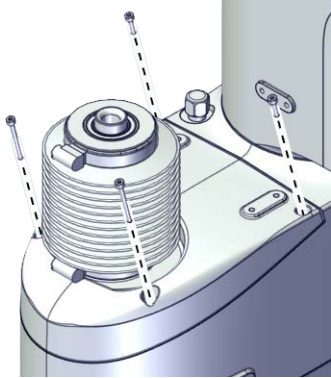
Continues on next page

5.6.1 Replacing the mechanical stopper
Continued

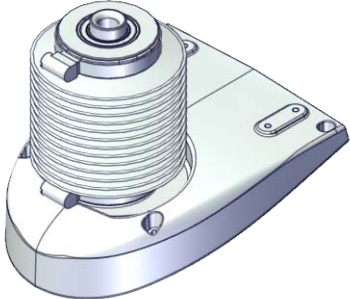
	Action	Note
2	<p> CAUTION</p> <p>For robots with protection type Clean Room Always cut the paint with a knife and grind the paint edge when disassembling parts of the robot! See <i>Cut the paint or surface on the robot before replacing parts on page 118.</i></p>	
3	<p>For robots with protection class IP54 (option 3350-540) For robots with protection type Clean Room (option 3351-1) Remove the screws on the casting cover of the outer arm.</p>	 <p>xx1900001628</p>
4	<p>For robots with protection class IP54 (option 3350-540) For robots with protection type Clean Room (option 3351-1) Remove the cover with bellow and housing.</p> <p> Tip</p> <p>In this way, do not need to remove/ refit the bellow to the cover and the housing.</p> <p> CAUTION</p> <p>There is a gasket in the cover. Be careful when removing the cover with bellow and housing.</p> <p> Tip</p> <p>Check the gasket and replace it if needed.</p>	 <p>xx1900001629</p>

Removing the extension shaft for Clean Room/ IP54 robots

	Action	Note
1	<p> DANGER</p> <p>Make sure that all supplies for electrical power, hydraulic pressure, and air pressure are turned off.</p>	

Continues on next page

5 Repair

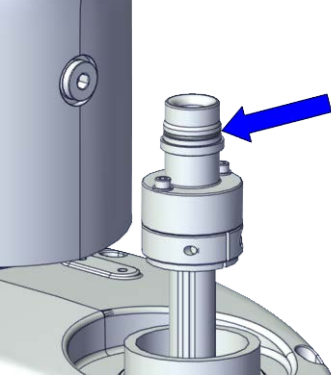
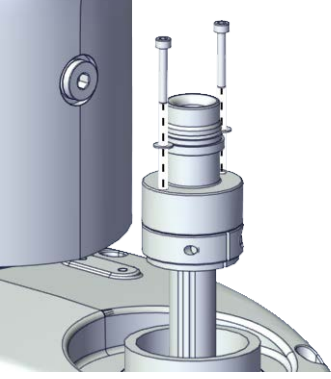
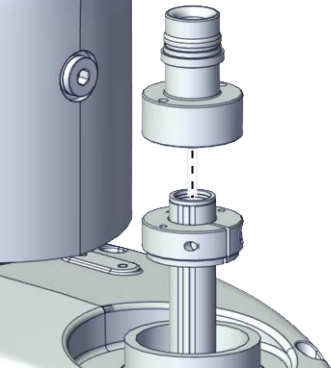

5.6.1 Replacing the mechanical stopper

Continued

	Action	Note
2	<p> CAUTION</p> <p>For robots with protection type Clean Room Always cut the paint with a knife and grind the paint edge when disassembling parts of the robot! See <i>Cut the paint or surface on the robot before replacing parts on page 118.</i></p>	
3	<p>For robots with protection class IP54 (option 3350-540) For robots with protection type Clean Room (option 3351-1) Remove the O-ring from the upper housing.</p>	 <p>xx1900001556</p>
4	<p>For robots with protection class IP54 (option 3350-540) For robots with protection type Clean Room (option 3351-1) Loose the attachment screws.</p>	 <p>xx1900001557</p>
5	<p>For robots with protection class IP54 (option 3350-540) For robots with protection type Clean Room (option 3351-1) Remove the extension shaft from the mechanical stopper.</p>	 <p>xx1900001558</p>

Continues on next page

Removing the upper mechanical stopper

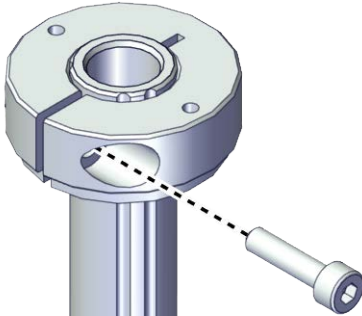
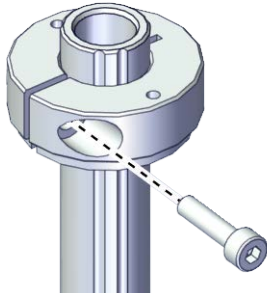

	Action	Note
1	 <p>DANGER</p> <p>Make sure that all supplies for electrical power, hydraulic pressure, and air pressure are turned off.</p>	
2	 <p>CAUTION</p> <p>For robots with protection type Clean Room Always cut the paint with a knife and grind the paint edge when disassembling parts of the robot! See <i>Cut the paint or surface on the robot before replacing parts on page 118.</i></p>	
3	Remove the screw.	<p>For robots with protection class IP30 (option 3350-300)</p>  <p>xx1800002858</p> <p>For robots with protection class IP54 (option 3350-540) For robots with protection type Clean Room (option 3351-1)</p>  <p>xx1900001640</p>

Continues on next page

5 Repair

5.6.1 Replacing the mechanical stopper

Continued

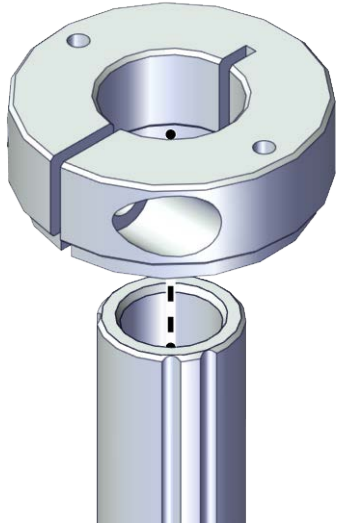
	Action	Note
4	<p>Remove the mechanical stopper.</p> <p> Tip</p> <p>Hold the ball screw to prevent it from dropping. Or the ball screw may be destroyed.</p> <p> CAUTION</p> <p>If the ball screw nut or ball screw spline nut go out of the screw shaft, the ball screw is destroyed. Be careful when you do any work that may cause this.</p>	 <p>xx1800002859</p>



Refitting the upper mechanical stopper

Use these procedures to refit the upper mechanical stopper.

Refitting the upper mechanical stopper

	Action	Note
1	<p>For robots with protection type Clean Room: Clean the joints that have been opened and wipe the parts free from particles with spirit on a lint free. See Cut the paint or surface on the robot before replacing parts on page 118</p> <p> Note</p> <p>After all repair work, wipe the Clean Room robot free from particles with spirit on a lint free cloth.</p>	

Continues on next page

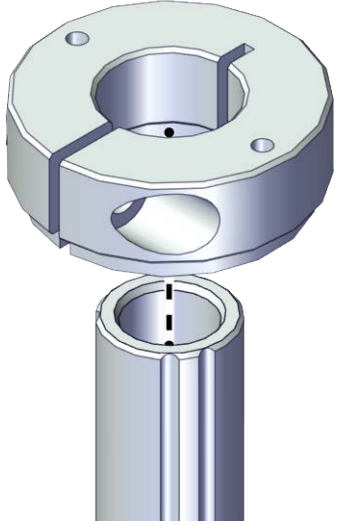
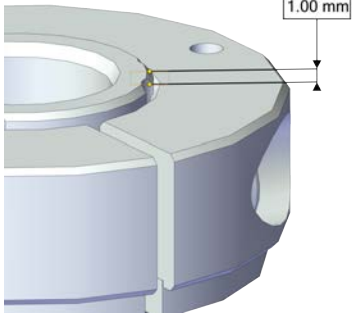
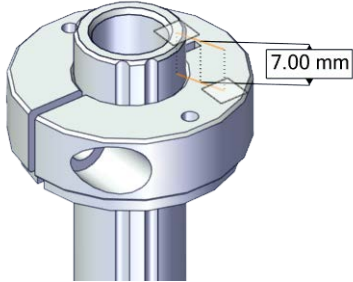
	Action	Note
2	<p>Refit the mechanical stopper to the ball screw at 1 mm position to the upper of the ball screw.</p> <p> Note</p> <p>For robots with protection class IP54 (option 3350-540) For robots with protection type Clean Room (option 3351-1) For IRB 910INV-3/0.35, refit the mechanical stopper to the ball screw at 7 mm position to the upper of the ball screw. For IRB 910INV-6/0.55, refit the mechanical stopper to the ball screw at 2 mm position to the upper of the ball screw.</p> <p> Tip</p> <p>Hold the ball screw to prevent it from dropping. Or the ball screw may be destroyed.</p> <p> CAUTION</p> <p>If the ball screw nut or ball screw spline nut go out of the screw shaft, the ball screw is destroyed. Be careful when you do any work that may cause this.</p>	 <p>xx1800002859</p> <p>For robots with protection class IP30 (option 3350-300)</p>  <p>xx1900002012</p> <p>For robots with protection class IP54 (option 3350-540) For robots with protection type Clean Room (option 3351-1) For IRB 910INV-3/0.35</p>  <p>xx1900001639</p> <p>For IRB 910INV-6/0.55</p>

Continues on next page

5 Repair

5.6.1 Replacing the mechanical stopper

Continued

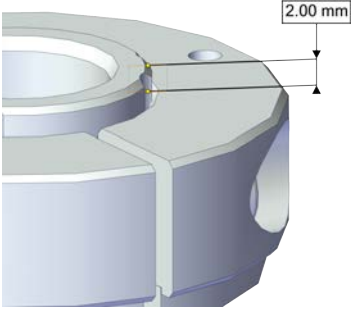
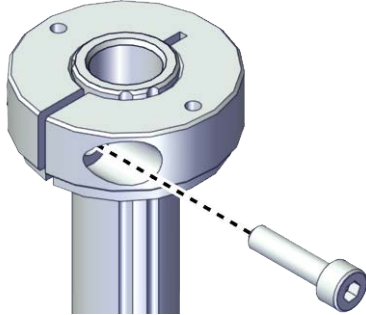
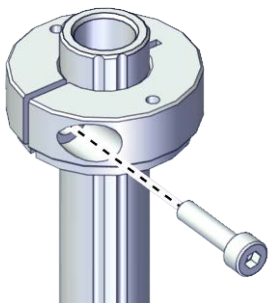
	Action	Note
		 <p>xx1900002011</p>
3	Refit the screw.	<p>Screws: Hex socket head cap screw M4x16 12.9 Lafre 2C2B/FC6.9 (1 pcs) Tightening torque: 6.5 Nm \pm10% For robots with protection class IP30 (option 3350-300)</p>  <p>xx1800002858</p> <p>For robots with protection class IP54 (option 3350-540) For robots with protection type Clean Room (option 3351-1)</p>  <p>xx1900001640</p>

Continues on next page

Refitting the extension shaft for Clean Room/ IP54 robots

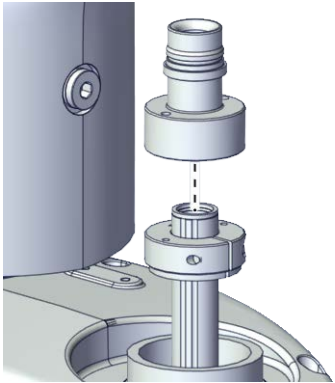
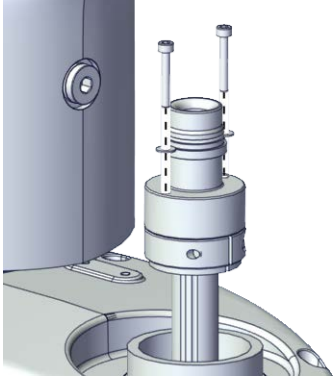
	Action	Note
1	<p>For robots with protection type Clean Room: Clean the joints that have been opened and wipe the parts free from particles with spirit on a lint free. See Cut the paint or surface on the robot before replacing parts on page 118</p> <p> Note</p> <p>After all repair work, wipe the Clean Room robot free from particles with spirit on a lint free cloth.</p>	
2	<p>For robots with protection class IP54 (option 3350-540)</p> <p>For robots with protection type Clean Room (option 3351-1)</p> <p>Install the extension shaft to the ball screw on the upper side of the mechanical stopper.</p>	 <p>xx1900001558</p>
3	<p>For robots with protection class IP54 (option 3350-540)</p> <p>For robots with protection type Clean Room (option 3351-1)</p> <p>Secure the extension shaft to the mechanical stopper with the screws.</p>	<p>For IRB 910INV-3/0.35: Screws: Hex socket head cap screw M3x20 12.9 Lafre 2C2B/FC6.9 (2 pcs) Tightening torque: 1.2 Nm ±10%</p> <p>For IRB 910INV-6/0.55: Screws: Hex socket head cap screw M3x20 12.9 Lafre 2C2B/FC6.9 (2 pcs) Tightening torque: 1.2 Nm ±10%</p>  <p>xx1900001557</p>

Continues on next page



5 Repair

5.6.1 Replacing the mechanical stopper

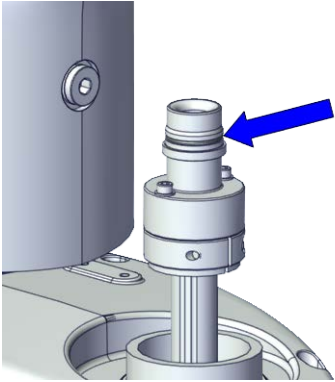
Continued

	Action	Note
4	<p>For robots with protection class IP54 (option 3350-540)</p> <p>For robots with protection type Clean Room (option 3351-1)</p> <p>Insert the O-ring to the extension shaft.</p>	 <p>xx1900001556</p>

Refitting the casting cover of the outer arm with the bellow

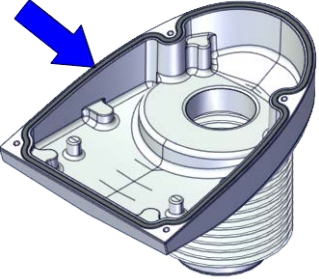
	Action	Note
1	<p>For robots with protection type Clean Room:</p> <p>Clean the joints that have been opened and wipe the parts free from particles with spirit on a lint free. See Cut the paint or surface on the robot before replacing parts on page 118</p> <p> Note</p> <p>After all repair work, wipe the Clean Room robot free from particles with spirit on a lint free cloth.</p>	
2	<p>For robots with protection class IP54 (option 3350-540)</p> <p>For robots with protection type Clean Room (option 3351-1)</p> <p>Check the gasket on the casting cover.</p> <p> Tip</p> <p>Replace the gasket if needed.</p>	 <p>xx1900001630</p>

Continues on next page

5.6.1 Replacing the mechanical stopper Continued

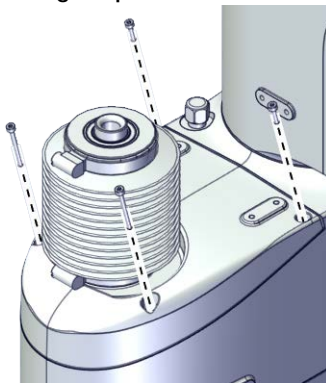
	Action	Note
3	<p>For robots with protection class IP54 (option 3350-540)</p> <p>For robots with protection type Clean Room (option 3351-1)</p> <p>Refit the cover with bellow and housing.</p> <p> Tip</p> <p>In this way, do not need to remove/ refit the bellow to the cover and the housing.</p>	<p>Long screw: Hex socket head cap screw M3x30 12.9 Lafre 2C2B/FC6.9 (2 pcs)</p> <p>Tightening torque: 1.2 Nm ±10%</p> <p>Short screw: Hex socket head cap screw M3x12 12.9 Lafre 2C2B/FC6.9 (2 pcs)</p> <p>Tightening torque: 1.2 Nm ±10%</p>
4	<p>For robots with protection class IP54 (option 3350-540)</p> <p>For robots with protection type Clean Room (option 3351-1)</p> <p>Refit the screws.</p>	 <p>xx1900001628</p>

Refitting the upper cover

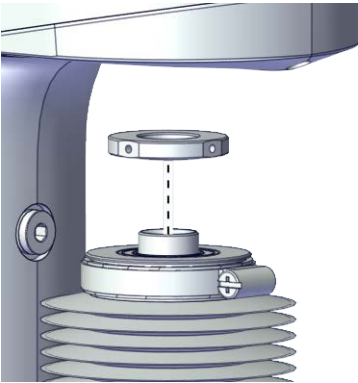
	Action	Note
1	<p>For robots with protection type Clean Room:</p> <p>Clean the joints that have been opened and wipe the parts free from particles with spirit on a lint free. See Cut the paint or surface on the robot before replacing parts on page 118</p> <p> Note</p> <p>After all repair work, wipe the Clean Room robot free from particles with spirit on a lint free cloth.</p>	
2	<p>For robots with protection class IP54 (option 3350-540)</p> <p>For robots with protection type Clean Room (option 3351-1)</p> <p>Refit the upper cover to the ball screw.</p>	 <p>xx1900001548</p>

Continues on next page



5 Repair

5.6.1 Replacing the mechanical stopper

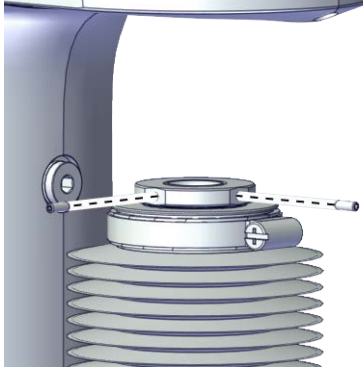
Continued

	Action	Note
3	<p>For robots with protection class IP54 (option 3350-540)</p> <p>For robots with protection type Clean Room (option 3351-1)</p> <p>Refit the locking screws.</p>	<p>Screws: Hexagon socket set screws with flat point, ISO 4026 stainless steel M3x8 (2 pcs)</p> <p>Tightening torque: 0.6 Nm \pm10%</p>  <p>xx1900001547</p>

Concluding procedure

	Action	Note
1	<p>For robots with protection type Clean Room:</p> <p>Seal and paint the joints that have been opened. See Cut the paint or surface on the robot before replacing parts on page 118</p> <p> Note</p> <p>After all repair work, wipe the Clean Room robot free from particles with spirit on a lint free cloth.</p>	
2	<p> DANGER</p> <p>Make sure all safety requirements are met when performing the first test run. See Test run after installation, maintenance, or repair on page 56.</p>	



Removing the lower mechanical stopper

Use these procedures to remove the lower mechanical stopper.



Preparations before removing the lower mechanical stopper

	Action	Note
1	Decide which calibration routine to use, and take actions accordingly prior to beginning the repair procedure.	
2	Move the ball screw to lower position.	

Continues on next page

	Action	Note
3	 DANGER Turn off all: <ul style="list-style-type: none"> • electric power supply • hydraulic pressure supply • air pressure supply to the robot, before entering the safeguarded space.	
4	 CAUTION For robots with protection type Clean Room Always cut the paint with a knife and grind the paint edge when disassembling parts of the robot! See Cut the paint or surface on the robot before replacing parts on page 118 .	

Removing the lower cover

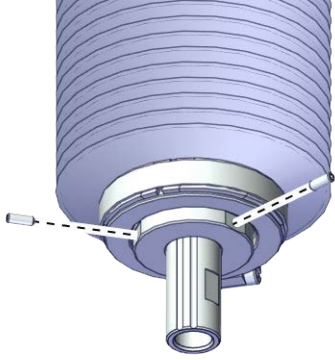
	Action	Note
1	 DANGER Make sure that all supplies for electrical power, hydraulic pressure, and air pressure are turned off.	
2	 CAUTION For robots with protection type Clean Room Always cut the paint with a knife and grind the paint edge when disassembling parts of the robot! See Cut the paint or surface on the robot before replacing parts on page 118 .	
3	For robots with protection class IP54 (option 3350-540) For robots with protection type Clean Room (option 3351-1) Loose the locking screws.	 xx1900001606

Continues on next page



5 Repair

5.6.1 Replacing the mechanical stopper

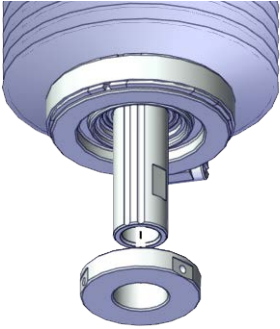

Continued

	Action	Note
4	<p>For robots with protection class IP54 (option 3350-540)</p> <p>For robots with protection type Clean Room (option 3351-1)</p> <p>Remove the lower cover from the ball screw.</p>	 <p>xx1900001607</p>

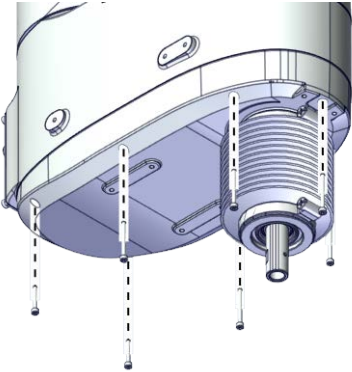

Removing the cover of the outer arm with the bellow

	Action	Note
1	 <p>DANGER</p> <p>Make sure that all supplies for electrical power, hydraulic pressure, and air pressure are turned off.</p>	
2	 <p>CAUTION</p> <p>For robots with protection type Clean Room</p> <p>Always cut the paint with a knife and grind the paint edge when disassembling parts of the robot! See Cut the paint or surface on the robot before replacing parts on page 118.</p>	
3	<p>For robots with protection class IP54 (option 3350-540)</p> <p>For robots with protection type Clean Room (option 3351-1)</p> <p>Remove the screws on the cover of the outer arm.</p>	 <p>xx1900001631</p>

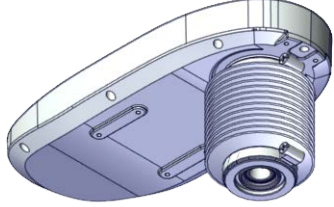
Continues on next page

	Action	Note
4	<p>For robots with protection class IP54 (option 3350-540) For robots with protection type Clean Room (option 3351-1) Remove the cover with bellow and housing.</p> <p> Note</p> <p>The bellow does not need to be removed separately.</p> <p> CAUTION</p> <p>There is a gasket in the cover. Be careful when removing the cover with bellow and housing.</p> <p> Tip</p> <p>Check the gasket and replace it if needed.</p>	 <p>xx1900001632</p>

Removing the shaft for Clean Room/ IP54 robots

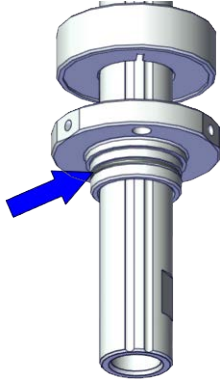

	Action	Note
1	<p> DANGER</p> <p>Make sure that all supplies for electrical power, hydraulic pressure, and air pressure are turned off.</p>	
2	<p> CAUTION</p> <p>For robots with protection type Clean Room Always cut the paint with a knife and grind the paint edge when disassembling parts of the robot! See Cut the paint or surface on the robot before replacing parts on page 118.</p>	
3	<p>For robots with protection class IP54 (option 3350-540) For robots with protection type Clean Room (option 3351-1) Remove the O-ring from the lower housing.</p>	 <p>xx1900001615</p>

Continues on next page

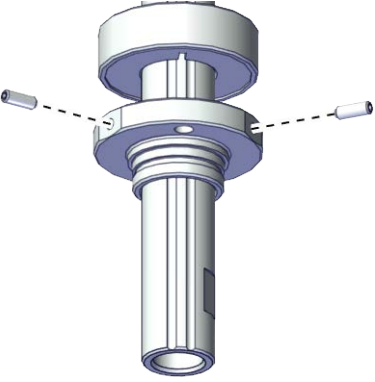

5 Repair

5.6.1 Replacing the mechanical stopper

Continued



	Action	Note
4	<p>For robots with protection class IP54 (option 3350-540)</p> <p>For robots with protection type Clean Room (option 3351-1)</p> <p>Loose the attachment screws.</p>	 <p>xx1900001616</p>
5	<p>For robots with protection class IP54 (option 3350-540)</p> <p>For robots with protection type Clean Room (option 3351-1)</p> <p>Remove the shaft from the mechanical stopper.</p> <p> Note</p> <p>The shaft is glued to the ball screw. Be careful with the glue when removing the shaft.</p>	

Removing the lower mechanical stopper

	Action	Note
1	<p> DANGER</p> <p>Make sure that all supplies for electrical power, hydraulic pressure, and air pressure are turned off.</p>	
2	<p> CAUTION</p> <p>For robots with protection type Clean Room</p> <p>Always cut the paint with a knife and grind the paint edge when disassembling parts of the robot! See Cut the paint or surface on the robot before replacing parts on page 118.</p>	

Continues on next page

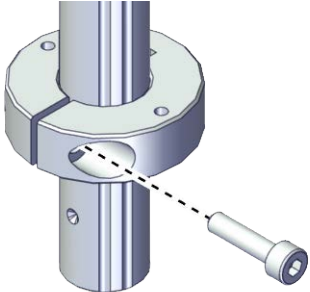
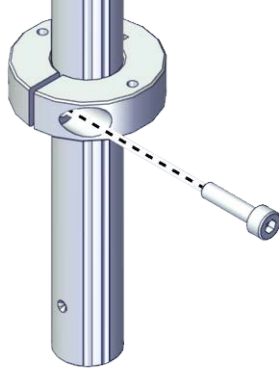
5.6.1 Replacing the mechanical stopper
Continued

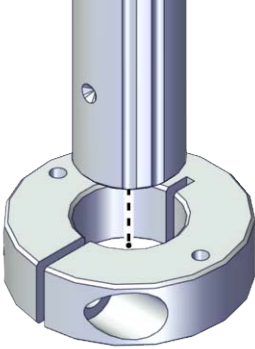
	Action	Note
3	Remove the screw.	<p>For robots with protection class IP30 (option 3350-300)</p>  <p>xx1800002860</p> <p>For robots with protection class IP54 (option 3350-540) For robots with protection type Clean Room (option 3351-1)</p>  <p>xx1900001642</p>
4	<p>Remove the mechanical stopper.</p> <p> CAUTION</p> <p>If the ball screw nut or ball screw spline nut go out of the screw shaft, the ball screw is destroyed. Be careful when you do any work that may cause this.</p>	 <p>xx1800002861</p>

Continues on next page

5 Repair

5.6.1 Replacing the mechanical stopper

Continued





Refitting the lower mechanical stopper

Use these procedures to refit the lower mechanical stopper.

Refitting the mechanical stopper

	Action	Note
1	<p>For robots with protection type Clean Room: Clean the joints that have been opened and wipe the parts free from particles with spirit on a lint free. See Cut the paint or surface on the robot before replacing parts on page 118</p> <p> Note</p> <p>After all repair work, wipe the Clean Room robot free from particles with spirit on a lint free cloth.</p>	

Continues on next page

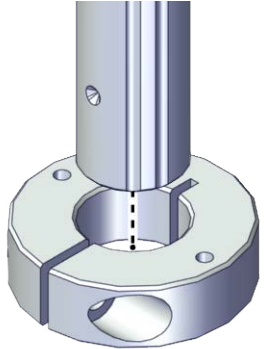
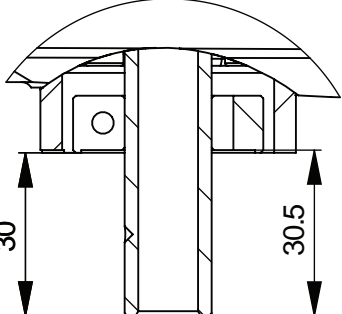
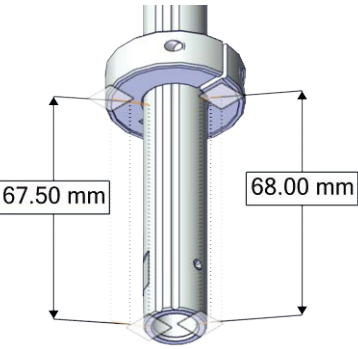
	Action	Note
2	<p>Refit the mechanical stopper to the ball screw at 30.5 mm position to the lower of the ball screw.</p> <p> Note</p> <p>For robots with protection class IP54 (option 3350-540) For robots with protection type Clean Room (option 3351-1) For IRB 910INV-3/0.35, refit the mechanical stopper to the ball screw at 68 mm position to the lower of the ball screw. For IRB 910INV-6/0.55, refit the mechanical stopper to the ball screw at 75.8 mm position to the lower of the ball screw.</p> <p> Tip</p> <p>Make sure that the limit block opening gap is aligned with the ball screw origin point.</p> <p> CAUTION</p> <p>If the ball screw nut or ball screw spline nut go out of the screw shaft, the ball screw is destroyed. Be careful when you do any work that may cause this.</p> <p> Note</p> <p>Be careful with the orientation of the mechanical stopper. The flat side is on the upper side.</p>	 <p>xx1800002861</p> <p>For robots with protection class IP30 (option 3350-300)</p>  <p>xx1900000144</p> <p>For robots with protection class IP54 (option 3350-540) For robots with protection type Clean Room (option 3351-1) For IRB 910INV-3/0.35</p>  <p>xx1900001641</p> <p>For IRB 910INV-6/0.55</p>

Continues on next page

5 Repair

5.6.1 Replacing the mechanical stopper

Continued

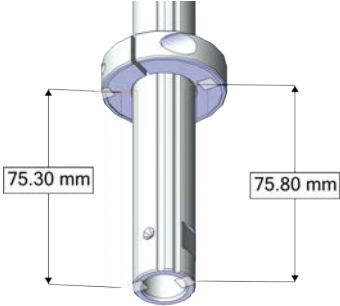
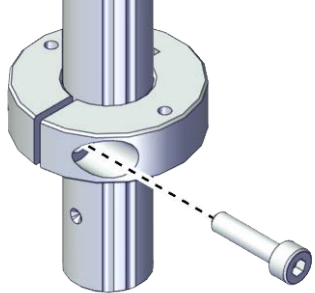
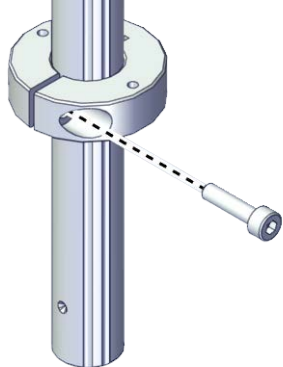
	Action	Note
		 <p data-bbox="1027 636 1134 656">xx1900002004</p>
3	Refit the screw.	<p data-bbox="1027 689 1390 775">Screws: Hex socket head cap screw M4x16 12.9 Lafre 2C2B/FC6.9 (1 pcs)</p> <p data-bbox="1027 779 1390 810">Tightening torque: 6.5 Nm ±10%</p> <p data-bbox="1027 815 1390 869">For robots with protection class IP30 (option 3350-300)</p>  <p data-bbox="1027 1182 1134 1202">xx1800002860</p> <p data-bbox="1027 1223 1390 1276">For robots with protection class IP54 (option 3350-540)</p> <p data-bbox="1027 1281 1390 1335">For robots with protection type Clean Room (option 3351-1)</p>  <p data-bbox="1027 1733 1134 1753">xx1900001642</p>

Continues on next page

Refitting the shaft for Clean Room/ IP54 robots

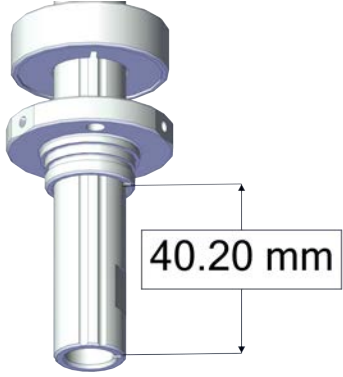
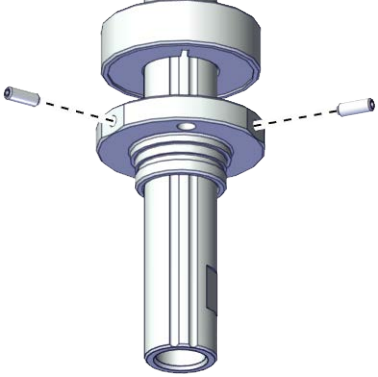
	Action	Note
1	<p>For robots with protection type Clean Room: Clean the joints that have been opened and wipe the parts free from particles with spirit on a lint free. See Cut the paint or surface on the robot before replacing parts on page 118</p> <p> Note</p> <p>After all repair work, wipe the Clean Room robot free from particles with spirit on a lint free cloth.</p>	
2	<p>For robots with protection class IP54 (option 3350-540)</p> <p>For robots with protection type Clean Room (option 3351-1)</p> <p>Install the shaft to the ball screw at 40.2 mm position to the lower of the ball screw.</p>	 <p>xx1900001617</p>
3	<p>For robots with protection class IP54 (option 3350-540)</p> <p>For robots with protection type Clean Room (option 3351-1)</p> <p>Secure the shaft to the ball screw with the screws.</p>	<p>Screws: Hexagon socket set screws with flat point, ISO 4026 stainless steel M3x8 (2 pcs)</p> <p>Tightening torque: 1.2 Nm ±10%</p>  <p>xx1900001616</p>

Continues on next page



5 Repair

5.6.1 Replacing the mechanical stopper

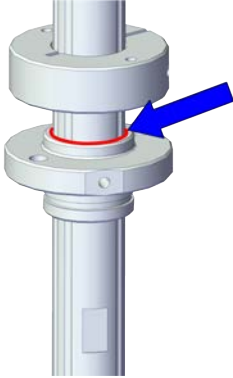
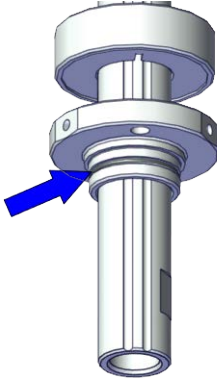
Continued

	Action	Note
4	<p>For robots with protection class IP54 (option 3350-540)</p> <p>Apply the glue to the upper contacted zone between the shaft and the ball screw.</p> <p> Note</p> <p>Fulfill the gaps on the ball screw in this contacted zone to make a sealing structure.</p>	 <p>xx1900001805</p>
5	<p>For robots with protection class IP54 (option 3350-540)</p> <p>For robots with protection type Clean Room (option 3351-1)</p> <p>Insert the O-ring to the shaft.</p>	 <p>xx1900001615</p>

Refitting the cover of the outer arm with the bellow

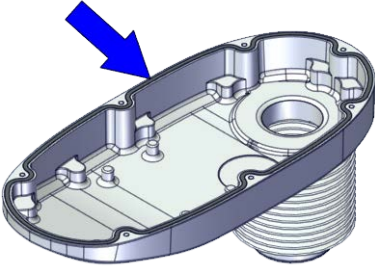
	Action	Note
1	<p>For robots with protection type Clean Room:</p> <p>Clean the joints that have been opened and wipe the parts free from particles with spirit on a lint free. See Cut the paint or surface on the robot before replacing parts on page 118</p> <p> Note</p> <p>After all repair work, wipe the Clean Room robot free from particles with spirit on a lint free cloth.</p>	
2	<p>For robots with protection class IP54 (option 3350-540)</p> <p>For robots with protection type Clean Room (option 3351-1)</p> <p>Check the gasket on the outer arm cover.</p> <p> Tip</p> <p>Replace the gasket if needed.</p>	 <p>xx1900001633</p>

Continues on next page

5.6.1 Replacing the mechanical stopper
Continued

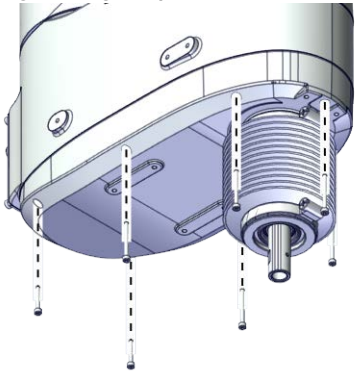
	Action	Note
3	<p>For robots with protection class IP54 (option 3350-540) For robots with protection type Clean Room (option 3351-1) Refit the cover with bellow and housing.</p>  Tip In this way, do not need to remove/ refit the bellow to the cover and the housing.	<p>For IRB 910INV-3/0.35: Screw: Hex socket head cap screw M3x20 12.9 Lafre 2C2B/FC6.9 (2 pcs) Hex socket head cap screw M3x30 12.9 Lafre 2C2B/FC6.9 (5 pcs) Tightening torque: 1.2 Nm ±10%</p> <p>For IRB 910INV-6/0.55: Screw: Hex socket head cap screw M3x20 12.9 Lafre 2C2B/FC6.9 (2 pcs)</p>
4	<p>Refit the screws.</p>	<p>Hex socket head cap screw M3x30 12.9 Lafre 2C2B/FC6.9 (7 pcs) Tightening torque: 1.2 Nm ±10%</p>  <p>xx1900001631</p>

Refitting the lower cover

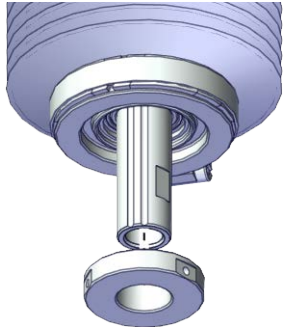
	Action	Note
1	<p>For robots with protection type Clean Room: Clean the joints that have been opened and wipe the parts free from particles with spirit on a lint free. See Cut the paint or surface on the robot before replacing parts on page 118</p>  Note After all repair work, wipe the Clean Room robot free from particles with spirit on a lint free cloth.	
2	<p>For robots with protection class IP54 (option 3350-540) For robots with protection type Clean Room (option 3351-1) Refit the lower cover to the ball screw.</p>	 <p>xx1900001607</p>

Continues on next page



5 Repair

5.6.1 Replacing the mechanical stopper

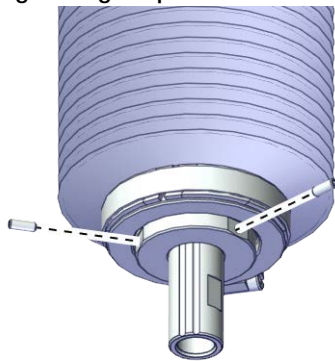
Continued

	Action	Note
3	<p>For robots with protection class IP54 (option 3350-540)</p> <p>For robots with protection type Clean Room (option 3351-1)</p> <p>Refit the locking screws.</p>	<p>Screws: Hexagon socket set screws with flat point, ISO 4026 stainless steel M3x8 (2 pcs)</p> <p>Tightening torque: 0.6 Nm \pm10%</p>  <p>xx1900001606</p>

Concluding procedure

	Action	Note
1	<p>For robots with protection type Clean Room:</p> <p>Seal and paint the joints that have been opened. See Cut the paint or surface on the robot before replacing parts on page 118</p> <p> Note</p> <p>After all repair work, wipe the Clean Room robot free from particles with spirit on a lint free cloth.</p>	
2	<p> DANGER</p> <p>Make sure all safety requirements are met when performing the first test run. See Test run after installation, maintenance, or repair on page 56.</p>	

5.6.2 Replacing the bellows

Location of the bellows

The bellows are located as shown in the figure.

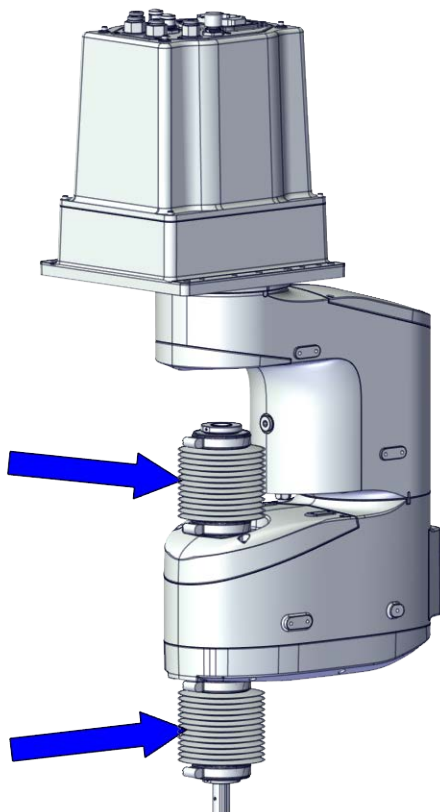

xx1900001546

Required spare parts



Note

The spare part numbers that are listed in the table can be out of date. See the latest spare parts of the IRB 910INV via myABB Business Portal, www.abb.com/myABB.

Spare part	Article number	Note
Bellow, 350 mm	3HAC062062-001	
Bellow, 550 mm	3HAC066917-001	
Bellow Gasket, 350 mm	3HAC071546-001	Replace if damaged.
Bellow Gasket, 550 mm	3HAC071547-001	Replace if damaged.
Cover, BS16, 350 mm	3HAC066654-001	Replace if damaged.
Cover, BS20, 550 mm	3HAC066915-001	Replace if damaged.
Cover Lower, BS16, 350 mm	3HAC067936-001	Replace if damaged.

Continues on next page

5 Repair

5.6.2 Replacing the bellows

Continued

Spare part	Article number	Note
Cover Lower, BS20, 550 mm	3HAC067937-001	Replace if damaged.
Extension shaft, BS16, 350 mm	3HAC073236-001	Replace if damaged.
Extension shaft, BS20, 550 mm	3HAC073239-001	Replace if damaged.
Shaft, BS16, 350 mm	3HAC066656-001	Replace if damaged.
Shaft, BS20, 550 mm	3HAC066916-001	Replace if damaged.
O-ring, 350 mm	3HAB3772-198	Replace if damaged.
O-ring, 550 mm	3HAC061327-023	Replace if damaged.
Housing, BS16, 350 mm	3HAC073237-001	Replace if damaged.
Housing, BS20, 550 mm	3HAC073240-001	Replace if damaged.
Housing Lower, BS16, 350 mm	3HAC073238-001	Replace if damaged.
Housing Lower, BS20, 550 mm	3HAC073241-001	Replace if damaged.

Required tools and equipment

Equipment	Article number	Note
Standard toolkit	-	Content is defined in section Standard toolkit on page 840 .
Calibration tool box, Axis Calibration	3HAC074119-001	Delivered as a set of calibration tools. Required if Axis Calibration is the valid calibration method for the robot. ⁱ
24 VDC power supply	-	Used to release the motor brakes.
Sonic tension meter	-	Used for measuring the timing belt tension.

ⁱ The robot is calibrated by either manual calibration or Axis Calibration at ABB factory before delivery. Always use the same calibration method as used at the factory.
Information about valid calibration method is found on the calibration label or in the calibration menu on the FlexPendant.
If no data is found related to standard calibration, manual calibration is used as default.

Required consumables

Consumable	Article number	Note
Cable straps	-	
Grease	-	THK AFA Used to lubricate the ball screw spline shaft.
Locking liquid	-	Loctite 2400 (or equivalent Loctite 243)
Sealing compound	3HAC026759-002	Sikaflex 521 FC For robots with protection type Clean Room.

Continues on next page

Deciding calibration routine

Decide which calibration routine to be used, based on the information in the table. Depending on which routine is chosen, action might be required prior to beginning the repair work of the robot, see the table.

	Action	Note
1	Decide which calibration routine to use for calibrating the robot. <ul style="list-style-type: none"> Reference calibration. External cable packages (DressPack) and tools can stay fitted on the robot. Fine calibration. All external cable packages (DressPack) and tools must be removed from the robot. 	
	If the robot is to be calibrated with reference calibration: Find previous reference values for the axis or create new reference values. These values are to be used after the repair procedure is completed, for calibration of the robot. If no previous reference values exist, and no new reference values can be created, then reference calibration is not possible.	Follow the instructions given in the reference calibration routine on the FlexPendant to create reference values. Creating new values requires possibility to move the robot. Read more about reference calibration for Axis Calibration in Reference calibration routine on page 798 .
	If the robot is to be calibrated with fine calibration: Remove all external cable packages (DressPack) and tools from the robot.	

Removing the upper bellow parts

Use these procedures to remove the upper bellow parts.

Preparations before removing the upper bellow parts



	Action	Note
1	Decide which calibration routine to use, and take actions accordingly prior to beginning the repair procedure.	

Continues on next page

5 Repair

5.6.2 Replacing the bellows

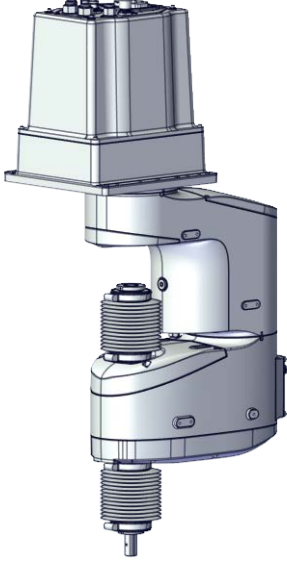

Continued

	Action	Note
2	Move the ball screw to lower position to have enough space for the repair procedure.	 <p>xx1900001627</p>
3	 <p>DANGER</p> <p>Turn off all:</p> <ul style="list-style-type: none"> • electric power supply • hydraulic pressure supply • air pressure supply <p>to the robot, before entering the safeguarded space.</p>	
4	 <p>CAUTION</p> <p>For robots with protection type Clean Room Always cut the paint with a knife and grind the paint edge when disassembling parts of the robot! See Cut the paint or surface on the robot before replacing parts on page 118.</p>	



Removing the upper cover

	Action	Note
1	 <p>DANGER</p> <p>Make sure that all supplies for electrical power, hydraulic pressure, and air pressure are turned off.</p>	

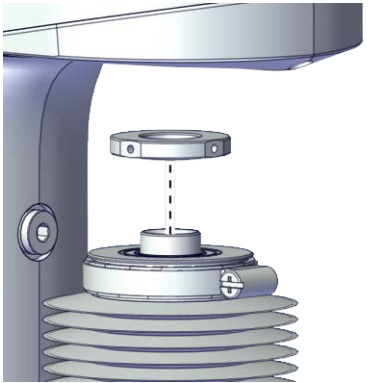
Continues on next page

	Action	Note
2	<p> CAUTION</p> <p>For robots with protection type Clean Room Always cut the paint with a knife and grind the paint edge when disassembling parts of the robot! See <i>Cut the paint or surface on the robot before replacing parts on page 118.</i></p>	
3	<p>For robots with protection class IP54 (option 3350-540) For robots with protection type Clean Room (option 3351-1) Loose the locking screws.</p>	 <p>xx1900001547</p>
4	<p>For robots with protection class IP54 (option 3350-540) For robots with protection type Clean Room (option 3351-1) Remove the upper cover from the ball screw.</p>	 <p>xx1900001548</p>

Removing the upper bellow



	Action	Note
1	<p> DANGER</p> <p>Make sure that all supplies for electrical power, hydraulic pressure, and air pressure are turned off.</p>	
2	<p> CAUTION</p> <p>For robots with protection type Clean Room Always cut the paint with a knife and grind the paint edge when disassembling parts of the robot! See <i>Cut the paint or surface on the robot before replacing parts on page 118.</i></p>	

Continues on next page

5 Repair

5.6.2 Replacing the bellows

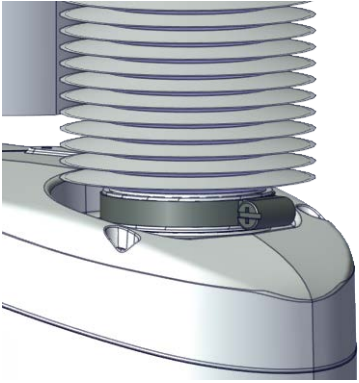

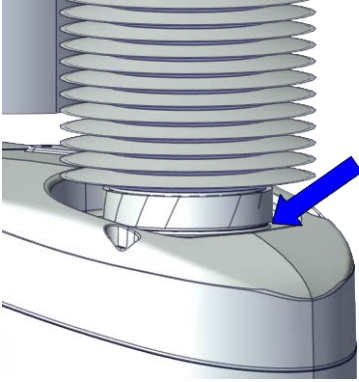
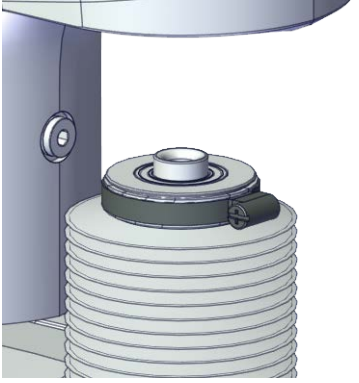
Continued

	Action	Note
3	<p>For robots with protection class IP54 (option 3350-540)</p> <p>For robots with protection type Clean Room (option 3351-1)</p> <p>Loosen the lower bellow clamp by loosening the screw and pull the clamp apart slightly.</p>	 <p>xx1900001549</p>
4	<p>For robots with protection class IP54 (option 3350-540)</p> <p>For robots with protection type Clean Room (option 3351-1)</p> <p>Remove the bellow from the outer arm casting cover.</p> <p> Note</p> <p>For robots with protection class IP54 (option 3350-540)</p> <p>Clean the outer arm casting cover from the glue if it will be reused.</p>	 <p>xx1900001551</p>
5	<p>For robots with protection class IP54 (option 3350-540)</p> <p>For robots with protection type Clean Room (option 3351-1)</p> <p>Loosen the upper bellow clamp by loosening the screw and pull the clamp apart slightly.</p>	 <p>xx1900001552</p>

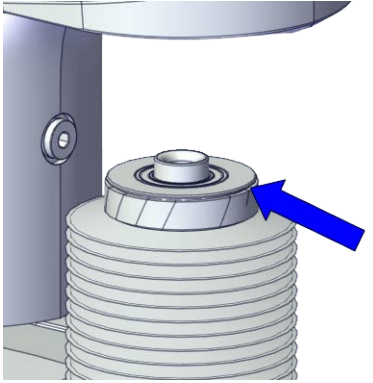
Continues on next page

	Action	Note
6	<p>For robots with protection class IP54 (option 3350-540) For robots with protection type Clean Room (option 3351-1) Remove the bellow from the upper housing carefully.</p> <p> Note</p> <p>For robots with protection class IP54 (option 3350-540) Clean the bellow from the glue if it will be reused.</p>	 <p>xx1900001554</p>
7	<p>For robots with protection class IP54 (option 3350-540) For robots with protection type Clean Room (option 3351-1) Release the bellow.</p>	

Removing the upper housing

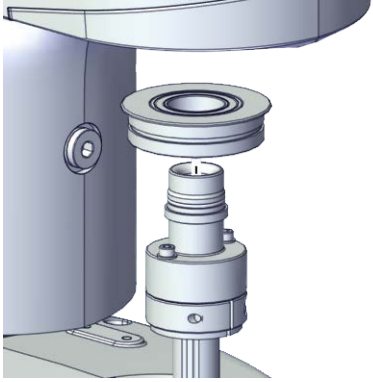

	Action	Note
1	<p> DANGER</p> <p>Make sure that all supplies for electrical power, hydraulic pressure, and air pressure are turned off.</p>	
2	<p> CAUTION</p> <p>For robots with protection type Clean Room Always cut the paint with a knife and grind the paint edge when disassembling parts of the robot! See Cut the paint or surface on the robot before replacing parts on page 118.</p>	
3	<p>For robots with protection class IP54 (option 3350-540) For robots with protection type Clean Room (option 3351-1) Remove the upper housing from the extension shaft.</p> <p> Note</p> <p>For robots with protection class IP54 (option 3350-540) Clean the upper housing from the glue if it will be reused.</p>	 <p>xx1900001555</p>

Continues on next page

5 Repair

5.6.2 Replacing the bellows

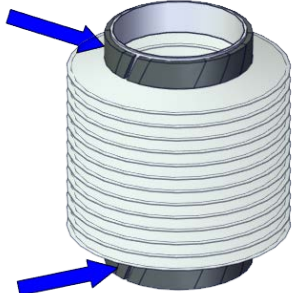

Continued

	Action	Note
4	<p>For robots with protection class IP54 (option 3350-540)</p> <p>For robots with protection type Clean Room (option 3351-1)</p> <p>Take out the released the bellow.</p> <p> Note</p> <p>For robots with protection class IP54 (option 3350-540)</p> <p>Clean the bellow from the glue if it will be reused.</p>	
5	<p>For robots with protection class IP54 (option 3350-540)</p> <p>Remove the bellow gaskets from the bellow.</p> <p> Note</p> <p>Clean the bellow gasket from the glue if it will be reused.</p> <p> Note</p> <p>Be careful when removing the bellow gaskets. If any broken, replace it.</p>	 <p>xx1900001803</p>







Refitting the upper bellow parts

Use these procedures to refit the upper bellow parts.

Refitting the bellow to the housing

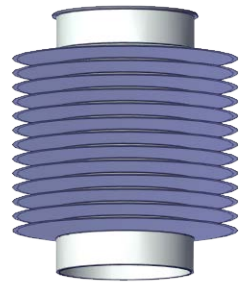
	Action	Note
1	<p>For robots with protection type Clean Room:</p> <p>Clean the joints that have been opened and wipe the parts free from particles with spirit on a lint free. See Cut the paint or surface on the robot before replacing parts on page 118</p> <p> Note</p> <p>After all repair work, wipe the Clean Room robot free from particles with spirit on a lint free cloth.</p>	
2	<p>For robots with protection class IP54 (option 3350-540)</p> <p>Apply the glue to the gap on the inner bellow gaskets.</p>	 <p>xx1900001804</p>

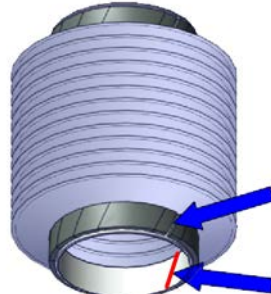
Continues on next page

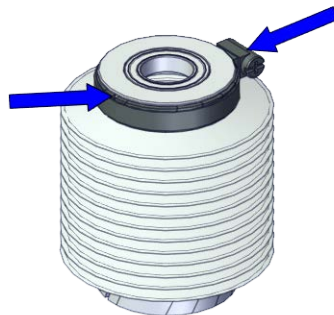
	Action	Note
3	<p>For robots with protection class IP54 (option 3350-540) Apply the glue to the corner of the upper housing.</p>	 <p>xx1900001559</p>
4	<p>For robots with protection class IP54 (option 3350-540) For robots with protection type Clean Room (option 3351-1) Install the bellow to the upper housing.</p> <p> Tip</p> <p>For robots with protection class IP54 (option 3350-540) Hold the bellow for a little while until it's attached to the housing.</p>	 <p>xx1900001560</p>
5	<p>For robots with protection class IP54 (option 3350-540) Install the bellow gaskets to the bellow</p> <p> Tip</p> <p>The angle between the gap on the bellow gasket and gap on the inner bellow gasket should be 90 degrees.</p>	 <p>xx1900001561</p>
6	<p>For robots with protection class IP54 (option 3350-540) For robots with protection type Clean Room (option 3351-1) Secure the bellow and the gasket with the clamp.</p> <p> Tip</p> <p>The opening part of the clamp should be in the opposite position to the gap on the bellow gasket.</p>	<p>Tightening torque: 0.6 Nm \pm10%</p>  <p>xx1900001563</p>

Continues on next page

5 Repair

5.6.2 Replacing the bellows

Continued

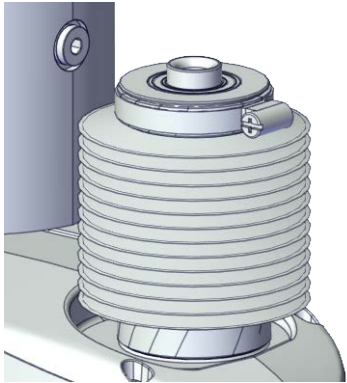

Refitting the bellow with the upper housing

	Action	Note
1	<p>For robots with protection type Clean Room: Clean the joints that have been opened and wipe the parts free from particles with spirit on a lint free. See Cut the paint or surface on the robot before replacing parts on page 118</p> <p> Note</p> <p>After all repair work, wipe the Clean Room robot free from particles with spirit on a lint free cloth.</p>	
2	<p>For robots with protection class IP54 (option 3350-540)</p> <p>For robots with protection type Clean Room (option 3351-1)</p> <p>Install the bellow with the upper housing to the extension shaft.</p>	 <p>xx1900001564</p>

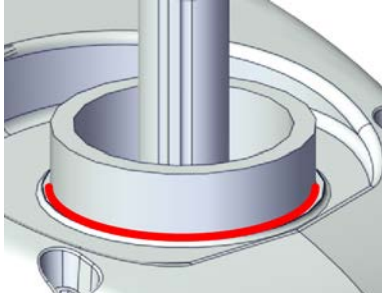
Refitting the upper bellow to outer arm

	Action	Note
1	<p>For robots with protection type Clean Room: Clean the joints that have been opened and wipe the parts free from particles with spirit on a lint free. See Cut the paint or surface on the robot before replacing parts on page 118</p> <p> Note</p> <p>After all repair work, wipe the Clean Room robot free from particles with spirit on a lint free cloth.</p>	
2	<p>For robots with protection class IP54 (option 3350-540)</p> <p>Apply the glue to the outer arm.</p>	 <p>xx1900001565</p>

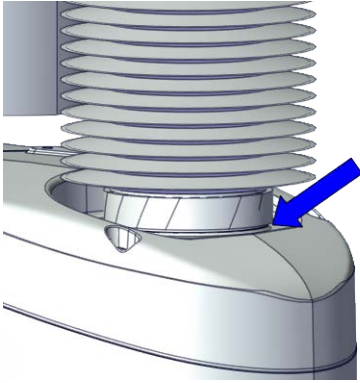
Continues on next page

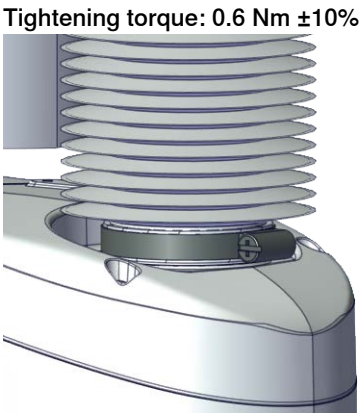
	Action	Note
3	<p>For robots with protection class IP54 (option 3350-540) For robots with protection type Clean Room (option 3351-1) Pull the lower end of the bellow to the outer arm.</p> <p> Tip</p> <p>For robots with protection class IP54 (option 3350-540) Hold the bellow for a little while until it's attached to the housing.</p>	 <p>xx1900001551</p>
4	<p>For robots with protection class IP54 (option 3350-540) For robots with protection type Clean Room (option 3351-1) Secure them with the clamp.</p> <p> Tip</p> <p>The opening part of the clamp should be in the opposite position to the gap on the bellow gasket.</p>	<p>Tightening torque: 0.6 Nm ±10%</p>  <p>xx1900001549</p>

Refitting the upper cover

	Action	Note
1	<p>For robots with protection type Clean Room: Clean the joints that have been opened and wipe the parts free from particles with spirit on a lint free. See Cut the paint or surface on the robot before replacing parts on page 118</p> <p> Note</p> <p>After all repair work, wipe the Clean Room robot free from particles with spirit on a lint free cloth.</p>	

Continues on next page



5 Repair

5.6.2 Replacing the bellows

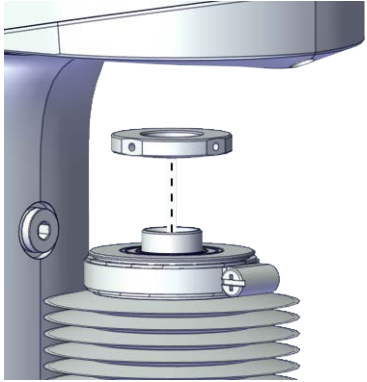
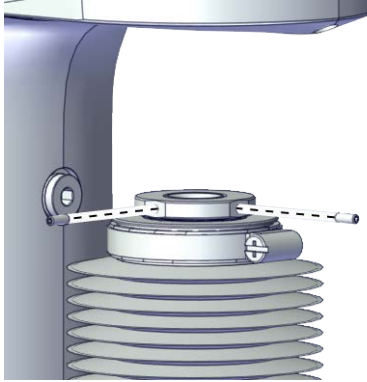
Continued

	Action	Note
2	<p>For robots with protection class IP54 (option 3350-540)</p> <p>For robots with protection type Clean Room (option 3351-1)</p> <p>Refit the upper cover to the ball screw.</p>	 <p>xx1900001548</p>
3	<p>For robots with protection class IP54 (option 3350-540)</p> <p>For robots with protection type Clean Room (option 3351-1)</p> <p>Refit the locking screws.</p>	<p>Screws: Hexagon socket set screws with flat point, ISO 4026 stainless steel M3x8 (2 pcs)</p> <p>Tightening torque: 0.6 Nm \pm10%</p>  <p>xx1900001547</p>

Concluding procedure



	Action	Note
1	<p>For robots with protection type Clean Room:</p> <p>Seal and paint the joints that have been opened. See Cut the paint or surface on the robot before replacing parts on page 118</p> <p> Note</p> <p>After all repair work, wipe the Clean Room robot free from particles with spirit on a lint free cloth.</p>	
2	<p> DANGER</p> <p>Make sure all safety requirements are met when performing the first test run. See Test run after installation, maintenance, or repair on page 56.</p>	

Continues on next page

Removing the lower bellow parts

Use these procedures to remove the lower bellow parts.

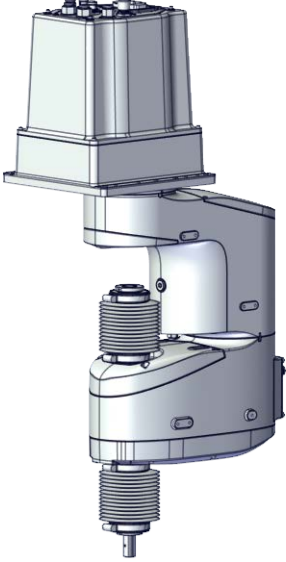
Preparations before removing the lower bellow parts

	Action	Note
1	Decide which calibration routine to use, and take actions accordingly prior to beginning the repair procedure.	
2	Move the ball screw to lower position to have enough space for the repair procedure.	 <p>xx1900001627</p>
3	<p> DANGER</p> <p>Turn off all:</p> <ul style="list-style-type: none"> • electric power supply • hydraulic pressure supply • air pressure supply <p>to the robot, before entering the safeguarded space.</p>	
4	<p> CAUTION</p> <p>For robots with protection type Clean Room Always cut the paint with a knife and grind the paint edge when disassembling parts of the robot! See <i>Cut the paint or surface on the robot before replacing parts on page 118.</i></p>	



Continues on next page

5 Repair

5.6.2 Replacing the bellows

Continued

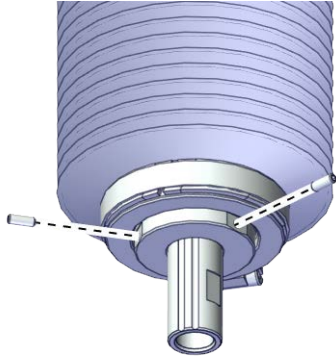
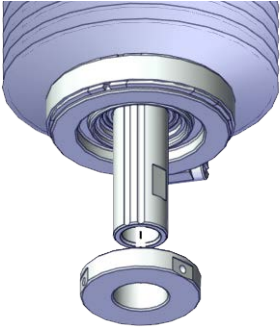

Removing the lower cover

	Action	Note
1	 DANGER Make sure that all supplies for electrical power, hydraulic pressure, and air pressure are turned off.	
2	 CAUTION For robots with protection type Clean Room Always cut the paint with a knife and grind the paint edge when disassembling parts of the robot! See Cut the paint or surface on the robot before replacing parts on page 118 .	
3	For robots with protection class IP54 (option 3350-540) For robots with protection type Clean Room (option 3351-1) Loose the locking screws.	 <small>xx1900001606</small>
4	For robots with protection class IP54 (option 3350-540) For robots with protection type Clean Room (option 3351-1) Remove the lower cover from the ball screw.	 <small>xx1900001607</small>

Removing the lower bellow

	Action	Note
1	 DANGER Make sure that all supplies for electrical power, hydraulic pressure, and air pressure are turned off.	

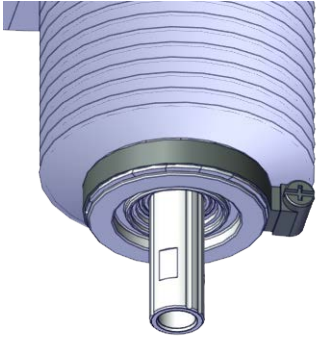
Continues on next page

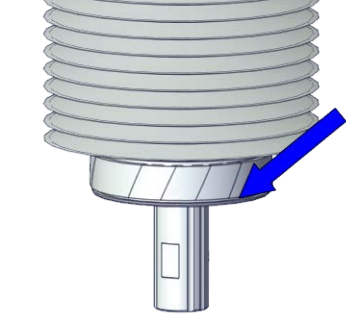
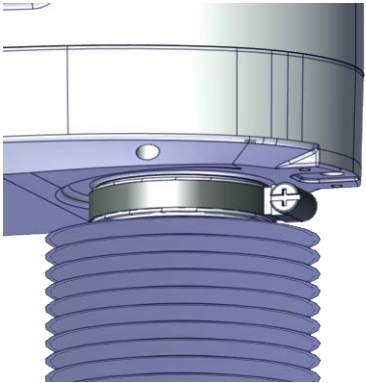
	Action	Note
2	<p> CAUTION</p> <p>For robots with protection type Clean Room Always cut the paint with a knife and grind the paint edge when disassembling parts of the robot! See Cut the paint or surface on the robot before replacing parts on page 118.</p>	
3	<p>For robots with protection class IP54 (option 3350-540)</p> <p>For robots with protection type Clean Room (option 3351-1)</p> <p>Loosen the lower bellow clamp by loosening the screw and pull the clamp apart slightly.</p>	 <p>xx1900001608</p>
4	<p>For robots with protection class IP54 (option 3350-540)</p> <p>For robots with protection type Clean Room (option 3351-1)</p> <p>Remove the bellow from the lower housing carefully.</p> <p> Note</p> <p>For robots with protection class IP54 (option 3350-540)</p> <p>Clean the bellow from the glue if it will be reused.</p>	 <p>xx1900001610</p>
5	<p>For robots with protection class IP54 (option 3350-540)</p> <p>For robots with protection type Clean Room (option 3351-1)</p> <p>Loosen the upper bellow clamp by loosening the screw and pull the clamp apart slightly.</p>	 <p>xx1900001611</p>

Continues on next page



5 Repair

5.6.2 Replacing the bellows

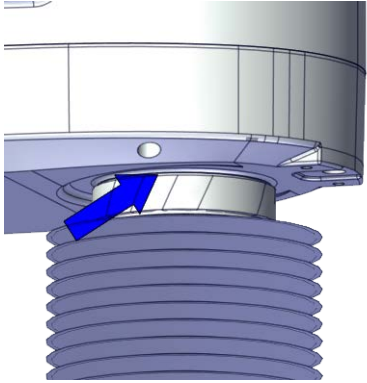

Continued

	Action	Note
6	<p>For robots with protection class IP54 (option 3350-540)</p> <p>For robots with protection type Clean Room (option 3351-1)</p> <p>Remove the bellow from the outer arm cover.</p> <p> Note</p> <p>For robots with protection class IP54 (option 3350-540)</p> <p>Clean the outer arm cover from the glue if it will be reused.</p>	 <p>xx1900001613</p>
7	<p>For robots with protection class IP54 (option 3350-540)</p> <p>For robots with protection type Clean Room (option 3351-1)</p> <p>Release the bellow.</p>	

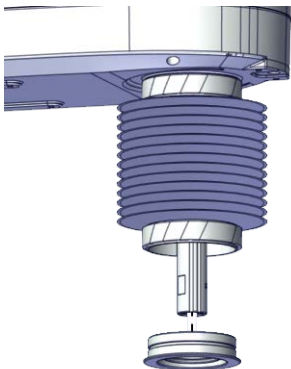
Removing the lower housing

	Action	Note
1	<p> DANGER</p> <p>Make sure that all supplies for electrical power, hydraulic pressure, and air pressure are turned off.</p>	
2	<p> CAUTION</p> <p>For robots with protection type Clean Room</p> <p>Always cut the paint with a knife and grind the paint edge when disassembling parts of the robot! See Cut the paint or surface on the robot before replacing parts on page 118.</p>	
3	<p>For robots with protection class IP54 (option 3350-540)</p> <p>For robots with protection type Clean Room (option 3351-1)</p> <p>Remove the lower housing from the shaft.</p> <p> Note</p> <p>For robots with protection class IP54 (option 3350-540)</p> <p>Clean the lower housing from the glue if it will be reused.</p>	 <p>xx1900001614</p>

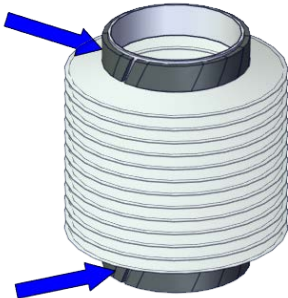

Continues on next page

	Action	Note
4	<p>For robots with protection class IP54 (option 3350-540) For robots with protection type Clean Room (option 3351-1) Take out the released the bellow.</p> <p> Note</p> <p>For robots with protection class IP54 (option 3350-540) Clean the bellow from the glue if it will be reused.</p>	
5	<p>For robots with protection class IP54 (option 3350-540) Remove the bellow gaskets from the bellow.</p> <p> Note</p> <p>Clean the bellow gasket from the glue if it will be reused.</p> <p> Note</p> <p>Be careful when removing the bellow gaskets. If any broken, replace it.</p>	 <p>xx1900001803</p>

Refitting the lower bellow parts

Use these procedures to refit the lower bellow parts.

Refitting the bellow to the housing







	Action	Note
1	<p>For robots with protection type Clean Room: Clean the joints that have been opened and wipe the parts free from particles with spirit on a lint free. See Cut the paint or surface on the robot before replacing parts on page 118</p> <p> Note</p> <p>After all repair work, wipe the Clean Room robot free from particles with spirit on a lint free cloth.</p>	
2	<p>For robots with protection class IP54 (option 3350-540) Apply the glue to the gap on the inner bellow gaskets.</p>	 <p>xx1900001804</p>

Continues on next page

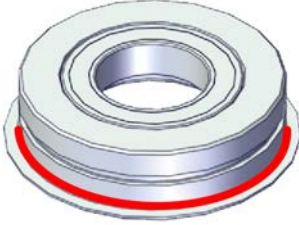
5 Repair

5.6.2 Replacing the bellows

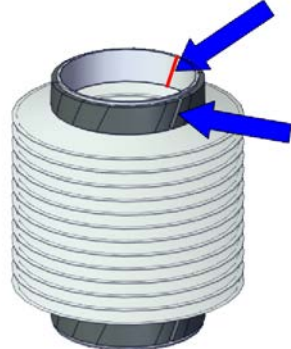
Continued

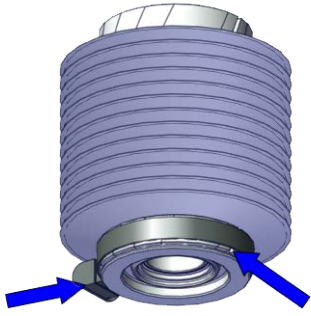
	Action	Note
3	<p>For robots with protection class IP54 (option 3350-540)</p> <p>Apply the glue to the corner of the lower housing.</p>	 <p>xx1900001618</p>
4	<p>For robots with protection class IP54 (option 3350-540)</p> <p>For robots with protection type Clean Room (option 3351-1)</p> <p>Install the bellow to the lower housing.</p> <p> Tip</p> <p>For robots with protection class IP54 (option 3350-540)</p> <p>Hold the bellow for a little while until it's attached to the housing.</p>	 <p>xx1900001619</p>
5	<p>For robots with protection class IP54 (option 3350-540)</p> <p>Install the bellow gaskets to the bellow.</p> <p> Tip</p> <p>The angle between the gap on the bellow gasket and gap on the inner bellow gasket should be 90 degrees.</p>	 <p>xx1900001620</p>
6	<p>For robots with protection class IP54 (option 3350-540)</p> <p>For robots with protection type Clean Room (option 3351-1)</p> <p>Secure them with the clamp.</p> <p> Tip</p> <p>The opening part of the clamp should be in the opposite position to the gap on the bellow gasket.</p>	<p>Tightening torque: 0.6 Nm \pm10%</p>  <p>xx1900001622</p>

Continues on next page

Refitting the bellow with the lower housing

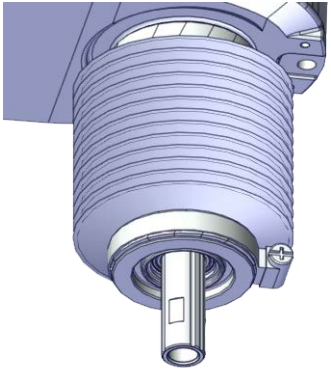
	Action	Note
1	<p>For robots with protection type Clean Room: Clean the joints that have been opened and wipe the parts free from particles with spirit on a lint free. See Cut the paint or surface on the robot before replacing parts on page 118</p> <p> Note</p> <p>After all repair work, wipe the Clean Room robot free from particles with spirit on a lint free cloth.</p>	
2	<p>For robots with protection class IP54 (option 3350-540) For robots with protection type Clean Room (option 3351-1) Install the bellow with the lower housing to the shaft.</p>	 <p>xx1900001623</p>

Refitting the lower cover

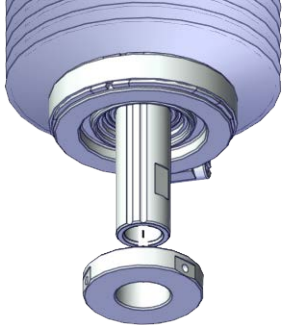
	Action	Note
1	<p>For robots with protection type Clean Room: Clean the joints that have been opened and wipe the parts free from particles with spirit on a lint free. See Cut the paint or surface on the robot before replacing parts on page 118</p> <p> Note</p> <p>After all repair work, wipe the Clean Room robot free from particles with spirit on a lint free cloth.</p>	
2	<p>For robots with protection class IP54 (option 3350-540) For robots with protection type Clean Room (option 3351-1) Refit the lower cover to the ball screw.</p>	 <p>xx1900001607</p>

Continues on next page

5 Repair

5.6.2 Replacing the bellows

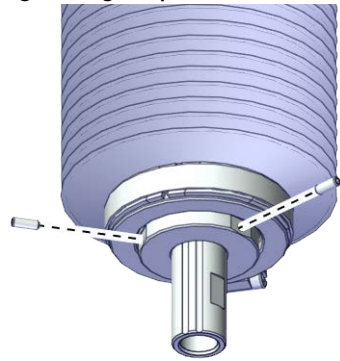

Continued

	Action	Note
3	<p>For robots with protection class IP54 (option 3350-540)</p> <p>For robots with protection type Clean Room (option 3351-1)</p> <p>Refit the locking screws.</p>	<p>Screws: Hexagon socket set screws with flat point, ISO 4026 stainless steel M3x8 (2 pcs)</p> <p>Tightening torque: 0.6 Nm \pm10%</p>  <p>xx1900001606</p>

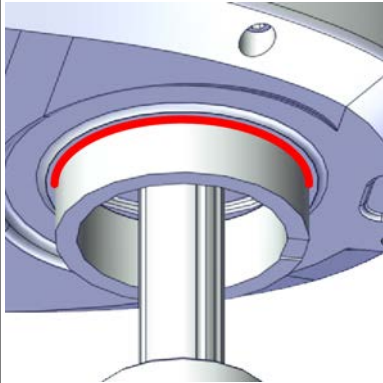
Refitting the lower bellow to outer arm

	Action	Note
1	<p>For robots with protection type Clean Room:</p> <p>Clean the joints that have been opened and wipe the parts free from particles with spirit on a lint free. See Cut the paint or surface on the robot before replacing parts on page 118</p> <p> Note</p> <p>After all repair work, wipe the Clean Room robot free from particles with spirit on a lint free cloth.</p>	
2	<p>For robots with protection class IP54 (option 3350-540)</p> <p>Apply the glue to the outer arm.</p>	 <p>xx1900001624</p>

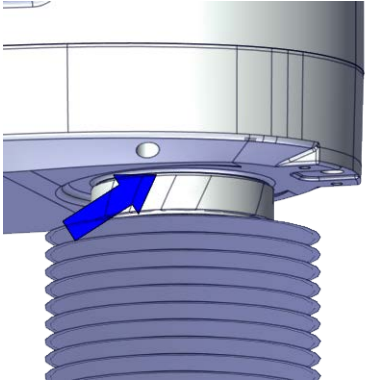
Continues on next page

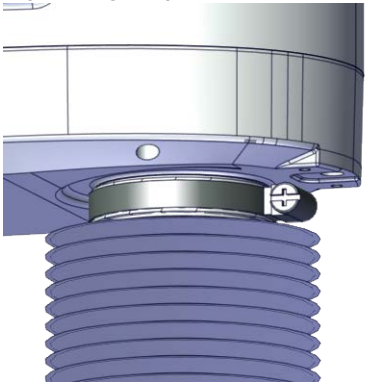
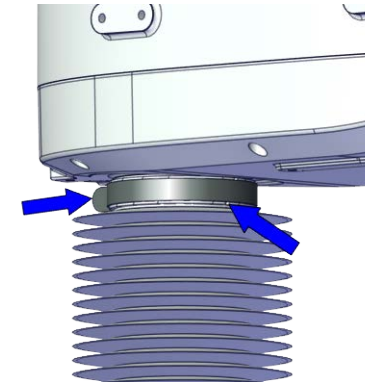
	Action	Note
3	<p>For robots with protection class IP54 (option 3350-540) For robots with protection type Clean Room (option 3351-1) Pull the upper end of the bellow to the outer arm.</p> <p> Tip</p> <p>For robots with protection class IP54 (option 3350-540) Hold the bellow for a little while until it's attached to the housing.</p>	 <p>xx1900001613</p>
4	<p>For robots with protection class IP54 (option 3350-540) For robots with protection type Clean Room (option 3351-1) Secure them with the clamp.</p> <p> Tip</p> <p>The opening part of the clamp should be in the opposite position to the gap on the bellow gasket.</p>	<p>Tightening torque: 0.6 Nm ±10%</p>  <p>xx1900001611</p>  <p>xx1900001625</p>

Concluding procedure

	Action	Note
1	<p>For robots with protection type Clean Room: Seal and paint the joints that have been opened. See Cut the paint or surface on the robot before replacing parts on page 118</p> <p> Note</p> <p>After all repair work, wipe the Clean Room robot free from particles with spirit on a lint free cloth.</p>	

Continues on next page

5 Repair

5.6.2 Replacing the bellows

Continued

	Action	Note
2	 DANGER Make sure all safety requirements are met when performing the first test run. See Test run after installation, maintenance, or repair on page 56 .	

5.6.3 Replacing the pulley on the ball screw upper position

Location of the pulley

The pulley is located as shown in the figure.

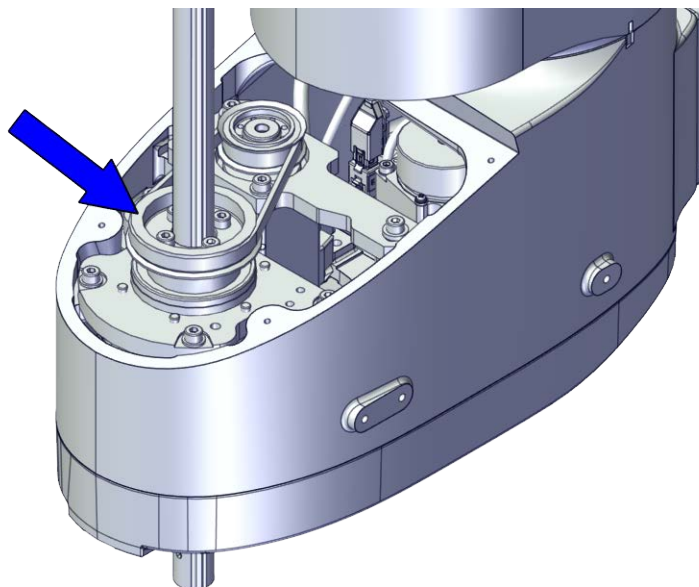

xx1800002863

Required spare parts



Note

The spare part numbers that are listed in the table can be out of date. See the latest spare parts of the IRB 910INV via myABB Business Portal, www.abb.com/myABB.

Spare part	Article number	Note
Pulley Z2/3, 350mm	3HAC061857-001	
Pulley Z2/3, 550mm	3HAC063637-001	
Mechanical-Stop top, D16	3HAC073060-001	Used for IRB 910INV-3/0.35
Mechanical-Stop top, D20	3HAC073068-001	Used for IRB 910INV-6/0.55
Timing belt	3HAC061862-001	
Outer arm cover casting, 350 mm	3HAC073059-001	
Outer arm cover casting, 550 mm	3HAC073067-001	
Outer arm cover casting, 350 mm, Clean Room	3HAC073231-001	Used with protection type Clean Room.
Outer arm cover casting, 550 mm, Clean Room	3HAC073235-001	Used with protection type Clean Room.
Gasket, casting cover, 350 mm	3HAC061870-001	Replace if damaged.
Gasket, casting cover, 550 mm	3HAC061871-001	Replace if damaged.

Continues on next page

5 Repair

5.6.3 Replacing the pulley on the ball screw upper position

Continued

Required tools and equipment

Equipment	Article number	Note
Standard toolkit	-	Content is defined in section Standard toolkit on page 840 .
Calibration tool box, Axis Calibration	3HAC074119-001	Delivered as a set of calibration tools. Required if Axis Calibration is the valid calibration method for the robot. ⁱ
24 VDC power supply	-	Used to release the motor brakes.
Sonic tension meter	-	Used for measuring the timing belt tension.

ⁱ The robot is calibrated by either manual calibration or Axis Calibration at ABB factory before delivery. Always use the same calibration method as used at the factory.
Information about valid calibration method is found on the calibration label or in the calibration menu on the FlexPendant.
If no data is found related to standard calibration, manual calibration is used as default.

Required consumables

Consumable	Article number	Note
Cable straps	-	
Grease	-	THK AFA Used to lubricate the ball screw spline shaft.

Deciding calibration routine

Decide which calibration routine to be used, based on the information in the table. Depending on which routine is chosen, action might be required prior to beginning the repair work of the robot, see the table.

	Action	Note
1	Decide which calibration routine to use for calibrating the robot. <ul style="list-style-type: none">Reference calibration. External cable packages (DressPack) and tools can stay fitted on the robot.Fine calibration. All external cable packages (DressPack) and tools must be removed from the robot.	
	If the robot is to be calibrated with reference calibration: Find previous reference values for the axis or create new reference values. These values are to be used after the repair procedure is completed, for calibration of the robot. If no previous reference values exist, and no new reference values can be created, then reference calibration is not possible.	Follow the instructions given in the reference calibration routine on the FlexPendant to create reference values. Creating new values requires possibility to move the robot. Read more about reference calibration for Axis Calibration in Reference calibration routine on page 798 .

Continues on next page

5.6.3 Replacing the pulley on the ball screw upper position



Continued

Action	Note
<p>If the robot is to be calibrated with fine calibration:</p> <p>Remove all external cable packages (DressPack) and tools from the robot.</p>	

Removing the pulley on the ball screw upper position

Use these procedures to remove the pulley.

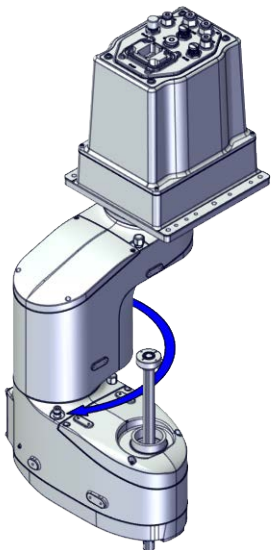
Preparations before removing the pulley

Action	Note
1	Decide which calibration routine to use, and take actions accordingly prior to beginning the repair procedure.
2	<p>If there is no enough space for the maintenance work, remove the robot from the wall and place it on the maintenance bracket.</p> <p> CAUTION</p> <p>Do not lay down the robot during the transportation, always keep it straight.</p> <p>If the robot lay down in any situation, the grease may come out from gearbox.</p>
3	<p>Jog the outer arm to access the casting cover screws.</p>  <p>xx1800003407</p>
4	<p> DANGER</p> <p>Turn off all:</p> <ul style="list-style-type: none"> • electric power supply • hydraulic pressure supply • air pressure supply <p>to the robot, before entering the safeguarded space.</p>

Continues on next page



5 Repair

5.6.3 Replacing the pulley on the ball screw upper position

Continued

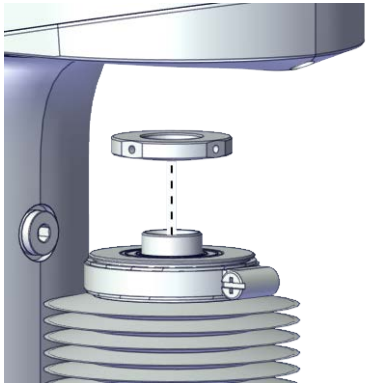

	Action	Note
5	 CAUTION For robots with protection type Clean Room Always cut the paint with a knife and grind the paint edge when disassembling parts of the robot! See Cut the paint or surface on the robot before replacing parts on page 118 .	

Removing the upper cover

	Action	Note
1	 DANGER Make sure that all supplies for electrical power, hydraulic pressure, and air pressure are turned off.	
2	 CAUTION For robots with protection type Clean Room Always cut the paint with a knife and grind the paint edge when disassembling parts of the robot! See Cut the paint or surface on the robot before replacing parts on page 118 .	
3	For robots with protection class IP54 (option 3350-540) For robots with protection type Clean Room (option 3351-1) Loose the locking screws.	 <small>xx1900001547</small>
4	For robots with protection class IP54 (option 3350-540) For robots with protection type Clean Room (option 3351-1) Remove the upper cover from the ball screw.	 <small>xx1900001548</small>

Continues on next page

Removing the casting cover of the outer arm





	Action	Note
1	 DANGER Make sure that all supplies for electrical power, hydraulic pressure, and air pressure are turned off.	
2	 CAUTION For robots with protection type Clean Room Always cut the paint with a knife and grind the paint edge when disassembling parts of the robot! See <i>Cut the paint or surface on the robot before replacing parts on page 118.</i>	

Continues on next page

5 Repair

5.6.3 Replacing the pulley on the ball screw upper position

Continued

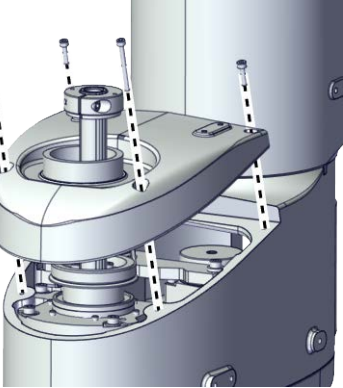
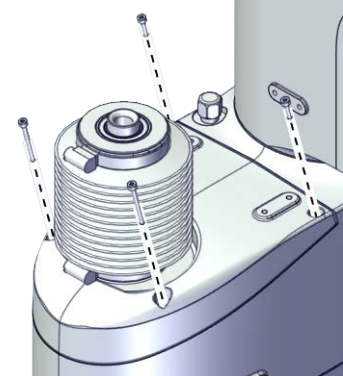
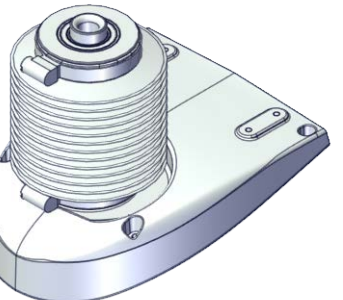
	Action	Note
3	<p>Remove the screws on the casting cover of the outer arm and remove the cover.</p> <p> Note</p> <p>For robots with protection class IP54 (option 3350-540) For robots with protection type Clean Room (option 3351-1) Remove the cover with bellow and housing.</p> <p> Note</p> <p>The bellow does not need to be removed separately.</p> <p> CAUTION</p> <p>There is a gasket in the cover. Be careful when removing the cover with bellow and housing.</p> <p> Tip</p> <p>Check the gasket and replace it if needed.</p>	<p>For robots with protection class IP30 (option 3350-300)</p>  <p>xx1800002883</p> <p>For robots with protection class IP54 (option 3350-540) For robots with protection type Clean Room (option 3351-1)</p>  <p>xx1900001628</p>  <p>xx1900001629</p>



Removing the axis-3 timing belt

	Action	Note
1	<p> DANGER</p> <p>Make sure that all supplies for electrical power, hydraulic pressure, and air pressure are turned off.</p>	

Continues on next page

5.6.3 Replacing the pulley on the ball screw upper position

Continued

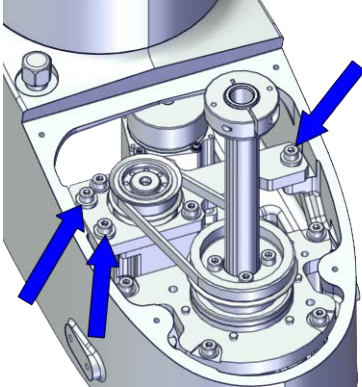
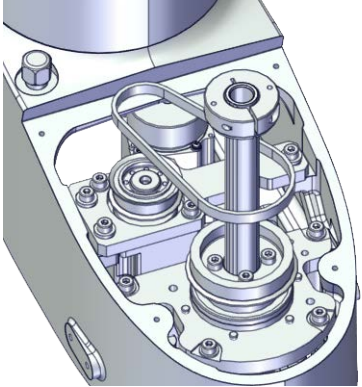
	Action	Note
2	<p> CAUTION</p> <p>For robots with protection type Clean Room Always cut the paint with a knife and grind the paint edge when disassembling parts of the robot! See <i>Cut the paint or surface on the robot before replacing parts on page 118.</i></p>	
3	<p> DANGER</p> <p>Make sure that the ball screw is supported with something. The sudden drop of the ball screw due the lost of the axis-3 motor may cause danger.</p>	
4	<p>Loosen the screws of the axis-3 motor sub-assembly to let the axis-3 timing belt free.</p>	 <p>xx1800003391</p>
5	<p>Remove the timing belt.</p>	 <p>xx1800003392</p>

Removing the extension shaft for Clean Room/ IP54 robots

	Action	Note
1	<p> DANGER</p> <p>Make sure that all supplies for electrical power, hydraulic pressure, and air pressure are turned off.</p>	

Continues on next page

5 Repair

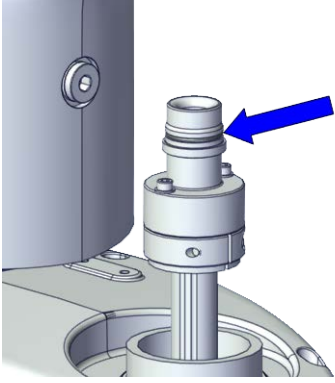
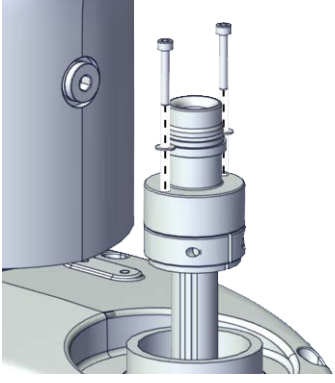
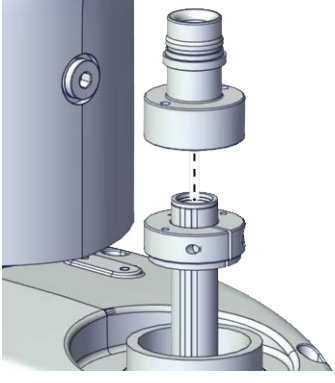

5.6.3 Replacing the pulley on the ball screw upper position

Continued

	Action	Note
2	<p> CAUTION</p> <p>For robots with protection type Clean Room Always cut the paint with a knife and grind the paint edge when disassembling parts of the robot! See <i>Cut the paint or surface on the robot before replacing parts on page 118.</i></p>	
3	<p>For robots with protection class IP54 (option 3350-540) For robots with protection type Clean Room (option 3351-1) Remove the O-ring from the upper housing.</p>	 <p>xx1900001556</p>
4	<p>For robots with protection class IP54 (option 3350-540) For robots with protection type Clean Room (option 3351-1) Loose the attachment screws.</p>	 <p>xx1900001557</p>
5	<p>For robots with protection class IP54 (option 3350-540) For robots with protection type Clean Room (option 3351-1) Remove the extension shaft from the mechanical stopper.</p>	 <p>xx1900001558</p>

Continues on next page

Removing the upper mechanical stopper

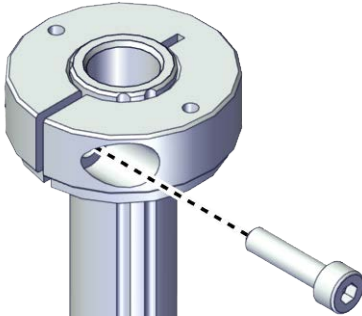
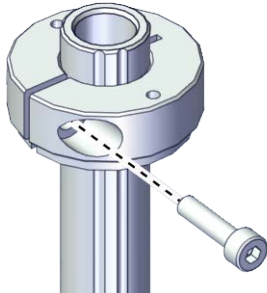

	Action	Note
1	 <p>DANGER</p> <p>Make sure that all supplies for electrical power, hydraulic pressure, and air pressure are turned off.</p>	
2	 <p>CAUTION</p> <p>For robots with protection type Clean Room Always cut the paint with a knife and grind the paint edge when disassembling parts of the robot! See Cut the paint or surface on the robot before replacing parts on page 118.</p>	
3	Remove the screw.	<p>For robots with protection class IP30 (option 3350-300)</p>  <p>xx1800002858</p> <p>For robots with protection class IP54 (option 3350-540) For robots with protection type Clean Room (option 3351-1)</p>  <p>xx1900001640</p>

Continues on next page



5 Repair

5.6.3 Replacing the pulley on the ball screw upper position

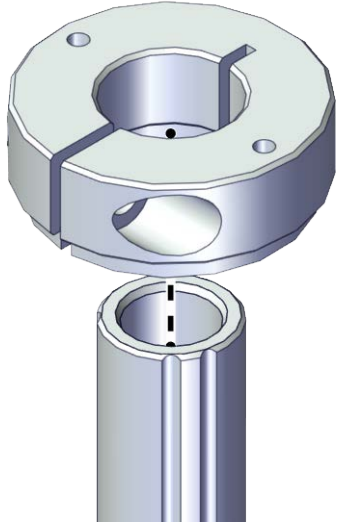
Continued

	Action	Note
4	<p>Remove the mechanical stopper.</p> <p> Tip</p> <p>Hold the ball screw to prevent it from dropping. Or the ball screw may be destroyed.</p> <p> CAUTION</p> <p>If the ball screw nut or ball screw spline nut go out of the screw shaft, the ball screw is destroyed. Be careful when you do any work that may cause this.</p>	 <p>xx1800002859</p>



Removing the pulley on the ball screw upper position

	Action	Note
1	<p> DANGER</p> <p>Make sure that all supplies for electrical power, hydraulic pressure, and air pressure are turned off.</p>	
2	<p> ELECTROSTATIC DISCHARGE (ESD)</p> <p>The unit is sensitive to ESD. Before handling the unit read the safety information in section The unit is sensitive to ESD on page 45.</p>	
3	<p> CAUTION</p> <p>For robots with protection type Clean Room</p> <p>Always cut the paint with a knife and grind the paint edge when disassembling parts of the robot! See Cut the paint or surface on the robot before replacing parts on page 118.</p>	

Continues on next page

5.6.3 Replacing the pulley on the ball screw upper position

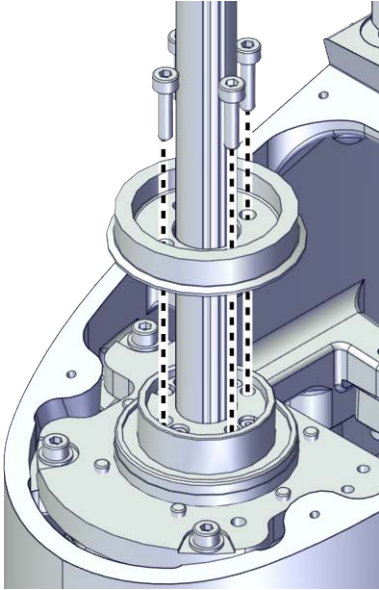

Continued

	Action	Note
4	Remove the screws.	 <p data-bbox="1061 907 1173 929">xx1800002862</p>
5	<p data-bbox="513 353 829 387">Remove the pulley carefully.</p> <p data-bbox="513 409 638 481">  Tip Hold the ball screw to prevent it from dropping. Or the ball screw may be destroyed. </p> <p data-bbox="513 571 718 627">  CAUTION If the ball screw nut or ball screw spline nut go out of the screw shaft, the ball screw is destroyed. Be careful when you do any work that may cause this. </p>	

Refitting the pulley on the ball screw upper position

Use these procedures to refit the pulley.

Refitting the pulley on the ball screw upper position





	Action	Note
1	<p data-bbox="513 1193 1037 1265">  ELECTROSTATIC DISCHARGE (ESD) The unit is sensitive to ESD. Before handling the unit read the safety information in section The unit is sensitive to ESD on page 45. </p>	
2	<p data-bbox="513 1400 1045 1545"> For robots with protection type Clean Room: Clean the joints that have been opened and wipe the parts free from particles with spirit on a lint free. See Cut the paint or surface on the robot before replacing parts on page 118 </p> <p data-bbox="513 1556 1045 1691">  Note After all repair work, wipe the Clean Room robot free from particles with spirit on a lint free cloth. </p>	

Continues on next page

5 Repair

5.6.3 Replacing the pulley on the ball screw upper position

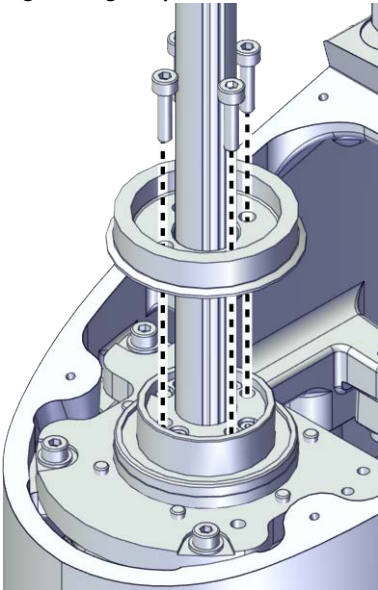
Continued

	Action	Note
3	<p>Refit the pulley to the ball screw carefully.</p> <p> Tip</p> <p>Hold the ball screw to prevent it from dropping. Or the ball screw may be destroyed.</p> <p> CAUTION</p> <p>If the ball screw nut or ball screw spline nut go out of the screw shaft, the ball screw is destroyed. Be careful when you do any work that may cause this.</p>	<p>For IRB 910INV-3/0.35: Screws: Hex socket head cap screw M4x16 12.9 Lafre 2C2B/FC6.9 (4 pcs) Tightening torque: 2 Nm \pm10%</p> <p>For IRB 910INV-6/0.55: Screws: Hex socket head cap screw M5x25 12.9 Lafre 2C2B/FC6.9 (4 pcs) Tightening torque: 5 Nm \pm10%</p>  <p>xx1800002862</p>
4	<p>Refit the screws.</p> <p> Tip</p> <p>Secure with the special stopping tool to prevent the pulley from rotating.</p>	



Refitting the upper mechanical stopper

	Action	Note
1	<p>For robots with protection type Clean Room: Clean the joints that have been opened and wipe the parts free from particles with spirit on a lint free. See Cut the paint or surface on the robot before replacing parts on page 118</p> <p> Note</p> <p>After all repair work, wipe the Clean Room robot free from particles with spirit on a lint free cloth.</p>	

Continues on next page

5.6.3 Replacing the pulley on the ball screw upper position

Continued

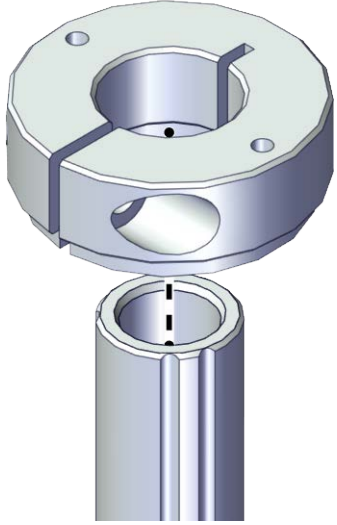
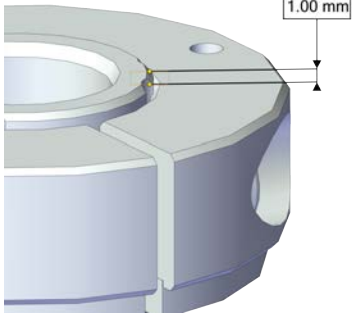
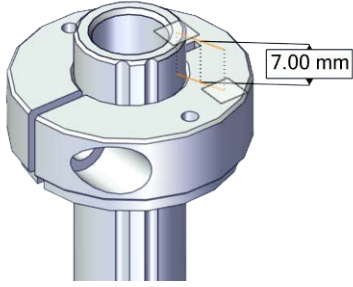
	Action	Note
2	<p>Refit the mechanical stopper to the ball screw at 1 mm position to the upper of the ball screw.</p> <p> Note</p> <p>For robots with protection class IP54 (option 3350-540) For robots with protection type Clean Room (option 3351-1) For IRB 910INV-3/0.35, refit the mechanical stopper to the ball screw at 7 mm position to the upper of the ball screw. For IRB 910INV-6/0.55, refit the mechanical stopper to the ball screw at 2 mm position to the upper of the ball screw.</p> <p> Tip</p> <p>Hold the ball screw to prevent it from dropping. Or the ball screw may be destroyed.</p> <p> CAUTION</p> <p>If the ball screw nut or ball screw spline nut go out of the screw shaft, the ball screw is destroyed. Be careful when you do any work that may cause this.</p>	 <p>xx1800002859</p> <p>For robots with protection class IP30 (option 3350-300)</p>  <p>xx1900002012</p> <p>For robots with protection class IP54 (option 3350-540) For robots with protection type Clean Room (option 3351-1) For IRB 910INV-3/0.35</p>  <p>xx1900001639</p> <p>For IRB 910INV-6/0.55</p>

Continues on next page

5 Repair

5.6.3 Replacing the pulley on the ball screw upper position

Continued

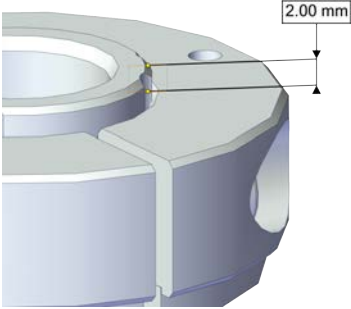
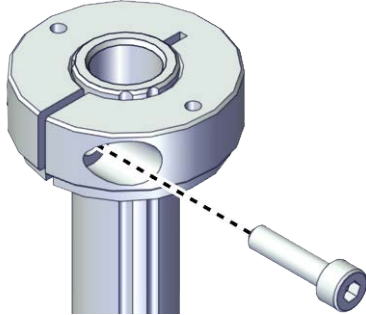
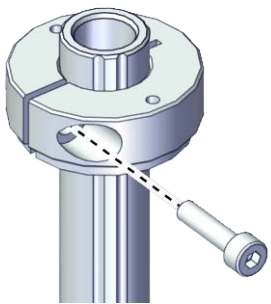
	Action	Note
		 <p data-bbox="1029 667 1141 689">xx1900002011</p>
3	Refit the screw.	<p data-bbox="1029 723 1396 902">Screws: Hex socket head cap screw M4x16 12.9 Lafre 2C2B/FC6.9 (1 pcs) Tightening torque: 6.5 Nm \pm10% For robots with protection class IP30 (option 3350-300)</p>  <p data-bbox="1029 1227 1141 1249">xx1800002858</p> <p data-bbox="1029 1265 1396 1384">For robots with protection class IP54 (option 3350-540) For robots with protection type Clean Room (option 3351-1)</p>  <p data-bbox="1029 1709 1141 1731">xx1900001640</p>

Continues on next page

Refitting the extension shaft for Clean Room/ IP54 robots

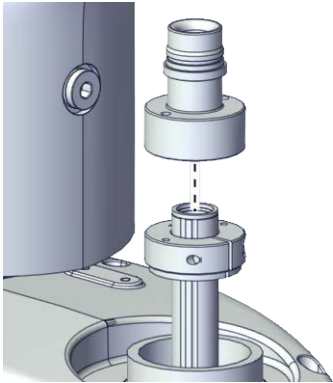
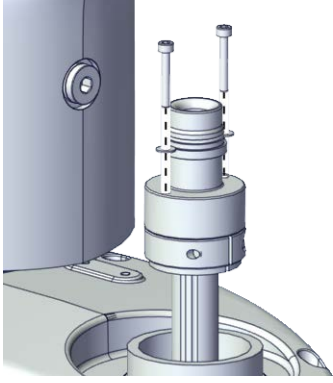
	Action	Note
1	<p>For robots with protection type Clean Room: Clean the joints that have been opened and wipe the parts free from particles with spirit on a lint free. See Cut the paint or surface on the robot before replacing parts on page 118</p> <p> Note</p> <p>After all repair work, wipe the Clean Room robot free from particles with spirit on a lint free cloth.</p>	
2	<p>For robots with protection class IP54 (option 3350-540)</p> <p>For robots with protection type Clean Room (option 3351-1)</p> <p>Install the extension shaft to the ball screw on the upper side of the mechanical stopper.</p>	 <p>xx1900001558</p>
3	<p>For robots with protection class IP54 (option 3350-540)</p> <p>For robots with protection type Clean Room (option 3351-1)</p> <p>Secure the extension shaft to the mechanical stopper with the screws.</p>	<p>For IRB 910INV-3/0.35: Screws: Hex socket head cap screw M3x20 12.9 Lafre 2C2B/FC6.9 (2 pcs) Tightening torque: 1.2 Nm ±10%</p> <p>For IRB 910INV-6/0.55: Screws: Hex socket head cap screw M3x20 12.9 Lafre 2C2B/FC6.9 (2 pcs) Tightening torque: 1.2 Nm ±10%</p>  <p>xx1900001557</p>

Continues on next page

5 Repair

5.6.3 Replacing the pulley on the ball screw upper position

Continued

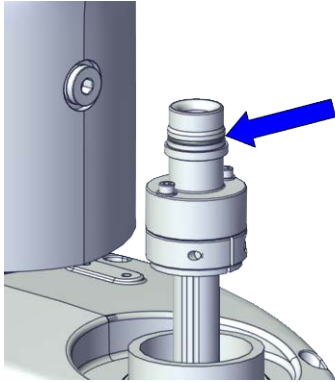
	Action	Note
4	<p>For robots with protection class IP54 (option 3350-540)</p> <p>For robots with protection type Clean Room (option 3351-1)</p> <p>Insert the O-ring to the extension shaft.</p>	 <p>xx1900001556</p>

Refitting the axis-3 timing belt

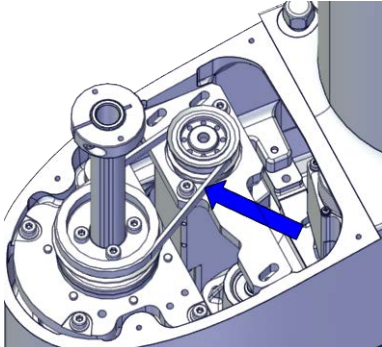
	Action	Note
1	<p>For robots with protection type Clean Room: Clean the joints that have been opened and wipe the parts free from particles with spirit on a lint free. See Cut the paint or surface on the robot before replacing parts on page 118</p> <p> Note</p> <p>After all repair work, wipe the Clean Room robot free from particles with spirit on a lint free cloth.</p>	
2	<p>Refit the timing belt to the pulley on the ball screw and the motor. Ensure that the belt runs correctly in the grooves.</p>	<p>Timing belt: 3HAC061862-001</p>  <p>xx1800002886</p>

Continues on next page

5.6.3 Replacing the pulley on the ball screw upper position

Continued

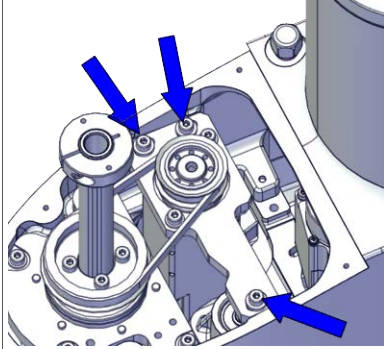
	Action	Note
3	Secure the screws and washers.	<p>Screws: Hex socket head cap screw M4x20 12.9 Lafre 2C2B/FC6.9 (3 pcs)</p> <p>Washers: Washer 4.3x10x2 steel (3 pcs)</p> <p>Tightening torque: 3 Nm \pm10%</p>  <p>xx1800002887</p>
4	Use a sonic tension meter to measure the timing belt tension.	<p>Used belt: 190-232Hz</p> <p>New belt: 225-287Hz</p>
5	If the timing belt tension does not meet the requirement, loosen the motor screws and readjust.	

Refitting the casting cover of the outer arm



	Action	Note
1	<p>For robots with protection type Clean Room: Clean the joints that have been opened and wipe the parts free from particles with spirit on a lint free. See Cut the paint or surface on the robot before replacing parts on page 118</p> <p> Note</p> <p>After all repair work, wipe the Clean Room robot free from particles with spirit on a lint free cloth.</p>	

Continues on next page

5 Repair

5.6.3 Replacing the pulley on the ball screw upper position

Continued

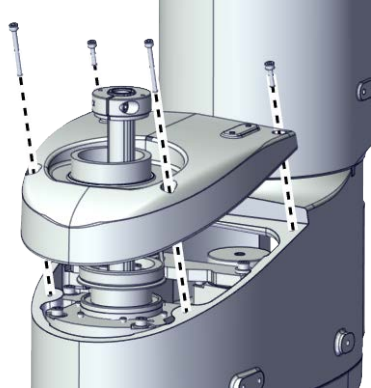
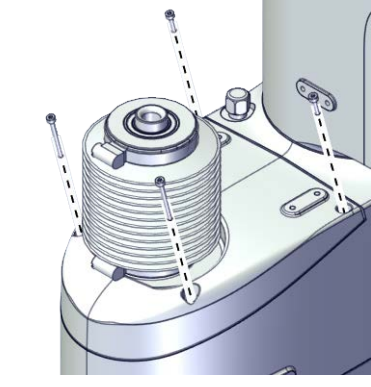
	Action	Note
2	<p>Refit the cover.</p> <p> Note</p> <p>For robots with protection class IP54 (option 3350-540)</p> <p>For robots with protection type Clean Room (option 3351-1)</p> <p>Refit the cover with bellow and housing.</p> <p>Check the gasket on the casting cover.</p> <p> CAUTION</p> <p>There is a gasket in the cover. Be careful when refitting the cover with bellow and housing.</p> <p> Tip</p> <p>Replace the gasket if needed.</p>	<p>Long screw: Hex socket head cap screw M3x30 12.9 Lafre 2C2B/FC6.9 (2 pcs)</p> <p>Tightening torque: 1.2 Nm \pm10%</p> <p>Short screw: Hex socket head cap screw M3x12 12.9 Lafre 2C2B/FC6.9 (2 pcs)</p> <p>Tightening torque: 1.2 Nm \pm10%</p> <p>For robots with protection class IP30 (option 3350-300)</p>  <p>xx1800002883</p> <p>For robots with protection class IP54 (option 3350-540)</p> <p>For robots with protection type Clean Room (option 3351-1)</p>  <p>xx1900001628</p>
3	<p>Refit the screws.</p>	

Refitting the upper cover

	Action	Note
1	<p>For robots with protection type Clean Room:</p> <p>Clean the joints that have been opened and wipe the parts free from particles with spirit on a lint free. See Cut the paint or surface on the robot before replacing parts on page 118</p> <p> Note</p> <p>After all repair work, wipe the Clean Room robot free from particles with spirit on a lint free cloth.</p>	



Continues on next page

5.6.3 Replacing the pulley on the ball screw upper position

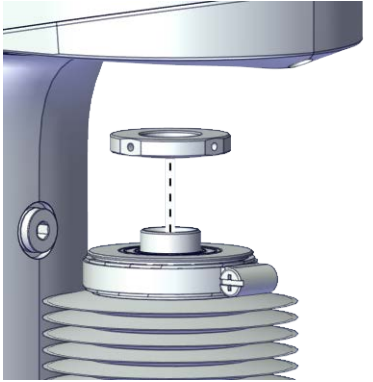
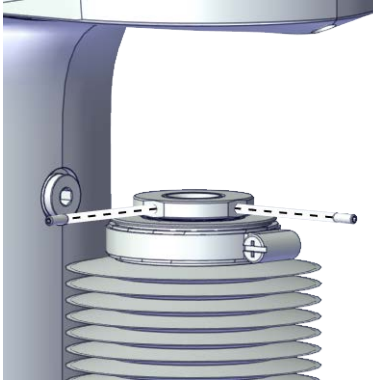
Continued

	Action	Note
2	<p>For robots with protection class IP54 (option 3350-540)</p> <p>For robots with protection type Clean Room (option 3351-1)</p> <p>Refit the upper cover to the ball screw.</p>	 <p>xx1900001548</p>
3	<p>For robots with protection class IP54 (option 3350-540)</p> <p>For robots with protection type Clean Room (option 3351-1)</p> <p>Refit the locking screws.</p>	<p>Screws: Hexagon socket set screws with flat point, ISO 4026 stainless steel M3x8 (2 pcs)</p> <p>Tightening torque: 0.6 Nm ±10%</p>  <p>xx1900001547</p>

Concluding procedure

	Action	Note
1	<p>For robots with protection type Clean Room:</p> <p>Seal and paint the joints that have been opened. See Cut the paint or surface on the robot before replacing parts on page 118</p> <p> Note</p> <p>After all repair work, wipe the Clean Room robot free from particles with spirit on a lint free cloth.</p>	
2	<p>Recalibrate the robot.</p>	<p>Calibration is detailed in section Calibration on page 771.</p>
3	<p> DANGER</p> <p>Make sure all safety requirements are met when performing the first test run. See Test run after installation, maintenance, or repair on page 56.</p>	

5 Repair

5.6.4 Replacing the pulley on the ball screw lower position

5.6.4 Replacing the pulley on the ball screw lower position

Location of the pulley

The pulley is located as shown in the figure.

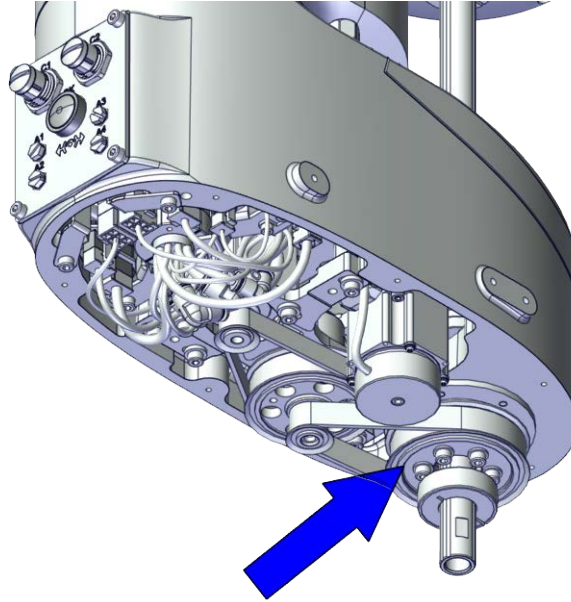

xx1800002864

Required spare parts



Note

The spare part numbers that are listed in the table can be out of date. See the latest spare parts of the IRB 910INV via myABB Business Portal, www.abb.com/myABB.

Spare part	Article number	Note
Pulley Z4/4, 350mm	3HAC061860-001	
Pulley Z4/4, 550mm	3HAC063638-001	
Mechanical-Stop bottom, D16	3HAC073061-001	Used for IRB 910INV-3/0.35
Mechanical-Stop bottom, D20	3HAC073069-001	Used for IRB 910INV-6/0.55
Outer arm cover, 350 mm	3HAC073058-001	
Outer arm cover, 550 mm	3HAC073066-001	
Outer arm cover, 350 mm, Clean Room	3HAC073230-001	Used with protection type Clean Room.
Outer arm cove, 550 mm, Clean Room	3HAC073234-001	Used with protection type Clean Room.
Gasket, cover, 350 mm	3HAC066920-001	Replace if damaged.
Gasket, cover, 550 mm	3HAC066921-001	Replace if damaged.
Pulley pre-assembly	3HAC073057-001	

Continues on next page

5.6.4 Replacing the pulley on the ball screw lower position

*Continued***Required tools and equipment**

Equipment	Article number	Note
Standard toolkit	-	Content is defined in section Standard toolkit on page 840 .
Calibration tool box, Axis Calibration	3HAC074119-001	Delivered as a set of calibration tools. Required if Axis Calibration is the valid calibration method for the robot. ⁱ
24 VDC power supply	-	Used to release the motor brakes.
Belt tension adjustment tool set, stage two of axis 4	-	Included in the special toolkit 3HAC073070-001. Used to adjust the tension of axis-4 timing belt. Special tool for L2
Sonic tension meter	-	Used for measuring the timing belt tension.
Handheld dynamometer	-	Used for measuring the timing belt tension.

ⁱ The robot is calibrated by either manual calibration or Axis Calibration at ABB factory before delivery. Always use the same calibration method as used at the factory. Information about valid calibration method is found on the calibration label or in the calibration menu on the FlexPendant.
If no data is found related to standard calibration, manual calibration is used as default.

Required consumables

Consumable	Article number	Note
Cable straps	-	
Grease	-	THK AFA Used to lubricate the ball screw spline shaft.

Deciding calibration routine

Decide which calibration routine to be used, based on the information in the table. Depending on which routine is chosen, action might be required prior to beginning the repair work of the robot, see the table.

	Action	Note
1	Decide which calibration routine to use for calibrating the robot. <ul style="list-style-type: none"> Reference calibration. External cable packages (DressPack) and tools can stay fitted on the robot. Fine calibration. All external cable packages (DressPack) and tools must be removed from the robot. 	

Continues on next page

5 Repair

5.6.4 Replacing the pulley on the ball screw lower position

Continued

Action	Note
<p>If the robot is to be calibrated with reference calibration: Find previous reference values for the axis or create new reference values. These values are to be used after the repair procedure is completed, for calibration of the robot.</p> <p>If no previous reference values exist, and no new reference values can be created, then reference calibration is not possible.</p>	<p>Follow the instructions given in the reference calibration routine on the FlexPendant to create reference values.</p> <p>Creating new values requires possibility to move the robot.</p> <p>Read more about reference calibration for Axis Calibration in Reference calibration routine on page 798.</p>
<p>If the robot is to be calibrated with fine calibration: Remove all external cable packages (DressPack) and tools from the robot.</p>	

Removing the pulley on the ball screw lower position

Use these procedures to remove the pulley.

Preparations before removing the pulley

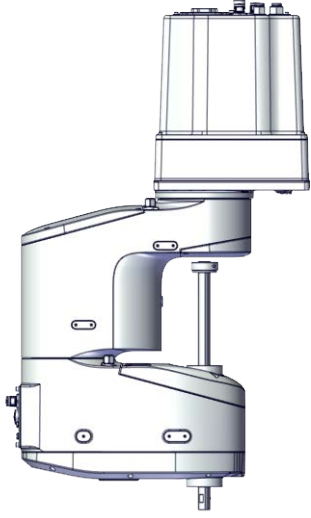

Remove the robot from the wall.

	Action	Note
1	Decide which calibration routine to use, and take actions accordingly prior to beginning the repair procedure.	
2	<p>If there is no enough space for the maintenance work, remove the robot from the wall and place it on the maintenance bracket.</p> <p> CAUTION</p> <p>Do not lay down the robot during the transportation, always keep it straight.</p> <p>If the robot lay down in any situation, the grease may come out from gearbox.</p>	
3	Jog all axes to zero position.	 <p>xx1800002825</p>



Continues on next page

5.6.4 Replacing the pulley on the ball screw lower position

Continued

	Action	Note
4	 DANGER Turn off all: <ul style="list-style-type: none"> • electric power supply • hydraulic pressure supply • air pressure supply to the robot, before entering the safeguarded space.	
5	 CAUTION For robots with protection type Clean Room Always cut the paint with a knife and grind the paint edge when disassembling parts of the robot! See Cut the paint or surface on the robot before replacing parts on page 118 .	

Removing the lower cover

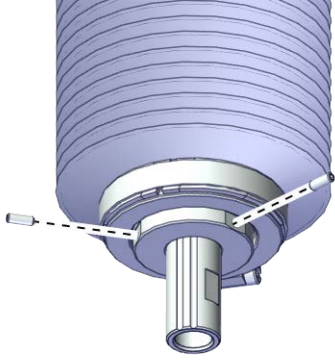
	Action	Note
1	 DANGER Make sure that all supplies for electrical power, hydraulic pressure, and air pressure are turned off.	
2	 CAUTION For robots with protection type Clean Room Always cut the paint with a knife and grind the paint edge when disassembling parts of the robot! See Cut the paint or surface on the robot before replacing parts on page 118 .	
3	For robots with protection class IP54 (option 3350-540) For robots with protection type Clean Room (option 3351-1) Loose the locking screws.	 <p>xx1900001606</p>

Continues on next page



5 Repair

5.6.4 Replacing the pulley on the ball screw lower position

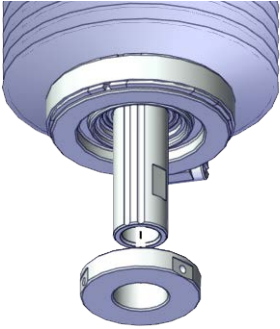
Continued

	Action	Note
4	<p>For robots with protection class IP54 (option 3350-540)</p> <p>For robots with protection type Clean Room (option 3351-1)</p> <p>Remove the lower cover from the ball screw.</p>	 <p>xx1900001607</p>





Removing the cover of the outer arm

	Action	Note
1	 DANGER Make sure that all supplies for electrical power, hydraulic pressure, and air pressure are turned off.	
2	 CAUTION For robots with protection type Clean Room Always cut the paint with a knife and grind the paint edge when disassembling parts of the robot! See Cut the paint or surface on the robot before replacing parts on page 118 .	

Continues on next page

5.6.4 Replacing the pulley on the ball screw lower position

Continued

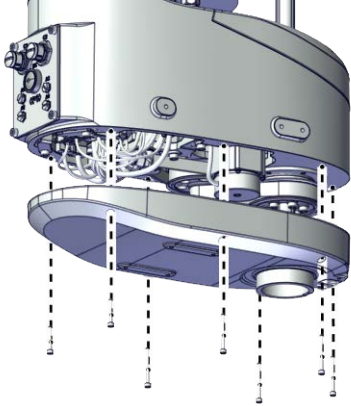
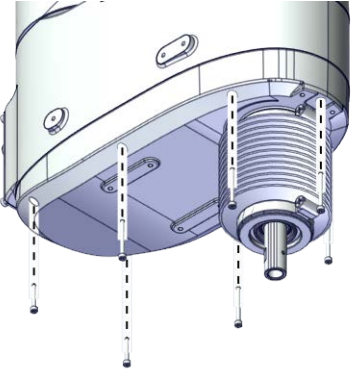
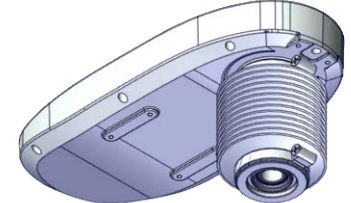
	Action	Note
3	<p>Remove the screws on the cover of the outer arm and remove the cover.</p> <p> Note</p> <p>For robots with protection class IP54 (option 3350-540)</p> <p>For robots with protection type Clean Room (option 3351-1)</p> <p>Remove the cover with bellow and housing.</p> <p> Note</p> <p>The bellow does not need to be removed separately.</p> <p> CAUTION</p> <p>There is a gasket in the cover. Be careful when removing the cover with bellow and housing.</p> <p> Tip</p> <p>Check the gasket and replace it if needed.</p>	<p>For robots with protection class IP30 (option 3350-300)</p>  <p>xx1800002836</p> <p>For robots with protection class IP54 (option 3350-540)</p> <p>For robots with protection type Clean Room (option 3351-1)</p>  <p>xx1900001631</p>  <p>xx1900001632</p>

Removing the axis-4 second timing belt

	Action	Note
1	<p> DANGER</p> <p>Make sure that all supplies for electrical power, hydraulic pressure, and air pressure are turned off.</p>	

Continues on next page



5 Repair

5.6.4 Replacing the pulley on the ball screw lower position

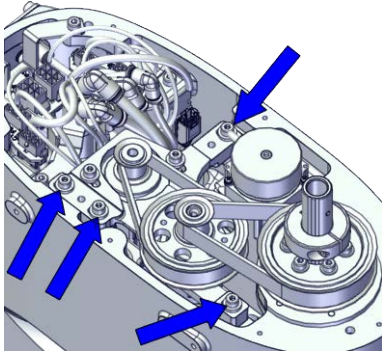
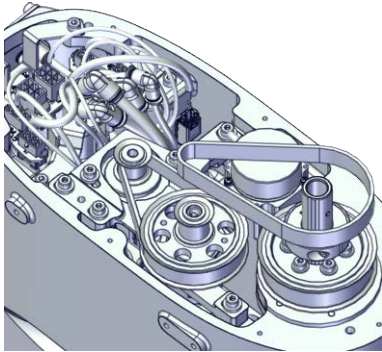
Continued

	Action	Note
2	 CAUTION For robots with protection type Clean Room Always cut the paint with a knife and grind the paint edge when disassembling parts of the robot! See <i>Cut the paint or surface on the robot before replacing parts on page 118.</i>	
3	Loosen the screws of the pulley pre-assembly to let the axis-4 second timing belt be free.	 xx1800003389
4	Remove the timing belt.	 xx1800003390



Removing the shaft for Clean Room/ IP54 robots

	Action	Note
1	 DANGER Make sure that all supplies for electrical power, hydraulic pressure, and air pressure are turned off.	
2	 CAUTION For robots with protection type Clean Room Always cut the paint with a knife and grind the paint edge when disassembling parts of the robot! See <i>Cut the paint or surface on the robot before replacing parts on page 118.</i>	

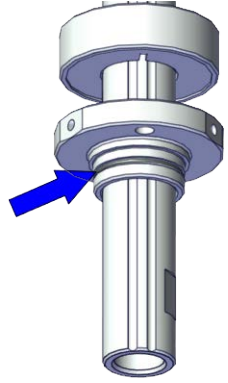
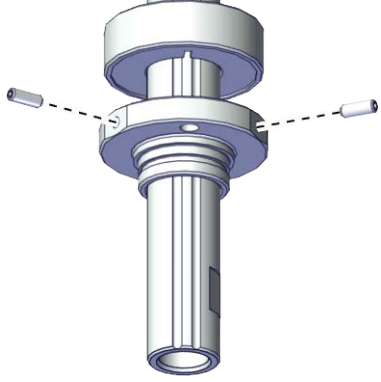

Continues on next page

5.6.4 Replacing the pulley on the ball screw lower position

Continued

	Action	Note
3	<p>For robots with protection class IP54 (option 3350-540) For robots with protection type Clean Room (option 3351-1) Remove the O-ring from the lower housing.</p>	 <p>xx1900001615</p>
4	<p>For robots with protection class IP54 (option 3350-540) For robots with protection type Clean Room (option 3351-1) Loose the attachment screws.</p>	 <p>xx1900001616</p>
5	<p>For robots with protection class IP54 (option 3350-540) For robots with protection type Clean Room (option 3351-1) Remove the shaft from the mechanical stopper.</p> <p> Note The shaft is glued to the ball screw. Be careful with the glue when removing the shaft.</p>	

Removing the lower mechanical stopper



	Action	Note
1	<p> DANGER Make sure that all supplies for electrical power, hydraulic pressure, and air pressure are turned off.</p>	
2	<p> CAUTION For robots with protection type Clean Room Always cut the paint with a knife and grind the paint edge when disassembling parts of the robot! See Cut the paint or surface on the robot before replacing parts on page 118.</p>	

Continues on next page

5 Repair

5.6.4 Replacing the pulley on the ball screw lower position

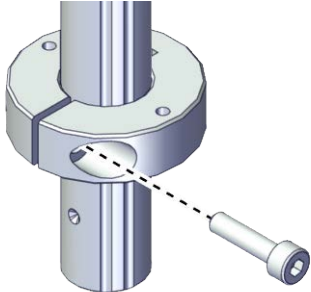
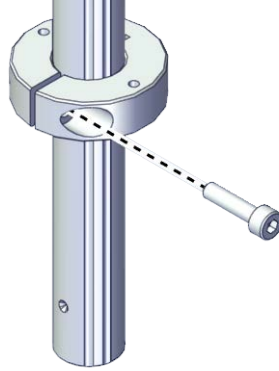
Continued

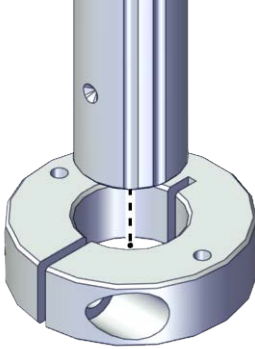
	Action	Note
3	Remove the screw.	<p>For robots with protection class IP30 (option 3350-300)</p>  <p>xx1800002860</p> <p>For robots with protection class IP54 (option 3350-540) For robots with protection type Clean Room (option 3351-1)</p>  <p>xx1900001642</p>
4	<p>Remove the mechanical stopper.</p> <p> CAUTION</p> <p>If the ball screw nut or ball screw spline nut go out of the screw shaft, the ball screw is destroyed. Be careful when you do any work that may cause this.</p>	 <p>xx1800002861</p>





Removing the pulley on the ball screw lower position

	Action	Note
1	<p> DANGER</p> <p>Make sure that all supplies for electrical power, hydraulic pressure, and air pressure are turned off.</p>	

Continues on next page

5.6.4 Replacing the pulley on the ball screw lower position

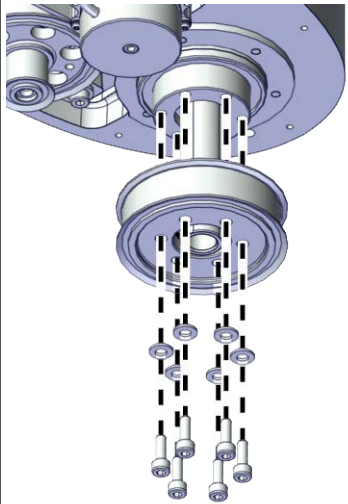
Continued

	Action	Note
2	 ELECTROSTATIC DISCHARGE (ESD) The unit is sensitive to ESD. Before handling the unit read the safety information in section The unit is sensitive to ESD on page 45 .	
3	 CAUTION For robots with protection type Clean Room Always cut the paint with a knife and grind the paint edge when disassembling parts of the robot! See Cut the paint or surface on the robot before replacing parts on page 118 .	
4	Remove the screws and washers.	
5	Remove the pulley carefully.  CAUTION If the ball screw nut or ball screw spline nut go out of the screw shaft, the ball screw is destroyed. Be careful when you do any work that may cause this.	

xx1800002865

Refitting the pulley on the ball screw lower position

Use these procedures to refit the pulley.

Refitting the pulley on the ball screw lower position



	Action	Note
1	 ELECTROSTATIC DISCHARGE (ESD) The unit is sensitive to ESD. Before handling the unit read the safety information in section The unit is sensitive to ESD on page 45 .	

Continues on next page

5 Repair

5.6.4 Replacing the pulley on the ball screw lower position

Continued

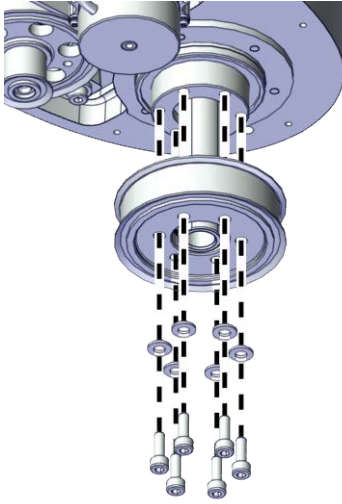

	Action	Note
2	<p>For robots with protection type Clean Room: Clean the joints that have been opened and wipe the parts free from particles with spirit on a lint free. See Cut the paint or surface on the robot before replacing parts on page 118</p> <p> Note</p> <p>After all repair work, wipe the Clean Room robot free from particles with spirit on a lint free cloth.</p>	
3	<p>Refit the pulley to the ball screw carefully.</p> <p> CAUTION</p> <p>If the ball screw nut or ball screw spline nut go out of the screw shaft, the ball screw is destroyed. Be careful when you do any work that may cause this.</p>	<p>For IRB 910INV-3/0.35: Screws: Hex socket head cap screw M4x12 12.9 Lafre 2C2B/FC6.9 (6 pcs) Washers: Spring washer 9x4.3x1 Steel (6 pcs) Tightening torque: 3.8 Nm \pm10%</p> <p>For IRB 910INV-6/0.55: Screws: Hex socket head cap screw M5x12 12.9 Lafre 2C2B/FC6.9 (6 pcs) Washers: Plain washer 11x5.3x1.2 Steel (6 pcs) Tightening torque: 6.5 Nm \pm10%</p>
4	<p>Refit the screws.</p> <p> Tip</p> <p>Secure with the special stopping tool to prevent the pulley from rotating.</p>	<p></p> <p>xx1800002865</p>

Continues on next page

5.6.4 Replacing the pulley on the ball screw lower position

Continued

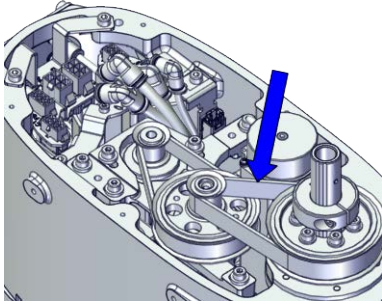
Refitting the axis-4 second timing belt

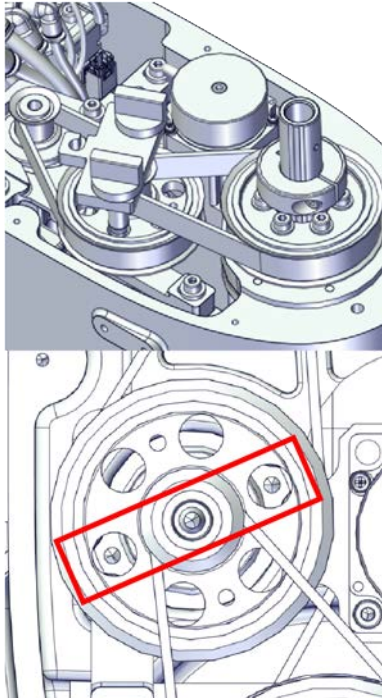

	Action	Note
1	<p>For robots with protection type Clean Room: Clean the joints that have been opened and wipe the parts free from particles with spirit on a lint free. See Cut the paint or surface on the robot before replacing parts on page 118</p> <p> Note</p> <p>After all repair work, wipe the Clean Room robot free from particles with spirit on a lint free cloth.</p>	
2	<p>Refit the timing belt to the pulley and the motor. Ensure that the belt runs correctly in the grooves.</p>	 <p>xx1800002895</p> <p>Timing belt: 3HAC061864-001</p>
3	<p>Install the axis-4 belt tension adjustment tool to the motor.</p> <p> Note</p> <p>Just tighten the tool.</p>	<p>Belt tension adjustment tool set, stage two of axis 4:-</p>  <p>xx1900000096</p>

Continues on next page

5 Repair

5.6.4 Replacing the pulley on the ball screw lower position

Continued

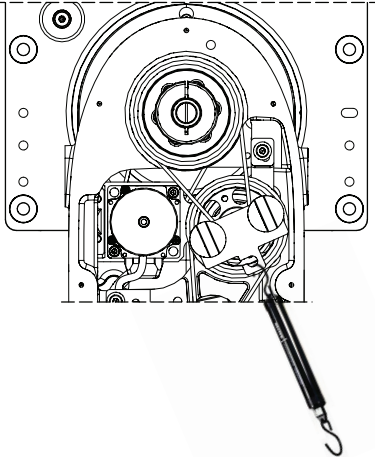
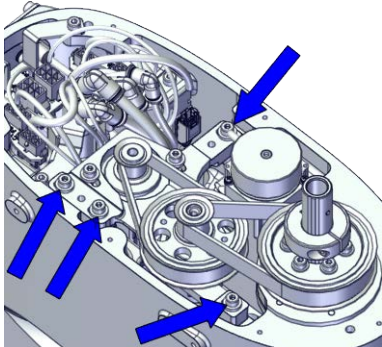
	Action	Note
4	<p>Use a handheld dynamometer hooking to the screw and pull the dynamometer to make the tension falling in the allowed force range.</p> <p> Note</p> <p>During the measurement, make sure that all interferences that may affect the force are removed. Pay attention to the force application direction.</p> <p> Tip</p> <p>If the ball screw will interfere with the handheld dynamometer, adjust the ball screw manually.</p>	<p>Used belt: 84-96N New belt:120-132N</p>  <p>xx190000097</p>
5	<p>Fasten the screws to the recommended tightening torque.</p>	<p>Tightening torque: 3 Nm \pm10%</p>  <p>xx1800003389</p>
6	<p>Use a sonic tension meter to measure the timing belt tension.</p>	<p>Used belt: 257-314Hz New belt:304-389Hz</p>
7	<p>If the timing belt tension does not meet the requirement, loosen the motor screws and readjust.</p>	
8	<p>Remove the axis-4 belt tension adjustment tool.</p>	





Refitting the mechanical stopper

	Action	Note
1	<p>For robots with protection type Clean Room: Clean the joints that have been opened and wipe the parts free from particles with spirit on a lint free. See Cut the paint or surface on the robot before replacing parts on page 118</p> <p> Note</p> <p>After all repair work, wipe the Clean Room robot free from particles with spirit on a lint free cloth.</p>	

Continues on next page

5.6.4 Replacing the pulley on the ball screw lower position

Continued

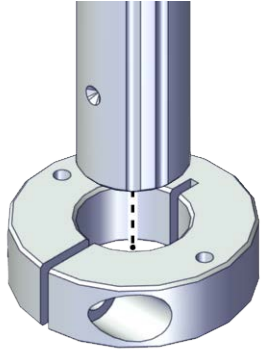
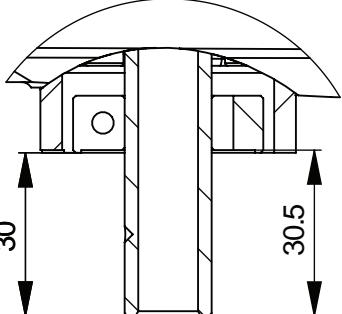
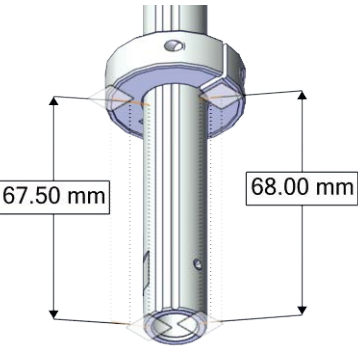
	Action	Note
2	<p>Refit the mechanical stopper to the ball screw at 30.5 mm position to the lower of the ball screw.</p> <p> Note</p> <p>For robots with protection class IP54 (option 3350-540) For robots with protection type Clean Room (option 3351-1) For IRB 910INV-3/0.35, refit the mechanical stopper to the ball screw at 68 mm position to the lower of the ball screw. For IRB 910INV-6/0.55, refit the mechanical stopper to the ball screw at 75.8 mm position to the lower of the ball screw.</p> <p> Tip</p> <p>Make sure that the limit block opening gap is aligned with the ball screw origin point.</p> <p> CAUTION</p> <p>If the ball screw nut or ball screw spline nut go out of the screw shaft, the ball screw is destroyed. Be careful when you do any work that may cause this.</p> <p> Note</p> <p>Be careful with the orientation of the mechanical stopper. The flat side is on the upper side.</p>	 <p>xx1800002861</p> <p>For robots with protection class IP30 (option 3350-300)</p>  <p>xx1900000144</p> <p>For robots with protection class IP54 (option 3350-540) For robots with protection type Clean Room (option 3351-1) For IRB 910INV-3/0.35</p>  <p>xx1900001641</p> <p>For IRB 910INV-6/0.55</p>

Continues on next page

5 Repair

5.6.4 Replacing the pulley on the ball screw lower position

Continued

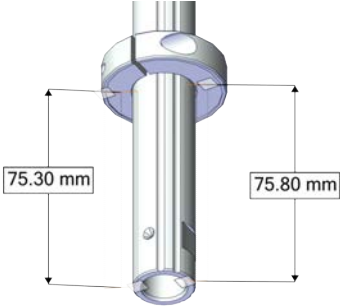
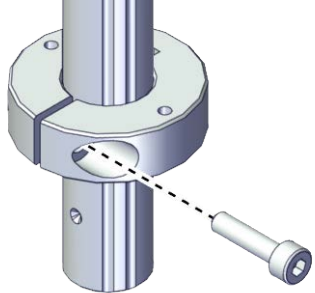
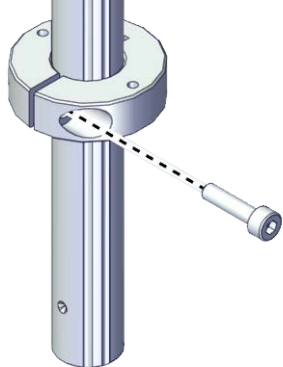
	Action	Note
		 <p>xx1900002004</p>
3	Refit the screw.	<p>Screws: Hex socket head cap screw M4x16 12.9 Lafre 2C2B/FC6.9 (1 pcs) Tightening torque: 6.5 Nm \pm10% For robots with protection class IP30 (option 3350-300)</p>  <p>xx1800002860</p> <p>For robots with protection class IP54 (option 3350-540) For robots with protection type Clean Room (option 3351-1)</p>  <p>xx1900001642</p>

Continues on next page

5.6.4 Replacing the pulley on the ball screw lower position

Continued

Refitting the shaft for Clean Room/ IP54 robots

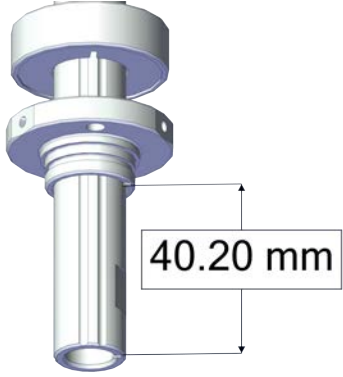
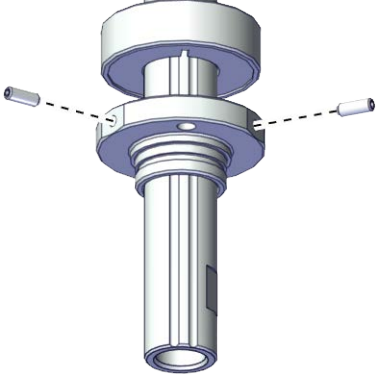
	Action	Note
1	<p>For robots with protection type Clean Room: Clean the joints that have been opened and wipe the parts free from particles with spirit on a lint free. See Cut the paint or surface on the robot before replacing parts on page 118</p> <p> Note</p> <p>After all repair work, wipe the Clean Room robot free from particles with spirit on a lint free cloth.</p>	
2	<p>For robots with protection class IP54 (option 3350-540)</p> <p>For robots with protection type Clean Room (option 3351-1)</p> <p>Install the shaft to the ball screw at 40.2 mm position to the lower of the ball screw.</p>	 <p>xx1900001617</p>
3	<p>For robots with protection class IP54 (option 3350-540)</p> <p>For robots with protection type Clean Room (option 3351-1)</p> <p>Secure the shaft to the ball screw with the screws.</p>	<p>Screws: Hexagon socket set screws with flat point, ISO 4026 stainless steel M3x8 (2 pcs)</p> <p>Tightening torque: 1.2 Nm ±10%</p>  <p>xx1900001616</p>

Continues on next page

5 Repair

5.6.4 Replacing the pulley on the ball screw lower position

Continued

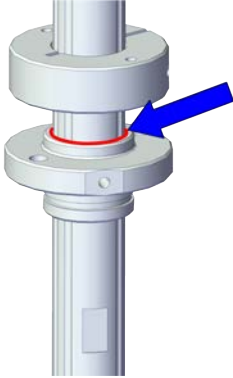
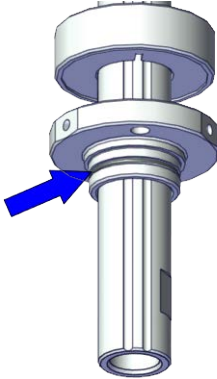
	Action	Note
4	<p>For robots with protection class IP54 (option 3350-540)</p> <p>Apply the glue to the upper contacted zone between the shaft and the ball screw.</p> <p> Note</p> <p>Fulfill the gaps on the ball screw in this contacted zone to make a sealing structure.</p>	 <p>xx1900001805</p>
5	<p>For robots with protection class IP54 (option 3350-540)</p> <p>For robots with protection type Clean Room (option 3351-1)</p> <p>Insert the O-ring to the shaft.</p>	 <p>xx1900001615</p>



Refitting the cover of the outer arm

	Action	Note
1	<p>For robots with protection type Clean Room:</p> <p>Clean the joints that have been opened and wipe the parts free from particles with spirit on a lint free. See Cut the paint or surface on the robot before replacing parts on page 118</p> <p> Note</p> <p>After all repair work, wipe the Clean Room robot free from particles with spirit on a lint free cloth.</p>	

Continues on next page

5.6.4 Replacing the pulley on the ball screw lower position

Continued

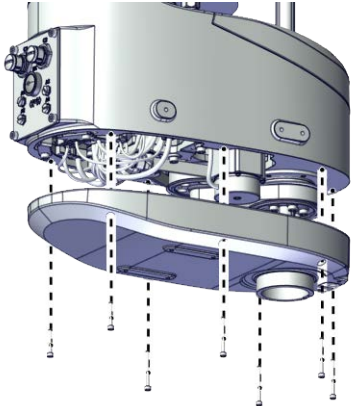
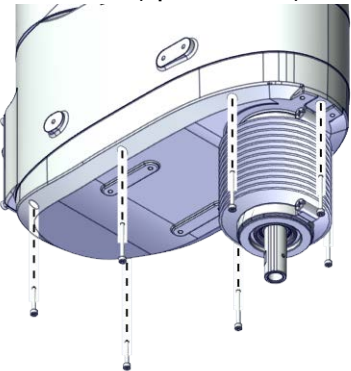
	Action	Note
2	<p>Refit the cover.</p> <p> Note</p> <p>For robots with protection class IP54 (option 3350-540)</p> <p>For robots with protection type Clean Room (option 3351-1)</p> <p>Refit the cover with bellow and housing.</p> <p>Check the gasket on the outer arm cover.</p> <p> Tip</p> <p>Replace the gasket if needed.</p>	<p>For IRB 910INV-3/0.35:</p> <p>Screw: Hex socket head cap screw M3x20 12.9 Lafre 2C2B/FC6.9 (2 pcs)</p> <p>Hex socket head cap screw M3x30 12.9 Lafre 2C2B/FC6.9 (5 pcs)</p> <p>Tightening torque: 1.2 Nm ±10%</p> <p>For IRB 910INV-6/0.55:</p> <p>Screw: Hex socket head cap screw M3x20 12.9 Lafre 2C2B/FC6.9 (2 pcs)</p> <p>Hex socket head cap screw M3x30 12.9 Lafre 2C2B/FC6.9 (7 pcs)</p> <p>Tightening torque: 1.2 Nm ±10%</p> <p>For robots with protection class IP30 (option 3350-300)</p>
3	<p>Refit the screws.</p>	 <p>xx1800002836</p> <p>For robots with protection class IP54 (option 3350-540)</p> <p>For robots with protection type Clean Room (option 3351-1)</p>  <p>xx1900001631</p>

Continues on next page

5 Repair

5.6.4 Replacing the pulley on the ball screw lower position

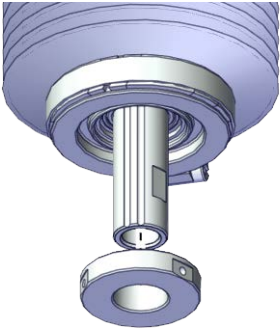
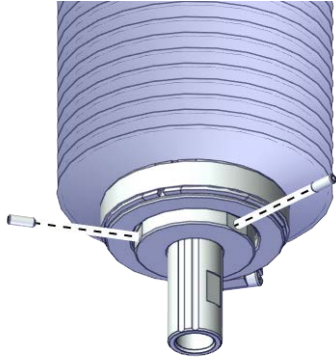

Continued

Refitting the lower cover

	Action	Note
1	<p>For robots with protection type Clean Room: Clean the joints that have been opened and wipe the parts free from particles with spirit on a lint free. See Cut the paint or surface on the robot before replacing parts on page 118</p> <p> Note</p> <p>After all repair work, wipe the Clean Room robot free from particles with spirit on a lint free cloth.</p>	
2	<p>For robots with protection class IP54 (option 3350-540)</p> <p>For robots with protection type Clean Room (option 3351-1)</p> <p>Refit the lower cover to the ball screw.</p>	 <p>xx1900001607</p>
3	<p>For robots with protection class IP54 (option 3350-540)</p> <p>For robots with protection type Clean Room (option 3351-1)</p> <p>Refit the locking screws.</p>	<p>Screws: Hexagon socket set screws with flat point, ISO 4026 stainless steel M3x8 (2 pcs)</p> <p>Tightening torque: 0.6 Nm \pm10%</p>  <p>xx1900001606</p>

Continues on next page

Concluding procedure

	Action	Note
1	<p>For robots with protection type Clean Room: Seal and paint the joints that have been opened. See Cut the paint or surface on the robot before replacing parts on page 118</p> <p> Note</p> <p>After all repair work, wipe the Clean Room robot free from particles with spirit on a lint free cloth.</p>	
2	Recalibrate the robot.	Calibration is detailed in section Calibration on page 771 .
3	<p> DANGER</p> <p>Make sure all safety requirements are met when performing the first test run. See Test run after installation, maintenance, or repair on page 56.</p>	

5 Repair

5.6.5 Replacing the ball screw

5.6.5 Replacing the ball screw

Location of the ball screw

The ball screw is located as shown in the figure.

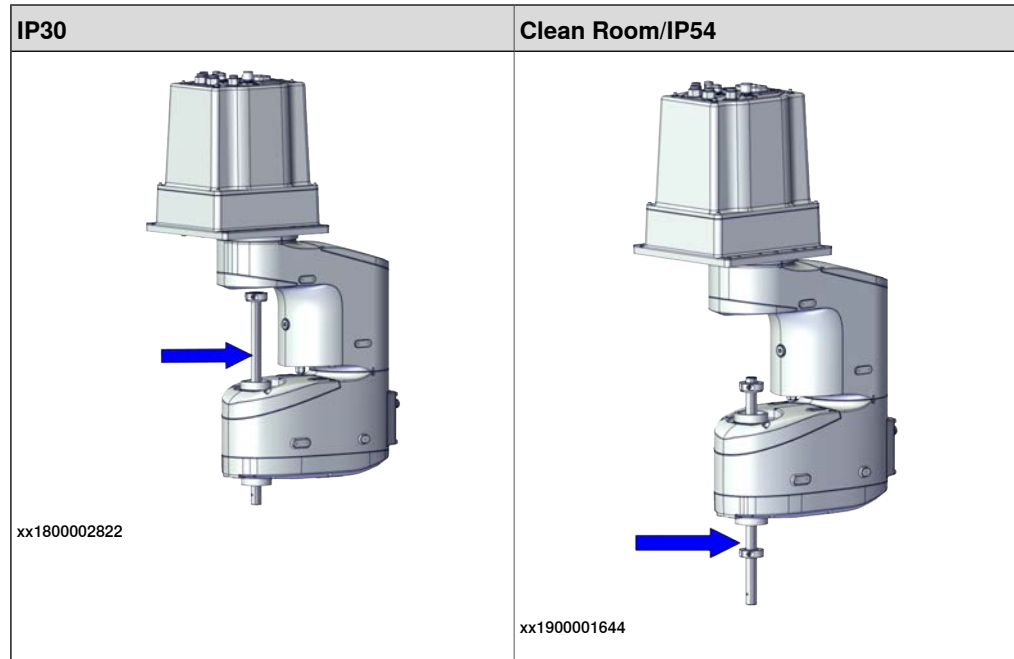

CAUTION

For the robots with protection type Clean Room and protection class IP54, the ball screw spline unit is inside the bellows. If needed, remove the bellows to inspect the ball screw spline unit.

For details about how to remove the bellows, see [Replacing the bellows](#).

Required spare parts



Note

The spare part numbers that are listed in the table can be out of date. See the latest spare parts of the IRB 910INV via myABB Business Portal, www.abb.com/myABB.

Spare part	Article number	Note
Ball screw	3HAC061865-001	BNS1616A+330LC5 Used for IRB 910INV-3/0.35
Ball screw	3HAC063635-001	BNS2020A, Short Used for IRB 910INV-6/0.55

Continues on next page

Required tools and equipment

Equipment	Article number	Note
Standard toolkit	-	Content is defined in section Standard toolkit on page 840 .
Calibration tool box, Axis Calibration	3HAC074119-001	Delivered as a set of calibration tools. Required if Axis Calibration is the valid calibration method for the robot. ⁱ
24 VDC power supply	-	Used to release the motor brakes.
Belt tension adjustment tool set, stage two of axis 4	-	Included in the special toolkit 3HAC073070-001. Used to adjust the tension of axis-4 timing belt. Special tool for L2
Sonic tension meter	-	Used for measuring the timing belt tension.
Handheld dynamometer	-	Used for measuring the timing belt tension.

ⁱ The robot is calibrated by either manual calibration or Axis Calibration at ABB factory before delivery. Always use the same calibration method as used at the factory. Information about valid calibration method is found on the calibration label or in the calibration menu on the FlexPendant.
If no data is found related to standard calibration, manual calibration is used as default.

Required consumables

Consumable	Article number	Note
Cable straps	-	
Grease	-	THK AFA Used to lubricate the ball screw spline shaft.
Sealing compound	3HAC026759-002	Sikaflex 521 FC For robots with protection type Clean Room.

Deciding calibration routine

Decide which calibration routine to be used, based on the information in the table. Depending on which routine is chosen, action might be required prior to beginning the repair work of the robot, see the table.

	Action	Note
1	Decide which calibration routine to use for calibrating the robot. <ul style="list-style-type: none"> Reference calibration. External cable packages (DressPack) and tools can stay fitted on the robot. Fine calibration. All external cable packages (DressPack) and tools must be removed from the robot. 	

Continues on next page

5 Repair

5.6.5 Replacing the ball screw

Continued

Action	Note
<p>If the robot is to be calibrated with reference calibration: Find previous reference values for the axis or create new reference values. These values are to be used after the repair procedure is completed, for calibration of the robot.</p> <p>If no previous reference values exist, and no new reference values can be created, then reference calibration is not possible.</p>	<p>Follow the instructions given in the reference calibration routine on the FlexPendant to create reference values.</p> <p>Creating new values requires possibility to move the robot.</p> <p>Read more about reference calibration for Axis Calibration in Reference calibration routine on page 798.</p>
<p>If the robot is to be calibrated with fine calibration: Remove all external cable packages (DressPack) and tools from the robot.</p>	



Removing the ball screw

Use these procedures to remove the ball screw.

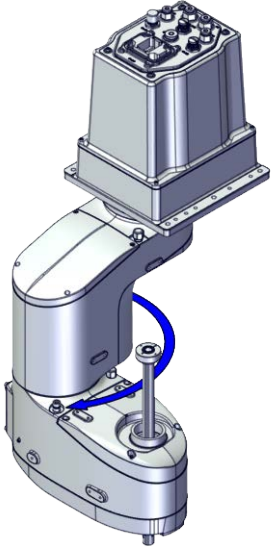

Preparations before removing the ball screw

	Action	Note
1	Decide which calibration routine to use, and take actions accordingly prior to beginning the repair procedure.	
2	<p>If there is no enough space for the maintenance work, remove the robot from the wall and place it on the maintenance bracket.</p> <p> CAUTION</p> <p>Do not lay down the robot during the transportation, always keep it straight.</p> <p>If the robot lay down in any situation, the grease may come out from gearbox.</p>	
3	Jog the outer arm to access the casting cover screws.	 <p>xx1800003407</p>

Continues on next page

	Action	Note
4	 DANGER Turn off all: <ul style="list-style-type: none"> • electric power supply • hydraulic pressure supply • air pressure supply to the robot, before entering the safeguarded space.	
5	 CAUTION For robots with protection type Clean Room Always cut the paint with a knife and grind the paint edge when disassembling parts of the robot! See Cut the paint or surface on the robot before replacing parts on page 118 .	

Removing the lower cover

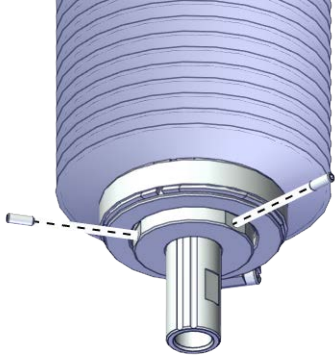
	Action	Note
1	 DANGER Make sure that all supplies for electrical power, hydraulic pressure, and air pressure are turned off.	
2	 CAUTION For robots with protection type Clean Room Always cut the paint with a knife and grind the paint edge when disassembling parts of the robot! See Cut the paint or surface on the robot before replacing parts on page 118 .	
3	For robots with protection class IP54 (option 3350-540) For robots with protection type Clean Room (option 3351-1) Loose the locking screws.	 <p>xx1900001606</p>

Continues on next page



5 Repair

5.6.5 Replacing the ball screw

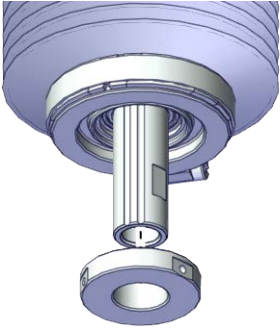
Continued





	Action	Note
4	<p>For robots with protection class IP54 (option 3350-540)</p> <p>For robots with protection type Clean Room (option 3351-1)</p> <p>Remove the lower cover from the ball screw.</p>	 <p>xx1900001607</p>

Removing the cover of the outer arm

	Action	Note
1	 <p>DANGER</p> <p>Make sure that all supplies for electrical power, hydraulic pressure, and air pressure are turned off.</p>	
2	 <p>CAUTION</p> <p>For robots with protection type Clean Room</p> <p>Always cut the paint with a knife and grind the paint edge when disassembling parts of the robot! See Cut the paint or surface on the robot before replacing parts on page 118.</p>	

Continues on next page

5.6.5 Replacing the ball screw
Continued

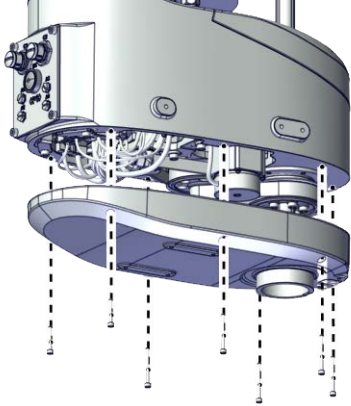
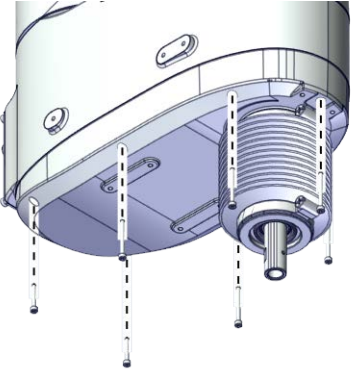
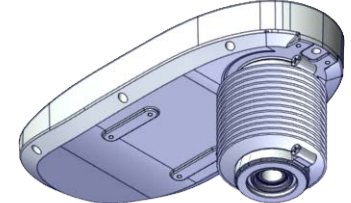
	Action	Note
3	<p>Remove the screws on the cover of the outer arm and remove the cover.</p> <p> Note</p> <p>For robots with protection class IP54 (option 3350-540)</p> <p>For robots with protection type Clean Room (option 3351-1)</p> <p>Remove the cover with bellow and housing.</p> <p> Note</p> <p>The bellow does not need to be removed separately.</p> <p> CAUTION</p> <p>There is a gasket in the cover. Be careful when removing the cover with bellow and housing.</p> <p> Tip</p> <p>Check the gasket and replace it if needed.</p>	<p>For robots with protection class IP30 (option 3350-300)</p>  <p>xx1800002836</p> <p>For robots with protection class IP54 (option 3350-540)</p> <p>For robots with protection type Clean Room (option 3351-1)</p>  <p>xx1900001631</p>  <p>xx1900001632</p>

Removing the axis-4 second timing belt

	Action	Note
1	<p> DANGER</p> <p>Make sure that all supplies for electrical power, hydraulic pressure, and air pressure are turned off.</p>	

Continues on next page



5 Repair

5.6.5 Replacing the ball screw

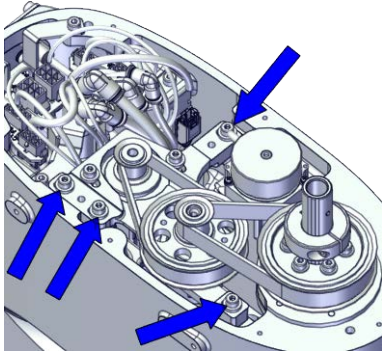
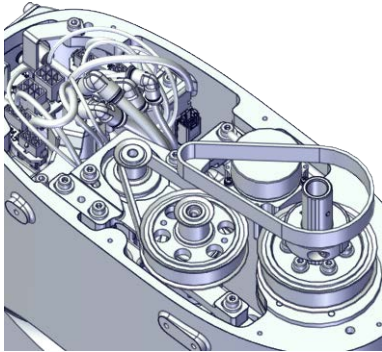
Continued



	Action	Note
2	 CAUTION For robots with protection type Clean Room Always cut the paint with a knife and grind the paint edge when disassembling parts of the robot! See Cut the paint or surface on the robot before replacing parts on page 118.	
3	Loosen the screws of the pulley pre-assembly to let the axis-4 second timing belt be free.	 xx1800003389
4	Remove the timing belt.	 xx1800003390

Removing the shaft for Clean Room/ IP54 robots

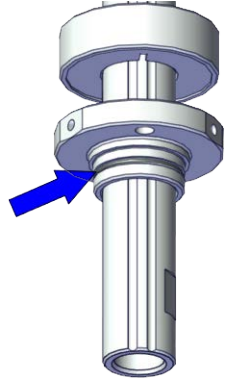
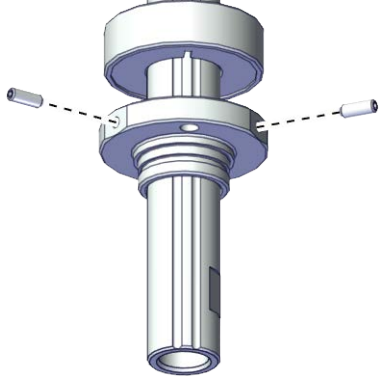

	Action	Note
1	 DANGER Make sure that all supplies for electrical power, hydraulic pressure, and air pressure are turned off.	
2	 CAUTION For robots with protection type Clean Room Always cut the paint with a knife and grind the paint edge when disassembling parts of the robot! See Cut the paint or surface on the robot before replacing parts on page 118.	

Continues on next page

5.6.5 Replacing the ball screw
Continued

	Action	Note
3	<p>For robots with protection class IP54 (option 3350-540) For robots with protection type Clean Room (option 3351-1) Remove the O-ring from the lower housing.</p>	 <p>xx1900001615</p>
4	<p>For robots with protection class IP54 (option 3350-540) For robots with protection type Clean Room (option 3351-1) Loose the attachment screws.</p>	 <p>xx1900001616</p>
5	<p>For robots with protection class IP54 (option 3350-540) For robots with protection type Clean Room (option 3351-1) Remove the shaft from the mechanical stopper.</p> <p> Note The shaft is glued to the ball screw. Be careful with the glue when removing the shaft.</p>	

Removing the lower mechanical stopper



	Action	Note
1	<p> DANGER Make sure that all supplies for electrical power, hydraulic pressure, and air pressure are turned off.</p>	
2	<p> CAUTION For robots with protection type Clean Room Always cut the paint with a knife and grind the paint edge when disassembling parts of the robot! See Cut the paint or surface on the robot before replacing parts on page 118.</p>	

Continues on next page

5 Repair

5.6.5 Replacing the ball screw

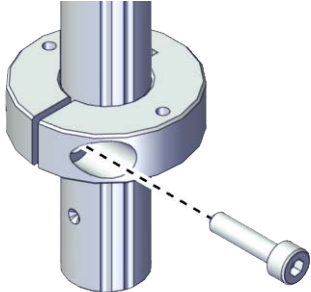
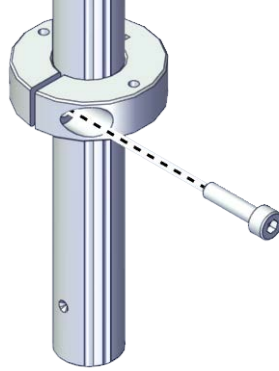

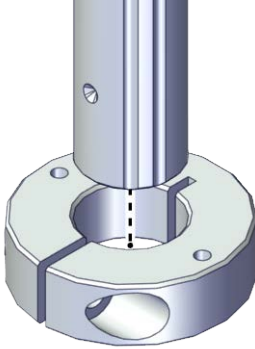

Continued

	Action	Note
3	Remove the screw.	<p>For robots with protection class IP30 (option 3350-300)</p>  <p>xx1800002860</p> <p>For robots with protection class IP54 (option 3350-540) For robots with protection type Clean Room (option 3351-1)</p>  <p>xx1900001642</p>
4	<p>Remove the mechanical stopper.</p> <p> CAUTION</p> <p>If the ball screw nut or ball screw spline nut go out of the screw shaft, the ball screw is destroyed. Be careful when you do any work that may cause this.</p>	 <p>xx1800002861</p>

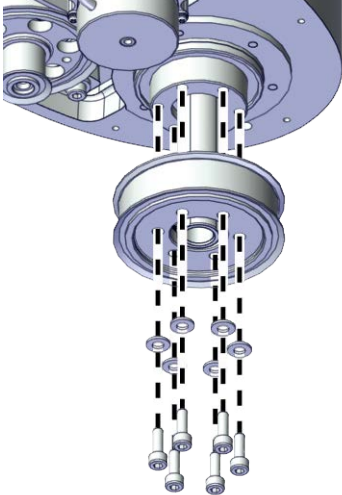

Removing the pulley on the ball screw lower position

	Action	Note
1	<p> DANGER</p> <p>Make sure that all supplies for electrical power, hydraulic pressure, and air pressure are turned off.</p>	

Continues on next page

	Action	Note
2	 ELECTROSTATIC DISCHARGE (ESD) The unit is sensitive to ESD. Before handling the unit read the safety information in section The unit is sensitive to ESD on page 45 .	
3	 CAUTION For robots with protection type Clean Room Always cut the paint with a knife and grind the paint edge when disassembling parts of the robot! See Cut the paint or surface on the robot before replacing parts on page 118 .	
4	Remove the screws and washers.	
5	Remove the pulley carefully.  CAUTION If the ball screw nut or ball screw spline nut go out of the screw shaft, the ball screw is destroyed. Be careful when you do any work that may cause this.	

Removing the upper cover

	Action	Note
1	 DANGER Make sure that all supplies for electrical power, hydraulic pressure, and air pressure are turned off.	
2	 CAUTION For robots with protection type Clean Room Always cut the paint with a knife and grind the paint edge when disassembling parts of the robot! See Cut the paint or surface on the robot before replacing parts on page 118 .	

Continues on next page



5 Repair

5.6.5 Replacing the ball screw

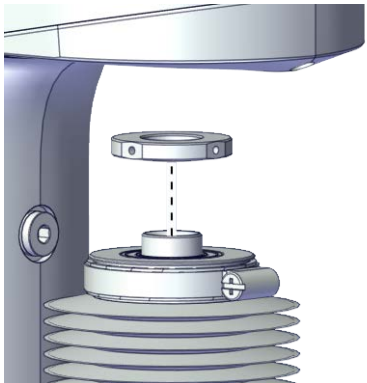
Continued





	Action	Note
3	<p>For robots with protection class IP54 (option 3350-540)</p> <p>For robots with protection type Clean Room (option 3351-1)</p> <p>Loose the locking screws.</p>	 <p>xx1900001547</p>
4	<p>For robots with protection class IP54 (option 3350-540)</p> <p>For robots with protection type Clean Room (option 3351-1)</p> <p>Remove the upper cover from the ball screw.</p>	 <p>xx1900001548</p>

Removing the casting cover of the outer arm

	Action	Note
1	 <p>DANGER</p> <p>Make sure that all supplies for electrical power, hydraulic pressure, and air pressure are turned off.</p>	
2	 <p>CAUTION</p> <p>For robots with protection type Clean Room</p> <p>Always cut the paint with a knife and grind the paint edge when disassembling parts of the robot! See Cut the paint or surface on the robot before replacing parts on page 118.</p>	

Continues on next page

5.6.5 Replacing the ball screw
Continued

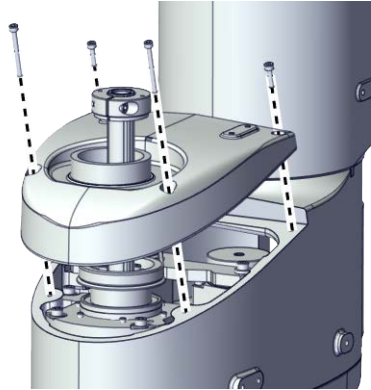
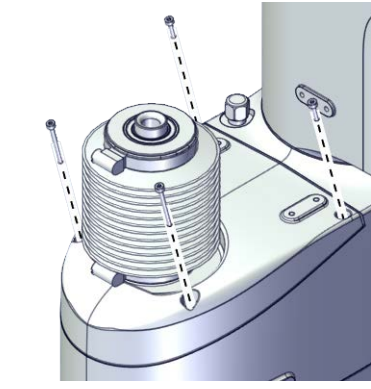
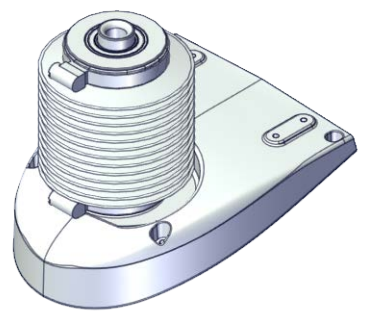
	Action	Note
3	<p>Remove the screws on the casting cover of the outer arm and remove the cover.</p> <p> Note</p> <p>For robots with protection class IP54 (option 3350-540)</p> <p>For robots with protection type Clean Room (option 3351-1)</p> <p>Remove the cover with bellow and housing.</p> <p> Note</p> <p>The bellow does not need to be removed separately.</p> <p> CAUTION</p> <p>There is a gasket in the cover. Be careful when removing the cover with bellow and housing.</p> <p> Tip</p> <p>Check the gasket and replace it if needed.</p>	<p>For robots with protection class IP30 (option 3350-300)</p>  <p>xx1800002883</p> <p>For robots with protection class IP54 (option 3350-540)</p> <p>For robots with protection type Clean Room (option 3351-1)</p>  <p>xx1900001628</p>  <p>xx1900001629</p>

Removing the axis-3 timing belt



	Action	Note
1	<p> DANGER</p> <p>Make sure that all supplies for electrical power, hydraulic pressure, and air pressure are turned off.</p>	

Continues on next page

5 Repair

5.6.5 Replacing the ball screw



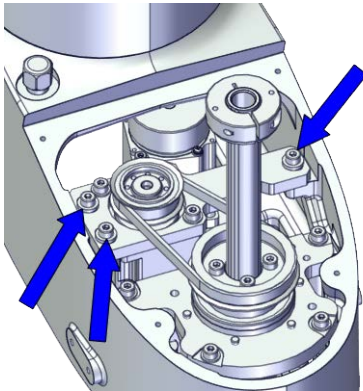
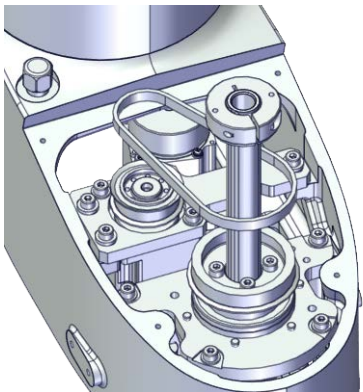



Continued

	Action	Note
2	 CAUTION For robots with protection type Clean Room Always cut the paint with a knife and grind the paint edge when disassembling parts of the robot! See <i>Cut the paint or surface on the robot before replacing parts on page 118.</i>	
3	 DANGER Make sure that the ball screw is supported with something. The sudden drop of the ball screw due the lost of the axis-3 motor may cause danger.	
4	Loosen the screws of the axis-3 motor sub-assembly to let the axis-3 timing belt free.	 xx1800003391
5	Remove the timing belt.	 xx1800003392

Removing the ball screw assembly

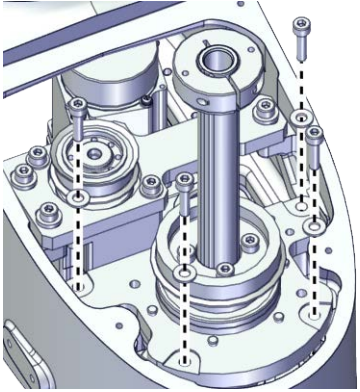
	Action	Note
1	 DANGER Make sure that all supplies for electrical power, hydraulic pressure, and air pressure are turned off.	

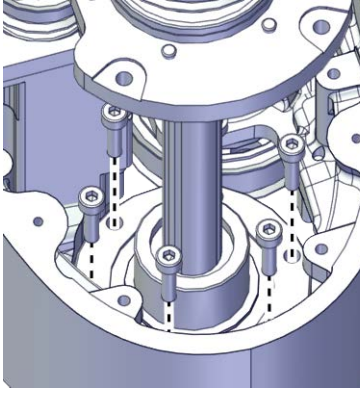
Continues on next page

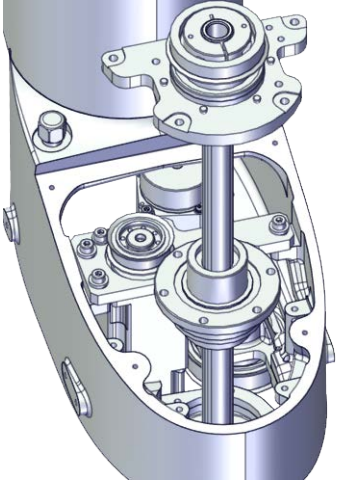
	Action	Note
2	<p> CAUTION</p> <p>For robots with protection type Clean Room Always cut the paint with a knife and grind the paint edge when disassembling parts of the robot! See <i>Cut the paint or surface on the robot before replacing parts on page 118.</i></p>	
3	<p>Remove the screws and washers on the adaptor to the outer arm.</p> <p> Tip</p> <p>Hold the ball screw to prevent it from dropping. Or the ball screw may be destroyed.</p>	 <p>xx1800003393</p>
4	<p>Raise the upper part of the ball screw with the adaptor and remove the screws on the lower part of the ball screw to the outer arm.</p> <p> Tip</p> <p>Hold the ball screw to prevent it from dropping. Or the ball screw may be destroyed.</p>	 <p>xx1800003394</p>
5	<p>Remove the ball screw assembly from the outer arm carefully.</p> <p> Tip</p> <p>Hold the lower part of the ball screw to prevent it from dropping. Or the ball screw may be destroyed.</p> <p> CAUTION</p> <p>If the ball screw nut or ball screw spline nut go out of the screw shaft, the ball screw is destroyed. Be careful when you do any work that may cause this.</p>	 <p>xx1800003395</p>

Continues on next page



5 Repair

5.6.5 Replacing the ball screw

Continued

	Action	Note
6	<p>Lay down the ball screw assembly.</p> <p> CAUTION</p> <p>If the ball screw nut or ball screw spline nut go out of the screw shaft, the ball screw is destroyed. Be careful when you do any work that may cause this.</p>	

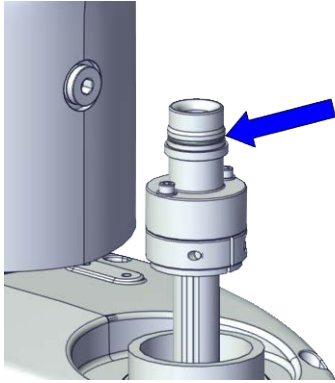
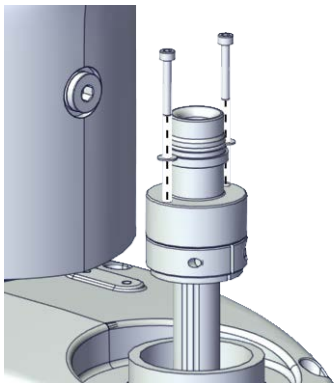

Removing the extension shaft for Clean Room/ IP54 robots

	Action	Note
1	<p> DANGER</p> <p>Make sure that all supplies for electrical power, hydraulic pressure, and air pressure are turned off.</p>	
2	<p> CAUTION</p> <p>For robots with protection type Clean Room Always cut the paint with a knife and grind the paint edge when disassembling parts of the robot! See Cut the paint or surface on the robot before replacing parts on page 118.</p>	
3	<p>For robots with protection class IP54 (option 3350-540) For robots with protection type Clean Room (option 3351-1) Remove the O-ring from the upper housing.</p>	 <p>xx1900001556</p>
4	<p>For robots with protection class IP54 (option 3350-540) For robots with protection type Clean Room (option 3351-1) Loose the attachment screws.</p>	 <p>xx1900001557</p>

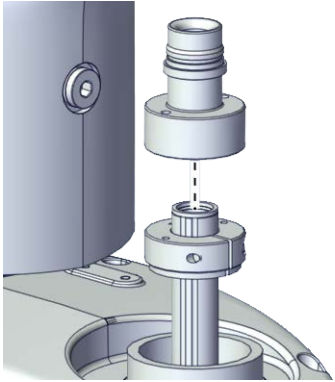
Continues on next page

	Action	Note
5	<p>For robots with protection class IP54 (option 3350-540) For robots with protection type Clean Room (option 3351-1) Remove the extension shaft from the mechanical stopper.</p>	 <p>xx1900001558</p>

Removing the upper mechanical stopper



	Action	Note
1	<p> DANGER</p> <p>Make sure that all supplies for electrical power, hydraulic pressure, and air pressure are turned off.</p>	
2	<p> CAUTION</p> <p>For robots with protection type Clean Room Always cut the paint with a knife and grind the paint edge when disassembling parts of the robot! See Cut the paint or surface on the robot before replacing parts on page 118.</p>	

Continues on next page

5 Repair



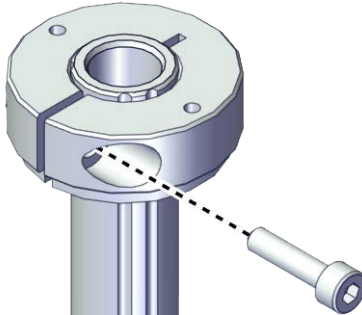
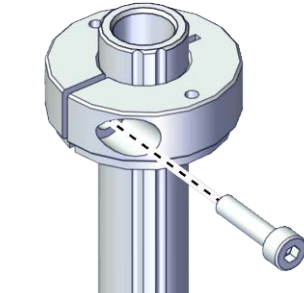

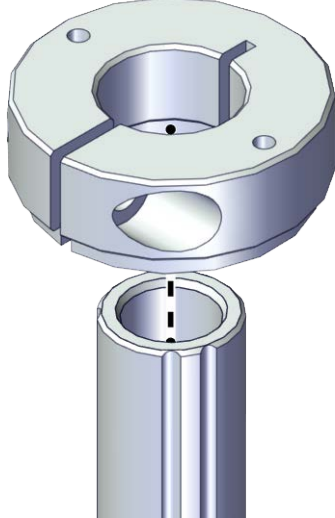
5.6.5 Replacing the ball screw

Continued

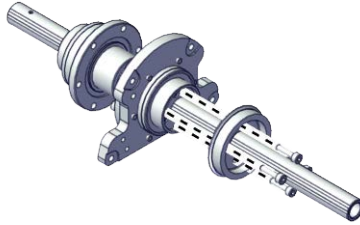

	Action	Note
3	Remove the screw.	<p>For robots with protection class IP30 (option 3350-300)</p>  <p>xx1800002858</p> <p>For robots with protection class IP54 (option 3350-540) For robots with protection type Clean Room (option 3351-1)</p>  <p>xx1900001640</p>
4	<p>Remove the mechanical stopper.</p> <p> Tip</p> <p>Hold the ball screw to prevent it from dropping. Or the ball screw may be destroyed.</p> <p> CAUTION</p> <p>If the ball screw nut or ball screw spline nut go out of the screw shaft, the ball screw is destroyed. Be careful when you do any work that may cause this.</p>	 <p>xx1800002859</p>

Continues on next page

Removing the pulley on the ball screw upper position

	Action	Note
1	 DANGER Make sure that all supplies for electrical power, hydraulic pressure, and air pressure are turned off.	
2	 ELECTROSTATIC DISCHARGE (ESD) The unit is sensitive to ESD. Before handling the unit read the safety information in section The unit is sensitive to ESD on page 45 .	
3	 CAUTION For robots with protection type Clean Room Always cut the paint with a knife and grind the paint edge when disassembling parts of the robot! See Cut the paint or surface on the robot before replacing parts on page 118 .	
4	Remove the screws.	 <small>xx1800003396</small>
5	Remove the pulley carefully.  CAUTION If the ball screw nut or ball screw spline nut go out of the screw shaft, the ball screw is destroyed. Be careful when you do any work that may cause this.	

Removing the adaptor



	Action	Note
1	 DANGER Make sure that all supplies for electrical power, hydraulic pressure, and air pressure are turned off.	
2	 CAUTION For robots with protection type Clean Room Always cut the paint with a knife and grind the paint edge when disassembling parts of the robot! See Cut the paint or surface on the robot before replacing parts on page 118 .	

Continues on next page

5 Repair

5.6.5 Replacing the ball screw

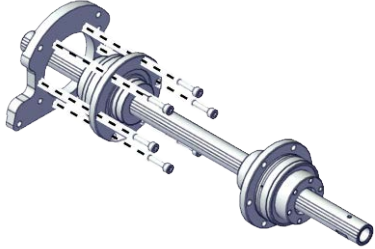

Continued

	Action	Note
3	Remove the screws.	 xx1800003397
4	Remove the adaptor from the ball screw.  CAUTION If the ball screw nut or ball screw spline nut go out of the screw shaft, the ball screw is destroyed. Be careful when you do any work that may cause this.	

Refitting the ball screw

Use these procedures to refit the ball screw.

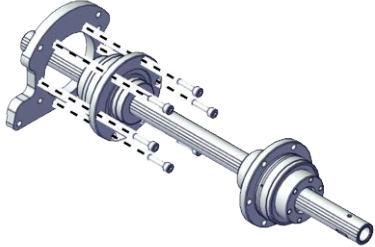

Refitting the adaptor

	Action	Note
1	For robots with protection type Clean Room: Clean the joints that have been opened and wipe the parts free from particles with spirit on a lint free. See Cut the paint or surface on the robot before replacing parts on page 118  Note After all repair work, wipe the Clean Room robot free from particles with spirit on a lint free cloth.	
2	Refit the adaptor to the ball screw.  CAUTION If the ball screw nut or ball screw spline nut go out of the screw shaft, the ball screw is destroyed. Be careful when you do any work that may cause this.	Screws: Hex socket head cap screw M4x16 12.9 Lafre 2C2B/FC6.9 (6 pcs) Tightening torque: 3.8 Nm \pm 10% 
3	Refit the screws.	xx1800003397

Refitting the pulley on the ball screw upper position

	Action	Note
1	 ELECTROSTATIC DISCHARGE (ESD) The unit is sensitive to ESD. Before handling the unit read the safety information in section The unit is sensitive to ESD on page 45 .	

Continues on next page

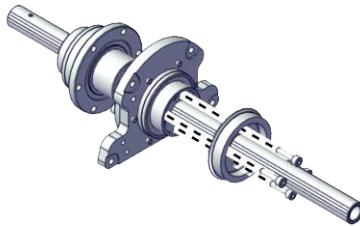
	Action	Note
2	<p>For robots with protection type Clean Room: Clean the joints that have been opened and wipe the parts free from particles with spirit on a lint free. See Cut the paint or surface on the robot before replacing parts on page 118</p> <p> Note</p> <p>After all repair work, wipe the Clean Room robot free from particles with spirit on a lint free cloth.</p>	
3	<p>Refit the pulley to the ball screw carefully.</p> <p> CAUTION</p> <p>If the ball screw nut or ball screw spline nut go out of the screw shaft, the ball screw is destroyed. Be careful when you do any work that may cause this.</p>	<p>For IRB 910INV-3/0.35: Screws: Hex socket head cap screw M4x16 12.9 Lafre 2C2B/FC6.9 (4 pcs) Tightening torque: 2 Nm ±10%</p> <p>For IRB 910INV-6/0.55: Screws: Hex socket head cap screw M5x25 12.9 Lafre 2C2B/FC6.9 (4 pcs) Tightening torque: 5 Nm ±10%</p>
4	<p>Refit the screws.</p> <p> Tip</p> <p>Secure with the special stopping tool to prevent the pulley from rotating.</p>	 <p>xx1800003396</p>



Refitting the upper mechanical stopper

	Action	Note
1	<p>For robots with protection type Clean Room: Clean the joints that have been opened and wipe the parts free from particles with spirit on a lint free. See Cut the paint or surface on the robot before replacing parts on page 118</p> <p> Note</p> <p>After all repair work, wipe the Clean Room robot free from particles with spirit on a lint free cloth.</p>	

5 Repair

5.6.5 Replacing the ball screw

Continued

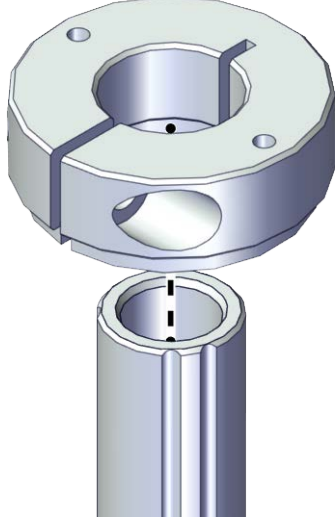
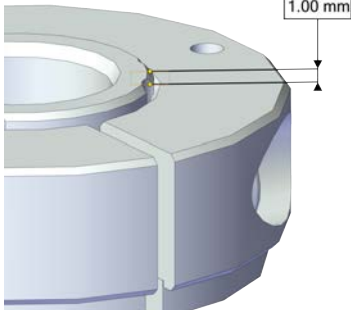
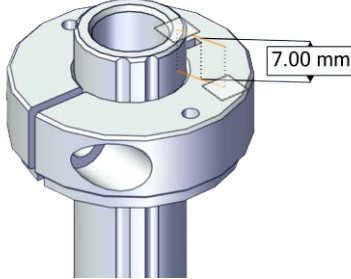
	Action	Note
2	<p>Refit the mechanical stopper to the ball screw at 1 mm position to the upper of the ball screw.</p> <p> Note</p> <p>For robots with protection class IP54 (option 3350-540) For robots with protection type Clean Room (option 3351-1) For IRB 910INV-3/0.35, refit the mechanical stopper to the ball screw at 7 mm position to the upper of the ball screw. For IRB 910INV-6/0.55, refit the mechanical stopper to the ball screw at 2 mm position to the upper of the ball screw.</p> <p> Tip</p> <p>Hold the ball screw to prevent it from dropping. Or the ball screw may be destroyed.</p> <p> CAUTION</p> <p>If the ball screw nut or ball screw spline nut go out of the screw shaft, the ball screw is destroyed. Be careful when you do any work that may cause this.</p>	 <p>xx1800002859</p> <p>For robots with protection class IP30 (option 3350-300)</p>  <p>xx1900002012</p> <p>For robots with protection class IP54 (option 3350-540) For robots with protection type Clean Room (option 3351-1) For IRB 910INV-3/0.35</p>  <p>xx1900001639</p> <p>For IRB 910INV-6/0.55</p>

Continues on next page

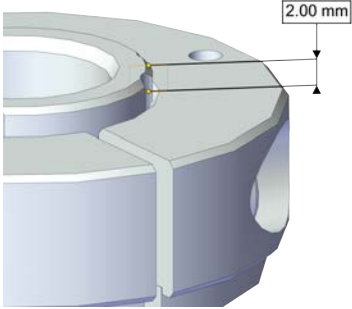
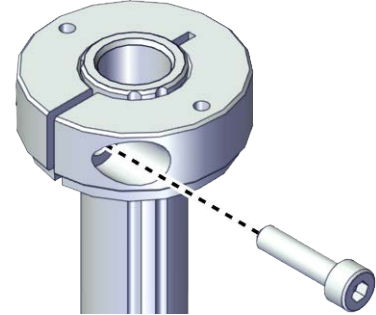
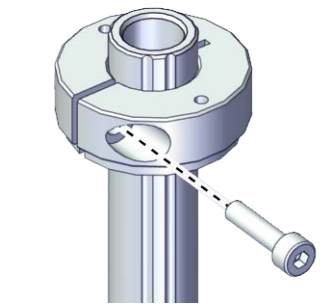
	Action	Note
		 <p>xx1900002011</p>
3	Refit the screw.	<p>Screws: Hex socket head cap screw M4x16 12.9 Lafre 2C2B/FC6.9 (1 pcs) Tightening torque: 6.5 Nm \pm10% For robots with protection class IP30 (option 3350-300)</p>  <p>xx1800002858</p> <p>For robots with protection class IP54 (option 3350-540) For robots with protection type Clean Room (option 3351-1)</p>  <p>xx1900001640</p>

Continues on next page

5 Repair

5.6.5 Replacing the ball screw

Continued

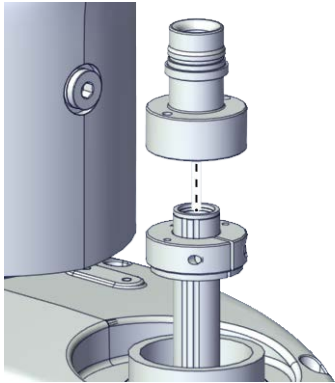
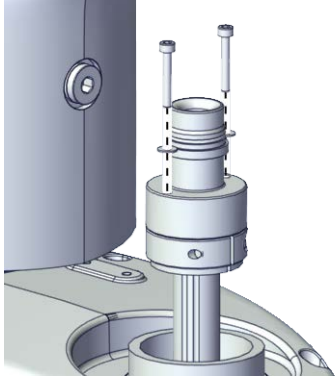

Refitting the extension shaft for Clean Room/ IP54 robots

	Action	Note
1	<p>For robots with protection type Clean Room: Clean the joints that have been opened and wipe the parts free from particles with spirit on a lint free. See Cut the paint or surface on the robot before replacing parts on page 118</p> <p> Note</p> <p>After all repair work, wipe the Clean Room robot free from particles with spirit on a lint free cloth.</p>	
2	<p>For robots with protection class IP54 (option 3350-540) For robots with protection type Clean Room (option 3351-1) Install the extension shaft to the ball screw on the upper side of the mechanical stopper.</p>	 <p>xx1900001558</p>
3	<p>For robots with protection class IP54 (option 3350-540) For robots with protection type Clean Room (option 3351-1) Secure the extension shaft to the mechanical stopper with the screws.</p>	<p>For IRB 910INV-3/0.35: Screws: Hex socket head cap screw M3x20 12.9 Lafre 2C2B/FC6.9 (2 pcs) Tightening torque: 1.2 Nm ±10%</p> <p>For IRB 910INV-6/0.55: Screws: Hex socket head cap screw M3x20 12.9 Lafre 2C2B/FC6.9 (2 pcs) Tightening torque: 1.2 Nm ±10%</p>  <p>xx1900001557</p>

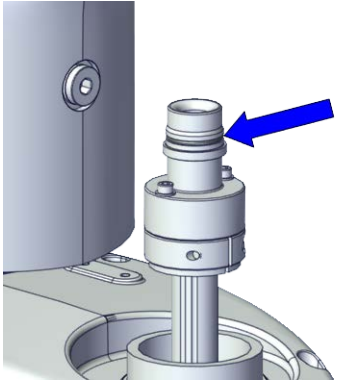
Continues on next page

	Action	Note
4	<p>For robots with protection class IP54 (option 3350-540) For robots with protection type Clean Room (option 3351-1) Insert the O-ring to the extension shaft.</p>	 <p>xx1900001556</p>

Refitting the ball screw assembly

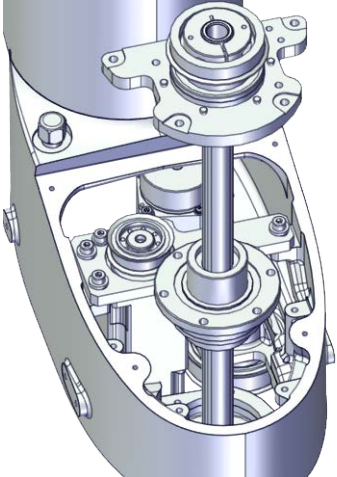

	Action	Note
1	<p>For robots with protection type Clean Room: Clean the joints that have been opened and wipe the parts free from particles with spirit on a lint free. See Cut the paint or surface on the robot before replacing parts on page 118</p> <p> Note</p> <p>After all repair work, wipe the Clean Room robot free from particles with spirit on a lint free cloth.</p>	
2	<p>Refit the ball screw assembly to the outer arm.</p> <p> Tip</p> <p>Hold the lower part of the ball screw to prevent it from dropping. Or the ball screw may be destroyed.</p> <p> CAUTION</p> <p>If the ball screw nut or ball screw spline nut go out of the screw shaft, the ball screw is destroyed. Be careful when you do any work that may cause this.</p>	 <p>xx1800003395</p>

Continues on next page

5 Repair

5.6.5 Replacing the ball screw

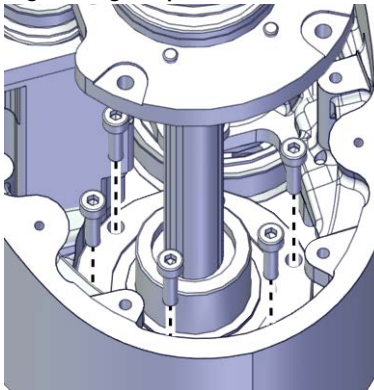

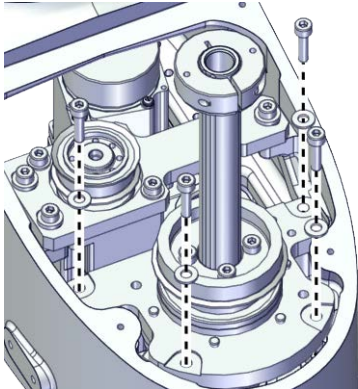
Continued

	Action	Note
3	Refit the screws to secure the lower part of the ball screw to the outer arm.	Screws: Hex socket head cap screw M4x16 12.9 Lafre 2C2B/FC6.9 (6 pcs) Tightening torque: 3.8 Nm \pm 10%  xx1800003394
4	Refit the screws and washers to secure the adaptor on the ball screw to the outer arm.  Tip Pre-tighten the screws at 0.5Nm and slide the ball screw up and down for five times. Then tighten the screws at 3.8Nm to secure it.	Screws: Hex socket head cap screw M4x16 12.9 Lafre 2C2B/FC6.9 (6 pcs) Washers: Spring washer 9x4.3x1 Steel (6 pcs) Tightening torque: 0.5 Nm-3.8 Nm \pm 10%  xx1800003393

Refitting the pulley on the ball screw lower position

	Action	Note
1	 ELECTROSTATIC DISCHARGE (ESD) The unit is sensitive to ESD. Before handling the unit read the safety information in section The unit is sensitive to ESD on page 45 .	

Continues on next page

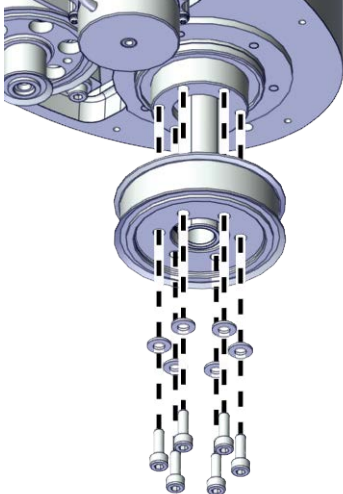
	Action	Note
2	<p>For robots with protection type Clean Room: Clean the joints that have been opened and wipe the parts free from particles with spirit on a lint free. See Cut the paint or surface on the robot before replacing parts on page 118</p> <p> Note</p> <p>After all repair work, wipe the Clean Room robot free from particles with spirit on a lint free cloth.</p>	
3	<p>Refit the pulley to the ball screw carefully.</p> <p> CAUTION</p> <p>If the ball screw nut or ball screw spline nut go out of the screw shaft, the ball screw is destroyed. Be careful when you do any work that may cause this.</p>	<p>For IRB 910INV-3/0.35: Screws: Hex socket head cap screw M4x12 12.9 Lafre 2C2B/FC6.9 (6 pcs) Washers: Spring washer 9x4.3x1 Steel (6 pcs) Tightening torque: 3.8 Nm ±10%</p> <p>For IRB 910INV-6/0.55:</p>
4	<p>Refit the screws.</p> <p> Tip</p> <p>Secure with the special stopping tool to prevent the pulley from rotating.</p>	<p>Screws: Hex socket head cap screw M5x12 12.9 Lafre 2C2B/FC6.9 (6 pcs) Washers: Plain washer 11x5.3x1.2 Steel (6 pcs) Tightening torque: 6.5 Nm ±10%</p>  <p>xx1800002865</p>

Continues on next page

5 Repair





5.6.5 Replacing the ball screw

Continued

Refitting the mechanical stopper

	Action	Note
1	<p>For robots with protection type Clean Room: Clean the joints that have been opened and wipe the parts free from particles with spirit on a lint free. See Cut the paint or surface on the robot before replacing parts on page 118</p> <p> Note</p> <p>After all repair work, wipe the Clean Room robot free from particles with spirit on a lint free cloth.</p>	

Continues on next page

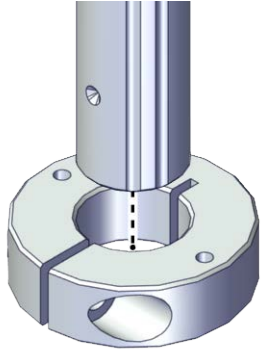
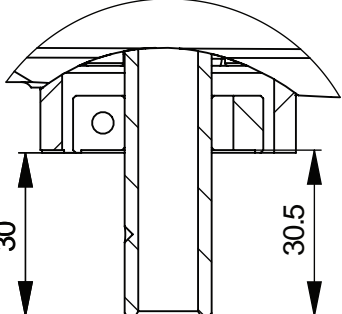
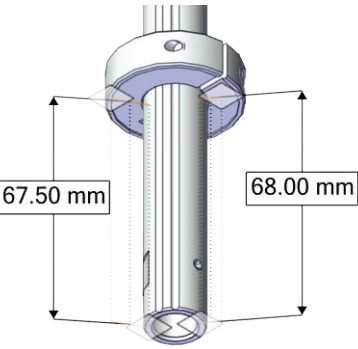
	Action	Note
2	<p>Refit the mechanical stopper to the ball screw at 30.5 mm position to the lower of the ball screw.</p> <p> Note</p> <p>For robots with protection class IP54 (option 3350-540) For robots with protection type Clean Room (option 3351-1) For IRB 910INV-3/0.35, refit the mechanical stopper to the ball screw at 68 mm position to the lower of the ball screw. For IRB 910INV-6/0.55, refit the mechanical stopper to the ball screw at 75.8 mm position to the lower of the ball screw.</p> <p> Tip</p> <p>Make sure that the limit block opening gap is aligned with the ball screw origin point.</p> <p> CAUTION</p> <p>If the ball screw nut or ball screw spline nut go out of the screw shaft, the ball screw is destroyed. Be careful when you do any work that may cause this.</p> <p> Note</p> <p>Be careful with the orientation of the mechanical stopper. The flat side is on the upper side.</p>	 <p>xx1800002861</p> <p>For robots with protection class IP30 (option 3350-300)</p>  <p>xx1900000144</p> <p>For robots with protection class IP54 (option 3350-540) For robots with protection type Clean Room (option 3351-1) For IRB 910INV-3/0.35</p>  <p>xx1900001641</p> <p>For IRB 910INV-6/0.55</p>

Continues on next page

5 Repair

5.6.5 Replacing the ball screw

Continued

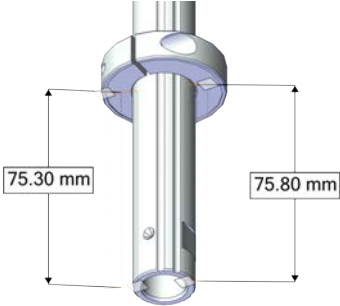
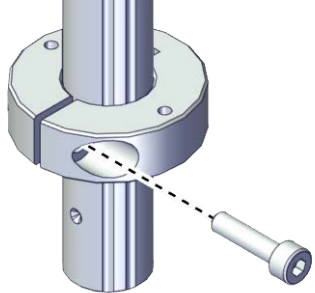
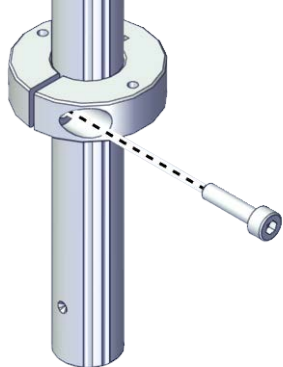
	Action	Note
		 <p data-bbox="1027 636 1139 658">xx1900002004</p>
3	Refit the screw.	<p data-bbox="1027 689 1390 770">Screws: Hex socket head cap screw M4x16 12.9 Lafre 2C2B/FC6.9 (1 pcs)</p> <p data-bbox="1027 779 1390 808">Tightening torque: 6.5 Nm ±10%</p> <p data-bbox="1027 817 1390 869">For robots with protection class IP30 (option 3350-300)</p>  <p data-bbox="1027 1182 1139 1205">xx1800002860</p> <p data-bbox="1027 1227 1390 1279">For robots with protection class IP54 (option 3350-540)</p> <p data-bbox="1027 1288 1390 1339">For robots with protection type Clean Room (option 3351-1)</p>  <p data-bbox="1027 1733 1139 1756">xx1900001642</p>

Continues on next page

Refitting the shaft for Clean Room/ IP54 robots

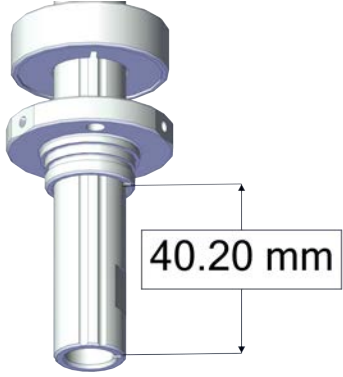
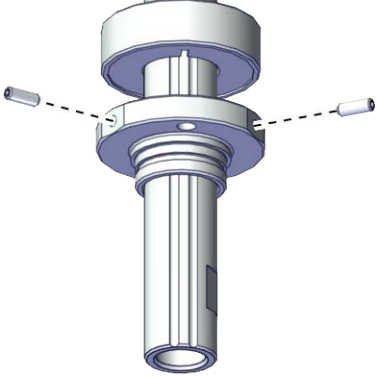
	Action	Note
1	<p>For robots with protection type Clean Room: Clean the joints that have been opened and wipe the parts free from particles with spirit on a lint free. See Cut the paint or surface on the robot before replacing parts on page 118</p> <p> Note</p> <p>After all repair work, wipe the Clean Room robot free from particles with spirit on a lint free cloth.</p>	
2	<p>For robots with protection class IP54 (option 3350-540)</p> <p>For robots with protection type Clean Room (option 3351-1)</p> <p>Install the shaft to the ball screw at 40.2 mm position to the lower of the ball screw.</p>	 <p>xx1900001617</p>
3	<p>For robots with protection class IP54 (option 3350-540)</p> <p>For robots with protection type Clean Room (option 3351-1)</p> <p>Secure the shaft to the ball screw with the screws.</p>	<p>Screws: Hexagon socket set screws with flat point, ISO 4026 stainless steel M3x8 (2 pcs)</p> <p>Tightening torque: 1.2 Nm ±10%</p>  <p>xx1900001616</p>

Continues on next page

5 Repair

5.6.5 Replacing the ball screw

Continued

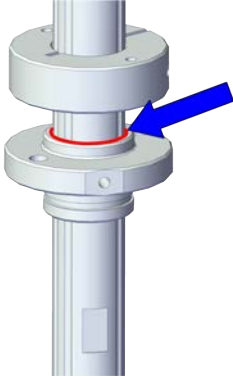
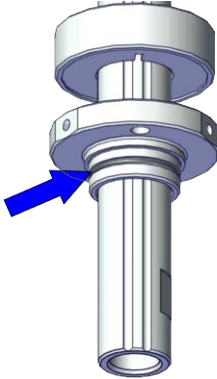
	Action	Note
4	<p>For robots with protection class IP54 (option 3350-540)</p> <p>Apply the glue to the upper contacted zone between the shaft and the ball screw.</p> <p> Note</p> <p>Fulfill the gaps on the ball screw in this contacted zone to make a sealing structure.</p>	 <p>xx1900001805</p>
5	<p>For robots with protection class IP54 (option 3350-540)</p> <p>For robots with protection type Clean Room (option 3351-1)</p> <p>Insert the O-ring to the shaft.</p>	 <p>xx1900001615</p>

Refitting the axis-3 timing belt

	Action	Note
1	<p>For robots with protection type Clean Room:</p> <p>Clean the joints that have been opened and wipe the parts free from particles with spirit on a lint free. See Cut the paint or surface on the robot before replacing parts on page 118</p> <p> Note</p> <p>After all repair work, wipe the Clean Room robot free from particles with spirit on a lint free cloth.</p>	

Continues on next page

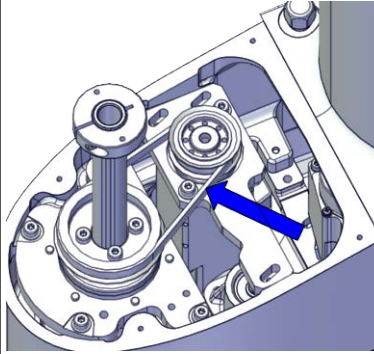
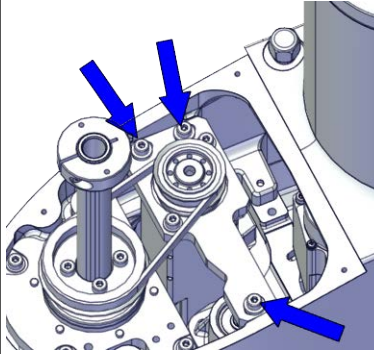
	Action	Note
2	Refit the timing belt to the pulley on the ball screw and the motor. Ensure that the belt runs correctly in the grooves.	Timing belt: 3HAC061862-001  <small>xx1800002886</small>
3	Secure the screws and washers.	Screws: Hex socket head cap screw M4x20 12.9 Lafre 2C2B/FC6.9 (3 pcs) Washers: Washer 4.3x10x2 steel (3 pcs) Tightening torque: 3 Nm ±10%  <small>xx1800002887</small>
4	Use a sonic tension meter to measure the timing belt tension.	Used belt: 190-232Hz New belt: 225-287Hz
5	If the timing belt tension does not meet the requirement, loosen the motor screws and readjust.	

Refitting the axis-4 second timing belt



	Action	Note
1	For robots with protection type Clean Room: Clean the joints that have been opened and wipe the parts free from particles with spirit on a lint free. See Cut the paint or surface on the robot before replacing parts on page 118	
	 Note After all repair work, wipe the Clean Room robot free from particles with spirit on a lint free cloth.	

Continues on next page

5 Repair

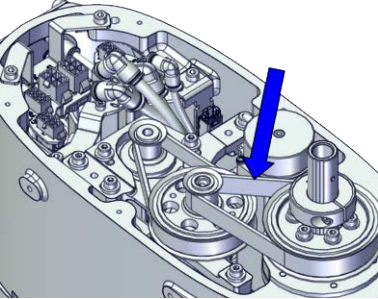

5.6.5 Replacing the ball screw

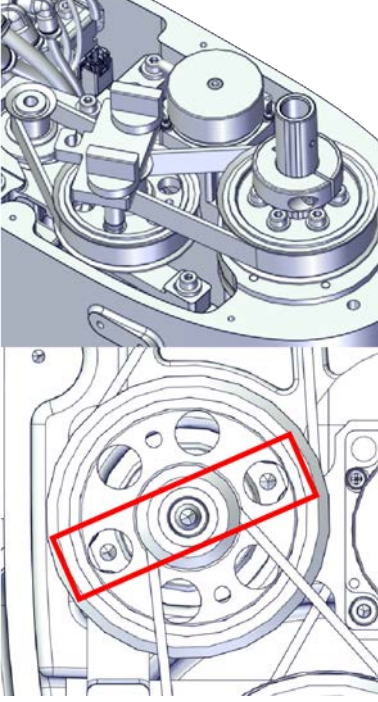
Continued

	Action	Note
2	Refit the timing belt to the pulley and the motor. Ensure that the belt runs correctly in the grooves.	 xx1800002895 Timing belt: 3HAC061864-001
3	Install the axis-4 belt tension adjustment tool to the motor.  Note Just tighten the tool.	Belt tension adjustment tool set, stage two of axis 4:-  xx1900000096

Continues on next page

5.6.5 Replacing the ball screw
Continued

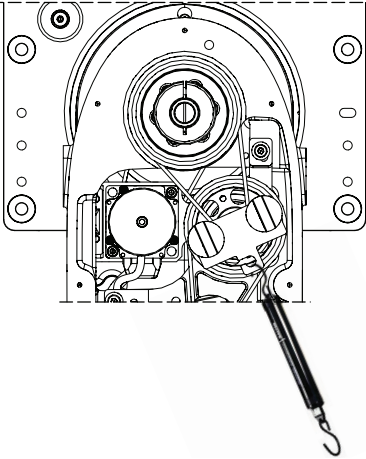
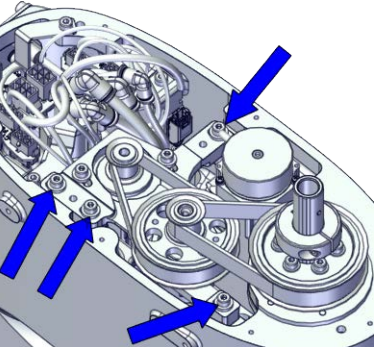
	Action	Note
4	<p>Use a handheld dynamometer hooking to the screw and pull the dynamometer to make the tension falling in the allowed force range.</p> <p> Note</p> <p>During the measurement, make sure that all interferences that may affect the force are removed. Pay attention to the force application direction.</p> <p> Tip</p> <p>If the ball screw will interfere with the handheld dynamometer, adjust the ball screw manually.</p>	<p>Used belt: 84-96N New belt:120-132N</p>  <p>xx190000097</p>
5	<p>Fasten the screws to the recommended tightening torque.</p>	<p>Tightening torque: 3 Nm ±10%</p>  <p>xx1800003389</p>
6	<p>Use a sonic tension meter to measure the timing belt tension.</p>	<p>Used belt: 257-314Hz New belt:304-389Hz</p>
7	<p>If the timing belt tension does not meet the requirement, loosen the motor screws and readjust.</p>	
8	<p>Remove the axis-4 belt tension adjustment tool.</p>	

Refitting the casting cover of the outer arm



	Action	Note
1	<p>For robots with protection type Clean Room: Clean the joints that have been opened and wipe the parts free from particles with spirit on a lint free. See Cut the paint or surface on the robot before replacing parts on page 118</p> <p> Note</p> <p>After all repair work, wipe the Clean Room robot free from particles with spirit on a lint free cloth.</p>	

Continues on next page

5 Repair

5.6.5 Replacing the ball screw

Continued

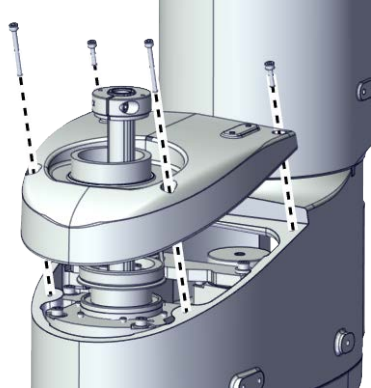
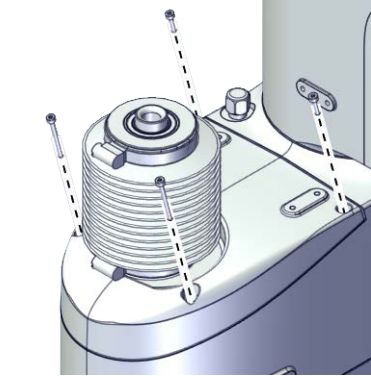
	Action	Note
2	<p>Refit the cover.</p> <p> Note</p> <p>For robots with protection class IP54 (option 3350-540)</p> <p>For robots with protection type Clean Room (option 3351-1)</p> <p>Refit the cover with bellow and housing.</p> <p>Check the gasket on the casting cover.</p> <p> CAUTION</p> <p>There is a gasket in the cover. Be careful when refitting the cover with bellow and housing.</p> <p> Tip</p> <p>Replace the gasket if needed.</p>	<p>Long screw: Hex socket head cap screw M3x30 12.9 Lafre 2C2B/FC6.9 (2 pcs)</p> <p>Tightening torque: 1.2 Nm ±10%</p> <p>Short screw: Hex socket head cap screw M3x12 12.9 Lafre 2C2B/FC6.9 (2 pcs)</p> <p>Tightening torque: 1.2 Nm ±10%</p> <p>For robots with protection class IP30 (option 3350-300)</p>  <p>xx1800002883</p> <p>For robots with protection class IP54 (option 3350-540)</p> <p>For robots with protection type Clean Room (option 3351-1)</p>  <p>xx1900001628</p>
3	<p>Refit the screws.</p>	

Refitting the upper cover

	Action	Note
1	<p>For robots with protection type Clean Room:</p> <p>Clean the joints that have been opened and wipe the parts free from particles with spirit on a lint free. See Cut the paint or surface on the robot before replacing parts on page 118</p> <p> Note</p> <p>After all repair work, wipe the Clean Room robot free from particles with spirit on a lint free cloth.</p>	

Continues on next page

5.6.5 Replacing the ball screw
Continued

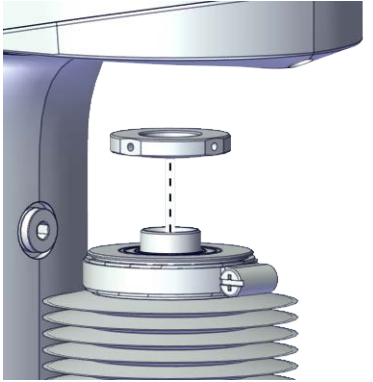
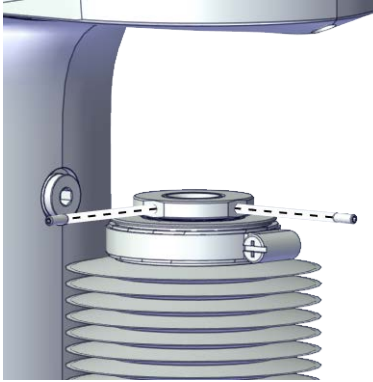
	Action	Note
2	<p>For robots with protection class IP54 (option 3350-540) For robots with protection type Clean Room (option 3351-1) Refit the upper cover to the ball screw.</p>	 <p>xx1900001548</p>
3	<p>For robots with protection class IP54 (option 3350-540) For robots with protection type Clean Room (option 3351-1) Refit the locking screws.</p>	<p>Screws: Hexagon socket set screws with flat point, ISO 4026 stainless steel M3x8 (2 pcs) Tightening torque: 0.6 Nm ±10%</p>  <p>xx1900001547</p>

Refitting the cover of the outer arm



	Action	Note
1	<p>For robots with protection type Clean Room: Clean the joints that have been opened and wipe the parts free from particles with spirit on a lint free. See Cut the paint or surface on the robot before replacing parts on page 118</p> <p> Note After all repair work, wipe the Clean Room robot free from particles with spirit on a lint free cloth.</p>	

Continues on next page

5 Repair

5.6.5 Replacing the ball screw

Continued

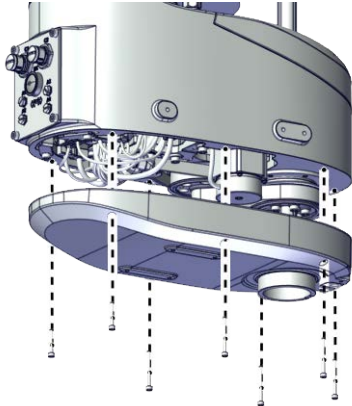
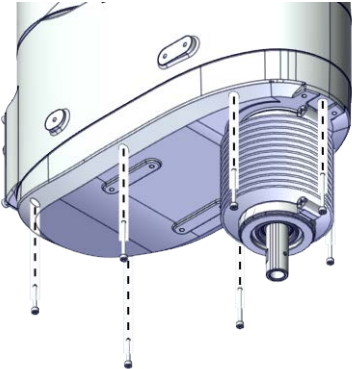
	Action	Note
2	<p>Refit the cover.</p> <p> Note</p> <p>For robots with protection class IP54 (option 3350-540)</p> <p>For robots with protection type Clean Room (option 3351-1)</p> <p>Refit the cover with bellow and housing.</p> <p>Check the gasket on the outer arm cover.</p> <p> Tip</p> <p>Replace the gasket if needed.</p>	<p>For IRB 910INV-3/0.35:</p> <p>Screw: Hex socket head cap screw M3x20 12.9 Lafre 2C2B/FC6.9 (2 pcs)</p> <p>Hex socket head cap screw M3x30 12.9 Lafre 2C2B/FC6.9 (5 pcs)</p> <p>Tightening torque: 1.2 Nm ±10%</p> <p>For IRB 910INV-6/0.55:</p> <p>Screw: Hex socket head cap screw M3x20 12.9 Lafre 2C2B/FC6.9 (2 pcs)</p> <p>Hex socket head cap screw M3x30 12.9 Lafre 2C2B/FC6.9 (7 pcs)</p> <p>Tightening torque: 1.2 Nm ±10%</p> <p>For robots with protection class IP30 (option 3350-300)</p>
3	<p>Refit the screws.</p>	 <p>xx1800002836</p> <p>For robots with protection class IP54 (option 3350-540)</p> <p>For robots with protection type Clean Room (option 3351-1)</p>  <p>xx1900001631</p>

Continues on next page

Refitting the lower cover

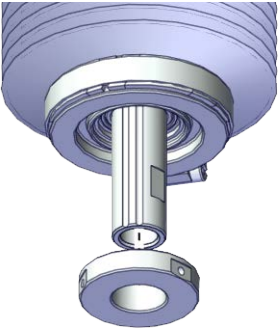
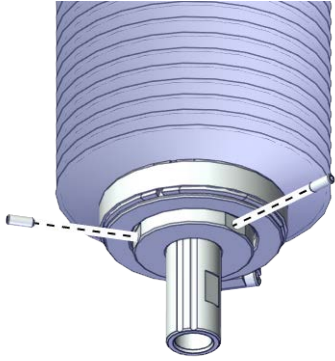
	Action	Note
1	<p>For robots with protection type Clean Room: Clean the joints that have been opened and wipe the parts free from particles with spirit on a lint free. See Cut the paint or surface on the robot before replacing parts on page 118</p> <p> Note</p> <p>After all repair work, wipe the Clean Room robot free from particles with spirit on a lint free cloth.</p>	
2	<p>For robots with protection class IP54 (option 3350-540) For robots with protection type Clean Room (option 3351-1) Refit the lower cover to the ball screw.</p>	 <p>xx1900001607</p>
3	<p>For robots with protection class IP54 (option 3350-540) For robots with protection type Clean Room (option 3351-1) Refit the locking screws.</p>	<p>Screws: Hexagon socket set screws with flat point, ISO 4026 stainless steel M3x8 (2 pcs) Tightening torque: 0.6 Nm ±10%</p>  <p>xx1900001606</p>



Continues on next page

5 Repair

5.6.5 Replacing the ball screw

Continued

Concluding procedure

	Action	Note
1	<p>For robots with protection type Clean Room: Seal and paint the joints that have been opened. See Cut the paint or surface on the robot before replacing parts on page 118</p> <p> Note</p> <p>After all repair work, wipe the Clean Room robot free from particles with spirit on a lint free cloth.</p>	
2	Recalibrate the robot.	Calibration is detailed in section Calibration on page 771 .
3	<p> DANGER</p> <p>Make sure all safety requirements are met when performing the first test run. See Test run after installation, maintenance, or repair on page 56.</p>	

5.6.6 Replacing the axis-3 timing belt

Location of the axis-3 timing belt

The axis-3 timing belt is located as shown in the figure.

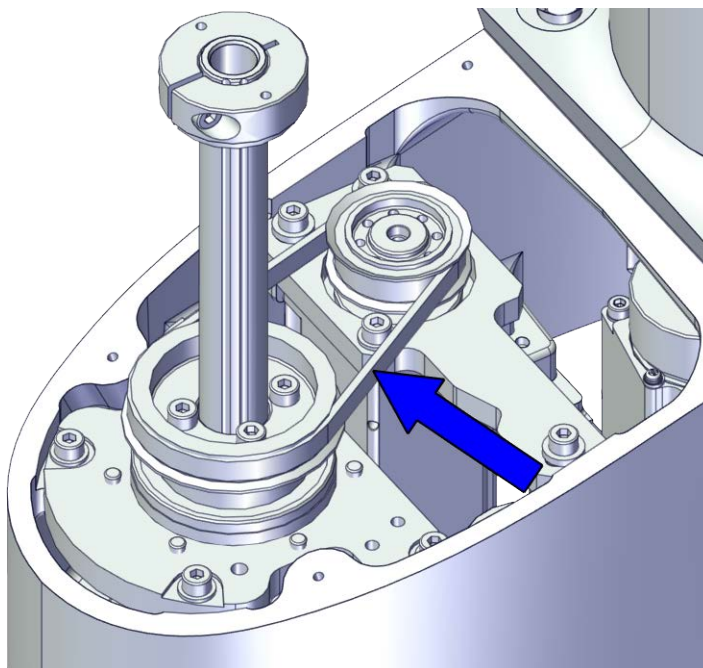

xx1800003400

Required spare parts



Note

The spare part numbers that are listed in the table can be out of date. See the latest spare parts of the IRB 910INV via myABB Business Portal, www.abb.com/myABB.

Spare part	Article number	Note
Timing belt	3HAC061862-001	

Required tools and equipment

Equipment	Article number	Note
Standard toolkit	-	Content is defined in section Standard toolkit on page 840 .
Calibration tool box, Axis Calibration	3HAC074119-001	Delivered as a set of calibration tools. Required if Axis Calibration is the valid calibration method for the robot. ⁱ
24 VDC power supply	-	Used to release the motor brakes.

Continues on next page

5 Repair

5.6.6 Replacing the axis-3 timing belt

Continued

Equipment	Article number	Note
Sonic tension meter	-	Used for measuring the timing belt tension.

- i The robot is calibrated by either manual calibration or Axis Calibration at ABB factory before delivery. Always use the same calibration method as used at the factory.
Information about valid calibration method is found on the calibration label or in the calibration menu on the FlexPendant.
If no data is found related to standard calibration, manual calibration is used as default.

Required consumables

Consumable	Article number	Note
Cable straps	-	

Deciding calibration routine

Decide which calibration routine to be used, based on the information in the table. Depending on which routine is chosen, action might be required prior to beginning the repair work of the robot, see the table.

	Action	Note
1	Decide which calibration routine to use for calibrating the robot. <ul style="list-style-type: none"> Reference calibration. External cable packages (DressPack) and tools can stay fitted on the robot. Fine calibration. All external cable packages (DressPack) and tools must be removed from the robot. 	
	If the robot is to be calibrated with reference calibration: Find previous reference values for the axis or create new reference values. These values are to be used after the repair procedure is completed, for calibration of the robot. If no previous reference values exist, and no new reference values can be created, then reference calibration is not possible.	Follow the instructions given in the reference calibration routine on the FlexPendant to create reference values. Creating new values requires possibility to move the robot. Read more about reference calibration for Axis Calibration in Reference calibration routine on page 798 .
	If the robot is to be calibrated with fine calibration: Remove all external cable packages (DressPack) and tools from the robot.	



Removing the axis-3 timing belt

Use these procedures to remove the axis-3 timing belt.

Preparations before removing the axis-3 timing belt

	Action	Note
1	Decide which calibration routine to use, and take actions accordingly prior to beginning the repair procedure.	

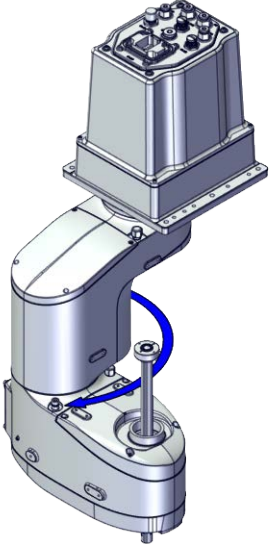
Continues on next page

	Action	Note
2	<p>If there is no enough space for the maintenance work, remove the robot from the wall and place it on the maintenance bracket.</p> <p> CAUTION</p> <p>Do not lay down the robot during the transportation, always keep it straight. If the robot lay down in any situation, the grease may come out from gearbox.</p>	
3	<p>Jog the outer arm to access the casting cover screws.</p>	 <p>xx1800003407</p>
4	<p> DANGER</p> <p>Turn off all:</p> <ul style="list-style-type: none"> • electric power supply • hydraulic pressure supply • air pressure supply <p>to the robot, before entering the safeguarded space.</p>	
5	<p> CAUTION</p> <p>For robots with protection type Clean Room Always cut the paint with a knife and grind the paint edge when disassembling parts of the robot! See Cut the paint or surface on the robot before replacing parts on page 118.</p>	



Continues on next page

5 Repair

5.6.6 Replacing the axis-3 timing belt

Continued



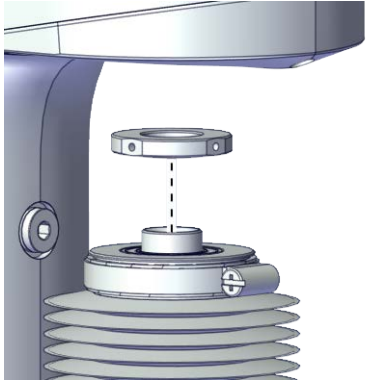

Removing the upper cover

	Action	Note
1	 DANGER Make sure that all supplies for electrical power, hydraulic pressure, and air pressure are turned off.	
2	 CAUTION For robots with protection type Clean Room Always cut the paint with a knife and grind the paint edge when disassembling parts of the robot! See Cut the paint or surface on the robot before replacing parts on page 118 .	
3	For robots with protection class IP54 (option 3350-540) For robots with protection type Clean Room (option 3351-1) Loose the locking screws.	 <small>xx1900001547</small>
4	For robots with protection class IP54 (option 3350-540) For robots with protection type Clean Room (option 3351-1) Remove the upper cover from the ball screw.	 <small>xx1900001548</small>

Removing the casting cover of the outer arm

	Action	Note
1	 DANGER Make sure that all supplies for electrical power, hydraulic pressure, and air pressure are turned off.	

Continues on next page

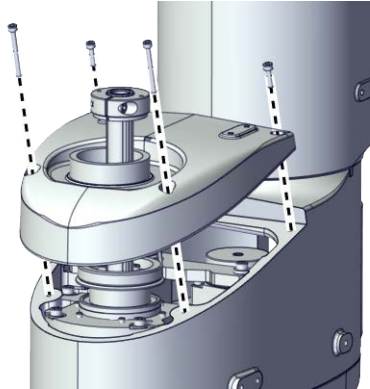
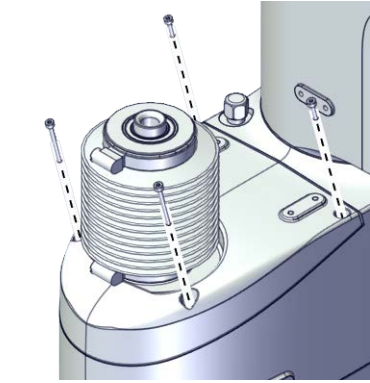
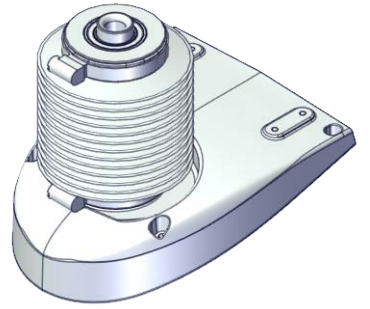
	Action	Note
2	<p> CAUTION</p> <p>For robots with protection type Clean Room Always cut the paint with a knife and grind the paint edge when disassembling parts of the robot! See <i>Cut the paint or surface on the robot before replacing parts on page 118.</i></p>	
3	<p>Remove the screws on the casting cover of the outer arm and remove the cover.</p> <p> Note</p> <p>For robots with protection class IP54 (option 3350-540) For robots with protection type Clean Room (option 3351-1) Remove the cover with bellow and housing.</p> <p> Note</p> <p>The bellow does not need to be removed separately.</p> <p> CAUTION</p> <p>There is a gasket in the cover. Be careful when removing the cover with bellow and housing.</p> <p> Tip</p> <p>Check the gasket and replace it if needed.</p>	<p>For robots with protection class IP30 (option 3350-300)</p>  <p>xx1800002883</p> <p>For robots with protection class IP54 (option 3350-540) For robots with protection type Clean Room (option 3351-1)</p>  <p>xx1900001628</p>  <p>xx1900001629</p>



Continues on next page

5 Repair

5.6.6 Replacing the axis-3 timing belt

Continued

Removing the axis-3 timing belt

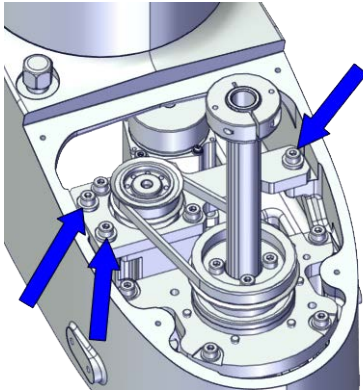
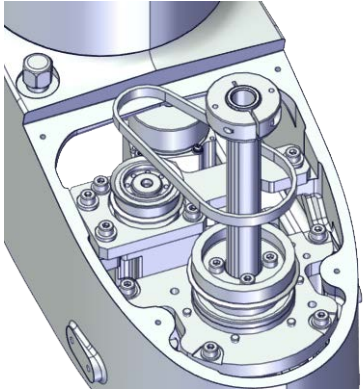
	Action	Note
1	 DANGER Make sure that all supplies for electrical power, hydraulic pressure, and air pressure are turned off.	
2	 CAUTION For robots with protection type Clean Room Always cut the paint with a knife and grind the paint edge when disassembling parts of the robot! See Cut the paint or surface on the robot before replacing parts on page 118 .	
3	 DANGER Make sure that the ball screw is supported with something. The sudden drop of the ball screw due the lost of the axis-3 motor may cause danger.	
4	Loosen the screws of the axis-3 motor sub-assembly to let the axis-3 timing belt free.	 xx1800003391
5	Remove the timing belt.	 xx1800003392

Continues on next page

Refitting the axis-3 timing belt

Use these procedures to refit the axis-3 timing belt.

Refitting the axis-3 timing belt

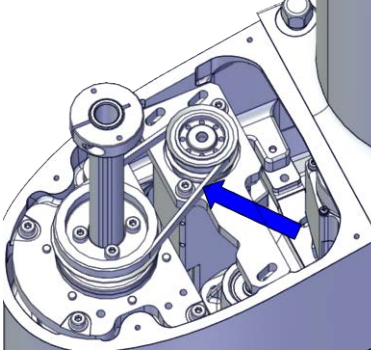
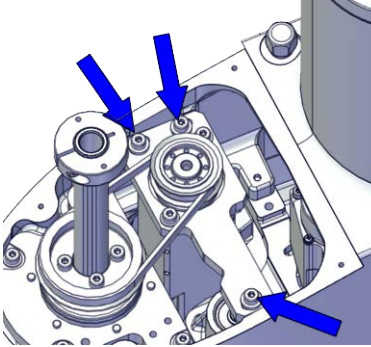
	Action	Note
1	<p>For robots with protection type Clean Room: Clean the joints that have been opened and wipe the parts free from particles with spirit on a lint free. See Cut the paint or surface on the robot before replacing parts on page 118</p> <p> Note</p> <p>After all repair work, wipe the Clean Room robot free from particles with spirit on a lint free cloth.</p>	
2	<p>Refit the timing belt to the pulley on the ball screw and the motor. Ensure that the belt runs correctly in the grooves.</p>	<p>Timing belt: 3HAC061862-001</p>  <p>xx1800002886</p>
3	<p>Secure the screws and washers.</p>	<p>Screws: Hex socket head cap screw M4x20 12.9 Lafre 2C2B/FC6.9 (3 pcs) Washers: Washer 4.3x10x2 steel (3 pcs) Tightening torque: 3 Nm ±10%</p>  <p>xx1800002887</p>
4	<p>Use a sonic tension meter to measure the timing belt tension.</p>	<p>Used belt: 190-232Hz New belt: 225-287Hz</p>
5	<p>If the timing belt tension does not meet the requirement, loosen the motor screws and readjust.</p>	





Continues on next page

5 Repair

5.6.6 Replacing the axis-3 timing belt

Continued

Refitting the casting cover of the outer arm

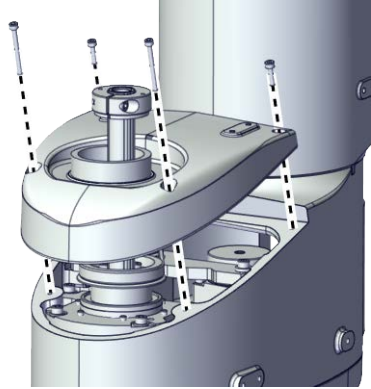
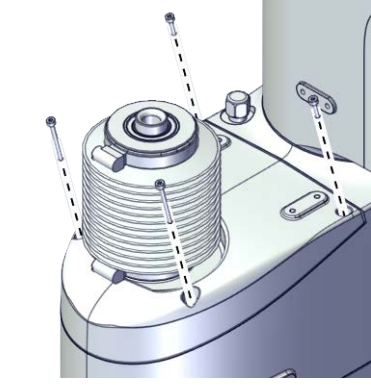
	Action	Note
1	<p>For robots with protection type Clean Room: Clean the joints that have been opened and wipe the parts free from particles with spirit on a lint free. See Cut the paint or surface on the robot before replacing parts on page 118</p> <p> Note</p> <p>After all repair work, wipe the Clean Room robot free from particles with spirit on a lint free cloth.</p>	
2	<p>Refit the cover.</p> <p> Note</p> <p>For robots with protection class IP54 (option 3350-540) For robots with protection type Clean Room (option 3351-1)</p> <p>Refit the cover with bellow and housing. Check the gasket on the casting cover.</p> <p> CAUTION</p> <p>There is a gasket in the cover. Be careful when refitting the cover with bellow and housing.</p> <p> Tip</p> <p>Replace the gasket if needed.</p>	<p>Long screw: Hex socket head cap screw M3x30 12.9 Lafre 2C2B/FC6.9 (2 pcs) Tightening torque: 1.2 Nm ±10%</p> <p>Short screw: Hex socket head cap screw M3x12 12.9 Lafre 2C2B/FC6.9 (2 pcs) Tightening torque: 1.2 Nm ±10%</p> <p>For robots with protection class IP30 (option 3350-300)</p>  <p>xx1800002883</p>
3	<p>Refit the screws.</p>	<p>For robots with protection class IP54 (option 3350-540) For robots with protection type Clean Room (option 3351-1)</p>  <p>xx1900001628</p>

Continues on next page

Refitting the upper cover

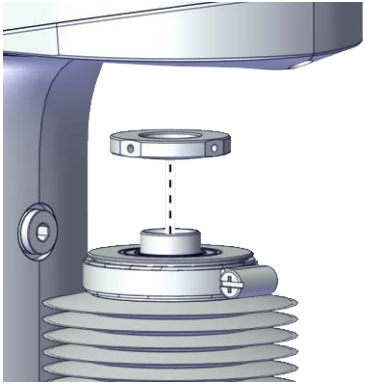
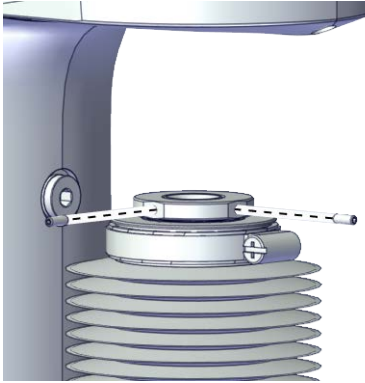
	Action	Note
1	<p>For robots with protection type Clean Room: Clean the joints that have been opened and wipe the parts free from particles with spirit on a lint free. See Cut the paint or surface on the robot before replacing parts on page 118</p> <p> Note</p> <p>After all repair work, wipe the Clean Room robot free from particles with spirit on a lint free cloth.</p>	
2	<p>For robots with protection class IP54 (option 3350-540) For robots with protection type Clean Room (option 3351-1) Refit the upper cover to the ball screw.</p>	 <p>xx1900001548</p>
3	<p>For robots with protection class IP54 (option 3350-540) For robots with protection type Clean Room (option 3351-1) Refit the locking screws.</p>	<p>Screws: Hexagon socket set screws with flat point, ISO 4026 stainless steel M3x8 (2 pcs) Tightening torque: 0.6 Nm ±10%</p>  <p>xx1900001547</p>



Continues on next page

5 Repair

5.6.6 Replacing the axis-3 timing belt

Continued

Concluding procedure

	Action	Note
1	<p>For robots with protection type Clean Room: Seal and paint the joints that have been opened. See Cut the paint or surface on the robot before replacing parts on page 118</p> <p> Note</p> <p>After all repair work, wipe the Clean Room robot free from particles with spirit on a lint free cloth.</p>	
2	Recalibrate the robot.	Calibration is detailed in section Calibration on page 771 .
3	<p> DANGER</p> <p>Make sure all safety requirements are met when performing the first test run. See Test run after installation, maintenance, or repair on page 56.</p>	

5.6.7 Replacing the axis-4 second timing belt

Location of the axis-4 second timing belt

The axis-4 second timing belt is located as shown in the figure.

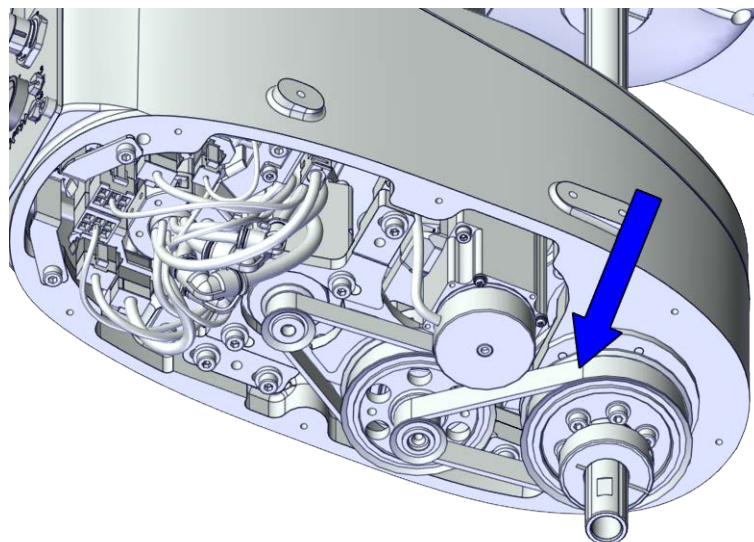

xx1800003402

Required spare parts



Note

The spare part numbers that are listed in the table can be out of date. See the latest spare parts of the IRB 910INV via myABB Business Portal, www.abb.com/myABB.

Spare part	Article number	Note
Timing belt	3HAC061864-001	

Required tools and equipment

Equipment	Article number	Note
Standard toolkit	-	Content is defined in section Standard toolkit on page 840 .
Calibration tool box, Axis Calibration	3HAC074119-001	Delivered as a set of calibration tools. Required if Axis Calibration is the valid calibration method for the robot. ⁱ
24 VDC power supply	-	Used to release the motor brakes.
Belt tension adjustment tool set, stage two of axis 4	-	Included in the special toolkit 3HAC073070-001. Used to adjust the tension of axis-4 timing belt. Special tool for L2

Continues on next page

5 Repair

5.6.7 Replacing the axis-4 second timing belt

Continued

Equipment	Article number	Note
Sonic tension meter	-	Used for measuring the timing belt tension.
Handheld dynamometer	-	Used for measuring the timing belt tension.

- i The robot is calibrated by either manual calibration or Axis Calibration at ABB factory before delivery. Always use the same calibration method as used at the factory.
Information about valid calibration method is found on the calibration label or in the calibration menu on the FlexPendant.
If no data is found related to standard calibration, manual calibration is used as default.

Required consumables

Consumable	Article number	Note
Cable straps	-	

Deciding calibration routine

Decide which calibration routine to be used, based on the information in the table. Depending on which routine is chosen, action might be required prior to beginning the repair work of the robot, see the table.

	Action	Note
1	Decide which calibration routine to use for calibrating the robot. <ul style="list-style-type: none"> Reference calibration. External cable packages (DressPack) and tools can stay fitted on the robot. Fine calibration. All external cable packages (DressPack) and tools must be removed from the robot. 	
	If the robot is to be calibrated with reference calibration: Find previous reference values for the axis or create new reference values. These values are to be used after the repair procedure is completed, for calibration of the robot. If no previous reference values exist, and no new reference values can be created, then reference calibration is not possible.	Follow the instructions given in the reference calibration routine on the FlexPendant to create reference values. Creating new values requires possibility to move the robot. Read more about reference calibration for Axis Calibration in Reference calibration routine on page 798 .
	If the robot is to be calibrated with fine calibration: Remove all external cable packages (DressPack) and tools from the robot.	



Removing the axis-4 second timing belt

Use these procedures to remove the axis-4 second timing belt.

Preparations before removing the axis-4 second timing belt

	Action	Note
1	Decide which calibration routine to use, and take actions accordingly prior to beginning the repair procedure.	

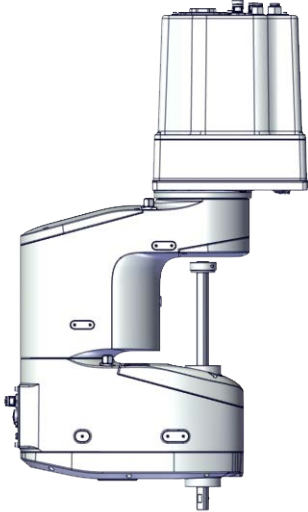
Continues on next page

	Action	Note
2	<p>If there is no enough space for the maintenance work, remove the robot from the wall and place it on the maintenance bracket.</p> <p> CAUTION</p> <p>Do not lay down the robot during the transportation, always keep it straight. If the robot lay down in any situation, the grease may come out from gearbox.</p>	
3	<p>Jog all axes to zero position.</p>	 <p>xx1800002825</p>
4	<p> DANGER</p> <p>Turn off all:</p> <ul style="list-style-type: none"> • electric power supply • hydraulic pressure supply • air pressure supply <p>to the robot, before entering the safeguarded space.</p>	
5	<p> CAUTION</p> <p>For robots with protection type Clean Room Always cut the paint with a knife and grind the paint edge when disassembling parts of the robot! See <i>Cut the paint or surface on the robot before replacing parts on page 118.</i></p>	



Continues on next page

5 Repair

5.6.7 Replacing the axis-4 second timing belt

Continued



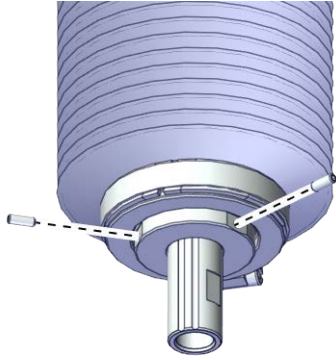
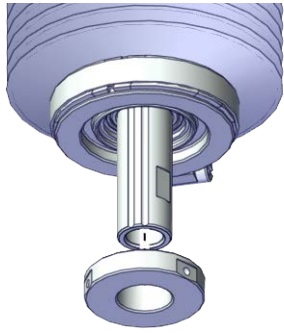

Removing the lower cover

	Action	Note
1	 DANGER Make sure that all supplies for electrical power, hydraulic pressure, and air pressure are turned off.	
2	 CAUTION For robots with protection type Clean Room Always cut the paint with a knife and grind the paint edge when disassembling parts of the robot! See Cut the paint or surface on the robot before replacing parts on page 118 .	
3	For robots with protection class IP54 (option 3350-540) For robots with protection type Clean Room (option 3351-1) Loose the locking screws.	 <small>xx1900001606</small>
4	For robots with protection class IP54 (option 3350-540) For robots with protection type Clean Room (option 3351-1) Remove the lower cover from the ball screw.	 <small>xx1900001607</small>

Removing the cover of the outer arm

	Action	Note
1	 DANGER Make sure that all supplies for electrical power, hydraulic pressure, and air pressure are turned off.	

Continues on next page

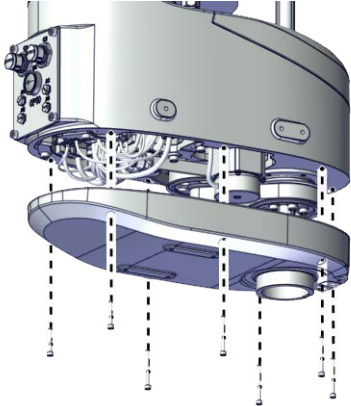
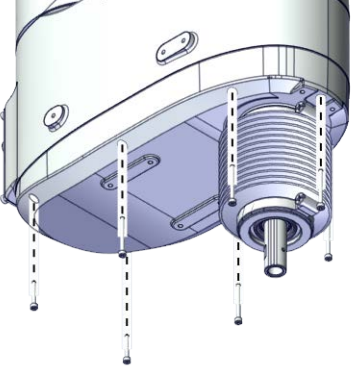
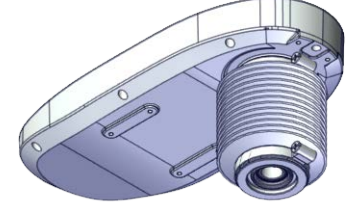
	Action	Note
2	<p> CAUTION</p> <p>For robots with protection type Clean Room Always cut the paint with a knife and grind the paint edge when disassembling parts of the robot! See <i>Cut the paint or surface on the robot before replacing parts on page 118.</i></p>	
3	<p>Remove the screws on the cover of the outer arm and remove the cover.</p> <p> Note</p> <p>For robots with protection class IP54 (option 3350-540) For robots with protection type Clean Room (option 3351-1) Remove the cover with bellow and housing.</p> <p> Note</p> <p>The bellow does not need to be removed separately.</p> <p> CAUTION</p> <p>There is a gasket in the cover. Be careful when removing the cover with bellow and housing.</p> <p> Tip</p> <p>Check the gasket and replace it if needed.</p>	<p>For robots with protection class IP30 (option 3350-300)</p>  <p>xx1800002836</p> <p>For robots with protection class IP54 (option 3350-540) For robots with protection type Clean Room (option 3351-1)</p>  <p>xx1900001631</p>  <p>xx1900001632</p>



Continues on next page

5 Repair

5.6.7 Replacing the axis-4 second timing belt

Continued

Removing the axis-4 second timing belt

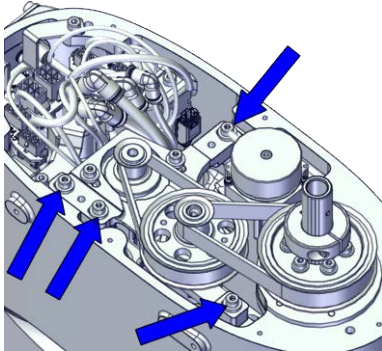
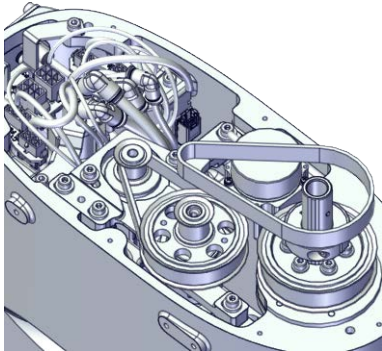
	Action	Note
1	 DANGER Make sure that all supplies for electrical power, hydraulic pressure, and air pressure are turned off.	
2	 CAUTION For robots with protection type Clean Room Always cut the paint with a knife and grind the paint edge when disassembling parts of the robot! See Cut the paint or surface on the robot before replacing parts on page 118 .	
3	Loosen the screws of the pulley pre-assembly to let the axis-4 second timing belt be free.	 xx1800003389
4	Remove the timing belt.	 xx1800003390

Continues on next page

Refitting the axis-4 second timing belt

Use these procedures to refit the axis-4 second timing belt.

Refitting the axis-4 second timing belt

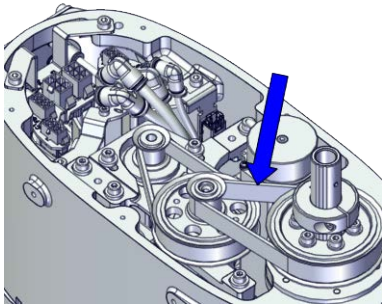

	Action	Note
1	<p>For robots with protection type Clean Room: Clean the joints that have been opened and wipe the parts free from particles with spirit on a lint free. See Cut the paint or surface on the robot before replacing parts on page 118</p> <p> Note</p> <p>After all repair work, wipe the Clean Room robot free from particles with spirit on a lint free cloth.</p>	
2	<p>Refit the timing belt to the pulley and the motor. Ensure that the belt runs correctly in the grooves.</p>	 <p>xx1800002895</p> <p>Timing belt: 3HAC061864-001</p>

Continues on next page

5 Repair

5.6.7 Replacing the axis-4 second timing belt

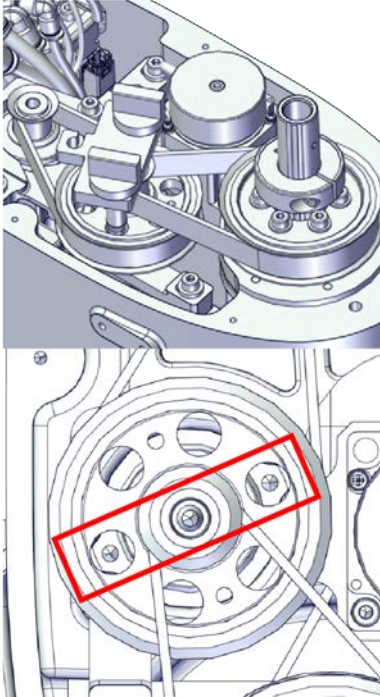
Continued

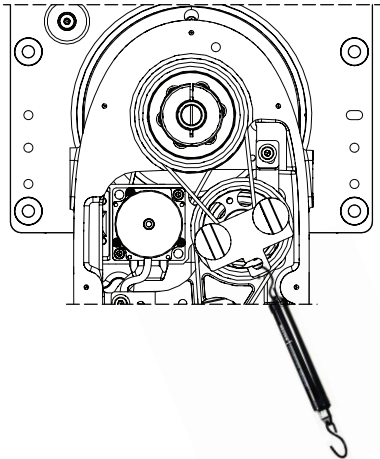
	Action	Note
3	<p>Install the axis-4 belt tension adjustment tool to the motor.</p> <p> Note</p> <p>Just tighten the tool.</p>	<p>Belt tension adjustment tool set, stage two of axis 4:-</p>  <p>xx1900000096</p>
4	<p>Use a handheld dynamometer hooking to the screw and pull the dynamometer to make the tension falling in the allowed force range.</p> <p> Note</p> <p>During the measurement, make sure that all interferences that may affect the force are removed. Pay attention to the force application direction.</p> <p> Tip</p> <p>If the ball screw will interfere with the handheld dynamometer, adjust the ball screw manually.</p>	<p>Used belt: 84-96N New belt:120-132N</p>  <p>xx1900000097</p>

Continues on next page

5.6.7 Replacing the axis-4 second timing belt

Continued

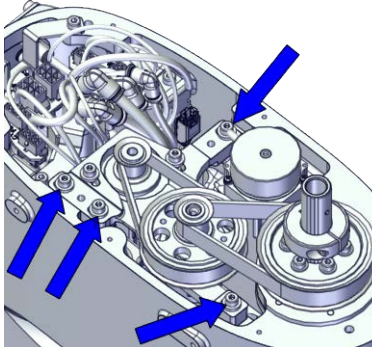
	Action	Note
5	Fasten the screws to the recommended tightening torque.	<p>Tightening torque: 3 Nm \pm10%</p>  <p>xx1800003389</p>
6	Use a sonic tension meter to measure the timing belt tension.	<p>Used belt: 257-314Hz New belt:304-389Hz</p>
7	If the timing belt tension does not meet the requirement, loosen the motor screws and readjust.	
8	Remove the axis-4 belt tension adjustment tool.	

Refitting the cover of the outer arm



	Action	Note
1	<p>For robots with protection type Clean Room: Clean the joints that have been opened and wipe the parts free from particles with spirit on a lint free. See Cut the paint or surface on the robot before replacing parts on page 118</p> <p> Note</p> <p>After all repair work, wipe the Clean Room robot free from particles with spirit on a lint free cloth.</p>	

Continues on next page

5 Repair

5.6.7 Replacing the axis-4 second timing belt

Continued

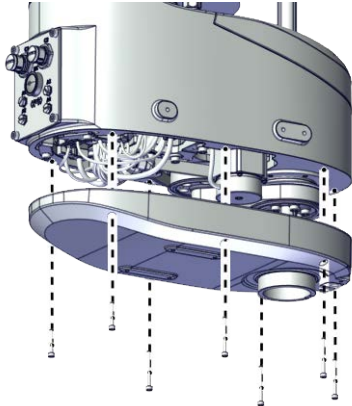
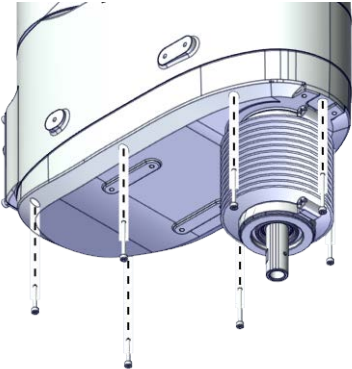
	Action	Note
2	<p>Refit the cover.</p> <p> Note</p> <p>For robots with protection class IP54 (option 3350-540)</p> <p>For robots with protection type Clean Room (option 3351-1)</p> <p>Refit the cover with bellow and housing.</p> <p>Check the gasket on the outer arm cover.</p> <p> Tip</p> <p>Replace the gasket if needed.</p>	<p>For IRB 910INV-3/0.35:</p> <p>Screw: Hex socket head cap screw M3x20 12.9 Lafre 2C2B/FC6.9 (2 pcs)</p> <p>Hex socket head cap screw M3x30 12.9 Lafre 2C2B/FC6.9 (5 pcs)</p> <p>Tightening torque: 1.2 Nm ±10%</p> <p>For IRB 910INV-6/0.55:</p> <p>Screw: Hex socket head cap screw M3x20 12.9 Lafre 2C2B/FC6.9 (2 pcs)</p> <p>Hex socket head cap screw M3x30 12.9 Lafre 2C2B/FC6.9 (7 pcs)</p> <p>Tightening torque: 1.2 Nm ±10%</p> <p>For robots with protection class IP30 (option 3350-300)</p>
3	<p>Refit the screws.</p>	 <p>xx1800002836</p> <p>For robots with protection class IP54 (option 3350-540)</p> <p>For robots with protection type Clean Room (option 3351-1)</p>  <p>xx1900001631</p>

Continues on next page

Refitting the lower cover

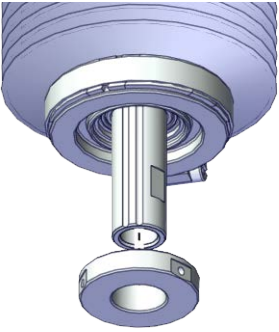
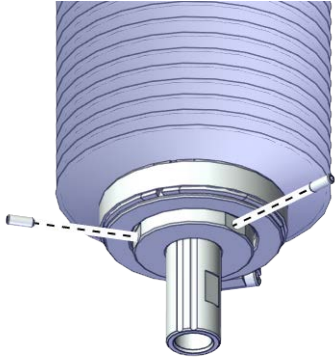
	Action	Note
1	<p>For robots with protection type Clean Room: Clean the joints that have been opened and wipe the parts free from particles with spirit on a lint free. See Cut the paint or surface on the robot before replacing parts on page 118</p> <p> Note</p> <p>After all repair work, wipe the Clean Room robot free from particles with spirit on a lint free cloth.</p>	
2	<p>For robots with protection class IP54 (option 3350-540) For robots with protection type Clean Room (option 3351-1) Refit the lower cover to the ball screw.</p>	 <p>xx1900001607</p>
3	<p>For robots with protection class IP54 (option 3350-540) For robots with protection type Clean Room (option 3351-1) Refit the locking screws.</p>	<p>Screws: Hexagon socket set screws with flat point, ISO 4026 stainless steel M3x8 (2 pcs) Tightening torque: 0.6 Nm ±10%</p>  <p>xx1900001606</p>



Continues on next page

5 Repair

5.6.7 Replacing the axis-4 second timing belt

Continued

Concluding procedure

	Action	Note
1	<p>For robots with protection type Clean Room: Seal and paint the joints that have been opened. See Cut the paint or surface on the robot before replacing parts on page 118</p> <p> Note</p> <p>After all repair work, wipe the Clean Room robot free from particles with spirit on a lint free cloth.</p>	
2	Recalibrate the robot.	Calibration is detailed in section Calibration on page 771 .
3	<p> DANGER</p> <p>Make sure all safety requirements are met when performing the first test run. See Test run after installation, maintenance, or repair on page 56.</p>	

5.6.8 Replacing the axis-4 timing belt

Location of the axis-4 timing belt

The axis-4 timing belt is located as shown in the figure.

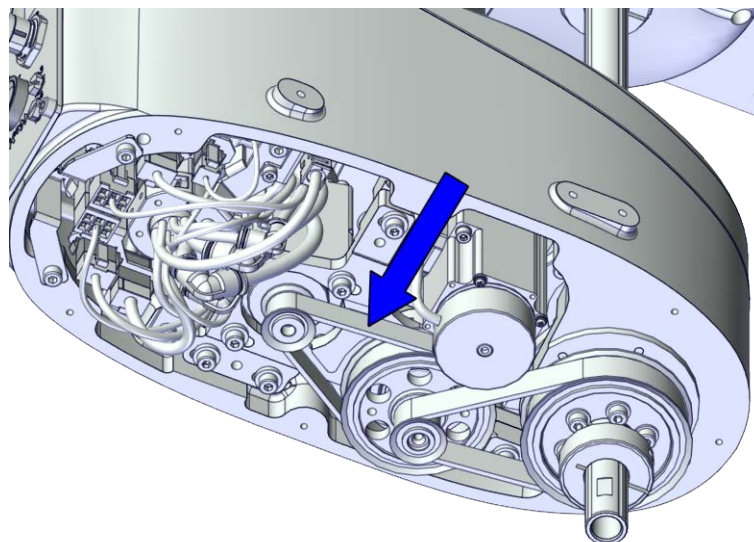

xx1800003401

Required spare parts



Note

The spare part numbers that are listed in the table can be out of date. See the latest spare parts of the IRB 910INV via myABB Business Portal, www.abb.com/myABB.

Spare part	Article number	Note
Timing belt	3HAC061863-001	

Required tools and equipment

Equipment	Article number	Note
Standard toolkit	-	Content is defined in section Standard toolkit on page 840 .
Calibration tool box, Axis Calibration	3HAC074119-001	Delivered as a set of calibration tools. Required if Axis Calibration is the valid calibration method for the robot. ⁱ
24 VDC power supply	-	Used to release the motor brakes.
Sonic tension meter	-	Used for measuring the timing belt tension.

ⁱ The robot is calibrated by either manual calibration or Axis Calibration at ABB factory before delivery. Always use the same calibration method as used at the factory. Information about valid calibration method is found on the calibration label or in the calibration menu on the FlexPendant.

Continues on next page

5 Repair

5.6.8 Replacing the axis-4 timing belt

Continued

If no data is found related to standard calibration, manual calibration is used as default.

Required consumables

Consumable	Article number	Note
Cable straps	-	

Deciding calibration routine

Decide which calibration routine to be used, based on the information in the table. Depending on which routine is chosen, action might be required prior to beginning the repair work of the robot, see the table.

	Action	Note
1	Decide which calibration routine to use for calibrating the robot. <ul style="list-style-type: none">Reference calibration. External cable packages (DressPack) and tools can stay fitted on the robot.Fine calibration. All external cable packages (DressPack) and tools must be removed from the robot.	
	If the robot is to be calibrated with reference calibration: Find previous reference values for the axis or create new reference values. These values are to be used after the repair procedure is completed, for calibration of the robot. If no previous reference values exist, and no new reference values can be created, then reference calibration is not possible.	Follow the instructions given in the reference calibration routine on the FlexPendant to create reference values. Creating new values requires possibility to move the robot. Read more about reference calibration for Axis Calibration in Reference calibration routine on page 798 .
	If the robot is to be calibrated with fine calibration: Remove all external cable packages (DressPack) and tools from the robot.	



Removing the axis-4 timing belt

Use these procedures to remove the axis-4 timing belt.

Preparations before removing the axis-4 timing belt

	Action	Note
1	Decide which calibration routine to use, and take actions accordingly prior to beginning the repair procedure.	
2	If there is no enough space for the maintenance work, remove the robot from the wall and place it on the maintenance bracket.  CAUTION Do not lay down the robot during the transportation, always keep it straight. If the robot lay down in any situation, the grease may come out from gearbox.	

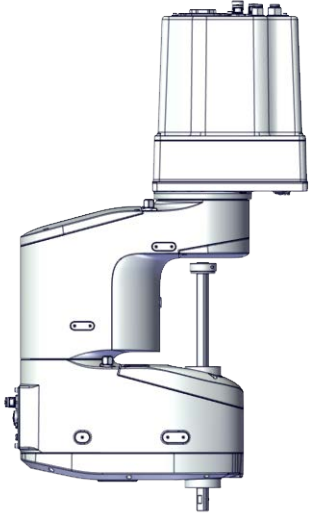
Continues on next page

	Action	Note
3	Jog all axes to zero position.	 <p>xx1800002825</p>
4	 <p>DANGER</p> <p>Turn off all:</p> <ul style="list-style-type: none"> • electric power supply • hydraulic pressure supply • air pressure supply <p>to the robot, before entering the safeguarded space.</p>	
5	 <p>CAUTION</p> <p>For robots with protection type Clean Room Always cut the paint with a knife and grind the paint edge when disassembling parts of the robot! See Cut the paint or surface on the robot before replacing parts on page 118.</p>	

Removing the lower cover

	Action	Note
1	 <p>DANGER</p> <p>Make sure that all supplies for electrical power, hydraulic pressure, and air pressure are turned off.</p>	

Continues on next page



5 Repair

5.6.8 Replacing the axis-4 timing belt

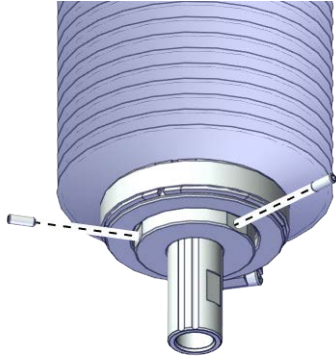
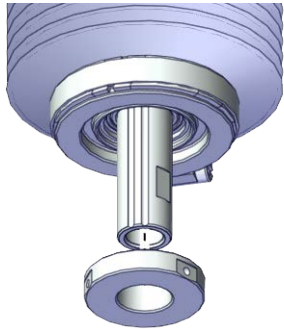
Continued





	Action	Note
2	 CAUTION For robots with protection type Clean Room Always cut the paint with a knife and grind the paint edge when disassembling parts of the robot! See Cut the paint or surface on the robot before replacing parts on page 118 .	
3	For robots with protection class IP54 (option 3350-540) For robots with protection type Clean Room (option 3351-1) Loose the locking screws.	 <small>xx1900001606</small>
4	For robots with protection class IP54 (option 3350-540) For robots with protection type Clean Room (option 3351-1) Remove the lower cover from the ball screw.	 <small>xx1900001607</small>

Removing the cover of the outer arm

	Action	Note
1	 DANGER Make sure that all supplies for electrical power, hydraulic pressure, and air pressure are turned off.	
2	 CAUTION For robots with protection type Clean Room Always cut the paint with a knife and grind the paint edge when disassembling parts of the robot! See Cut the paint or surface on the robot before replacing parts on page 118 .	

Continues on next page

5.6.8 Replacing the axis-4 timing belt
Continued

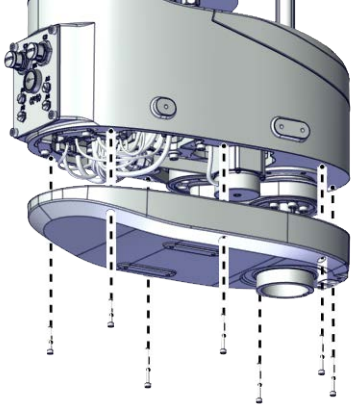
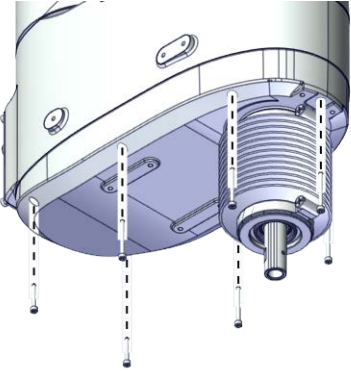
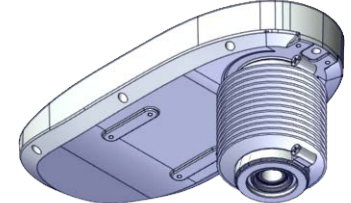
	Action	Note
3	<p>Remove the screws on the cover of the outer arm and remove the cover.</p> <p> Note</p> <p>For robots with protection class IP54 (option 3350-540)</p> <p>For robots with protection type Clean Room (option 3351-1)</p> <p>Remove the cover with bellow and housing.</p> <p> Note</p> <p>The bellow does not need to be removed separately.</p> <p> CAUTION</p> <p>There is a gasket in the cover. Be careful when removing the cover with bellow and housing.</p> <p> Tip</p> <p>Check the gasket and replace it if needed.</p>	<p>For robots with protection class IP30 (option 3350-300)</p>  <p>xx1800002836</p> <p>For robots with protection class IP54 (option 3350-540)</p> <p>For robots with protection type Clean Room (option 3351-1)</p>  <p>xx1900001631</p>  <p>xx1900001632</p>

Removing the bracket for the process hub

	Action	Note
1	<p> DANGER</p> <p>Make sure that all supplies for electrical power, hydraulic pressure, and air pressure are turned off.</p>	

Continues on next page



5 Repair

5.6.8 Replacing the axis-4 timing belt

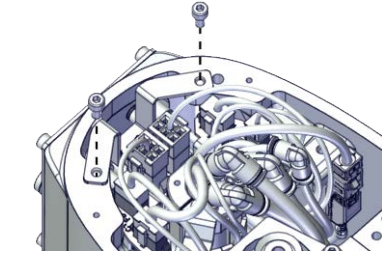
Continued

	Action	Note
2	 CAUTION For robots with protection type Clean Room Always cut the paint with a knife and grind the paint edge when disassembling parts of the robot! See Cut the paint or surface on the robot before replacing parts on page 118 .	
3	Remove the screws on the bracket and take it out carefully.	 xx1800002839

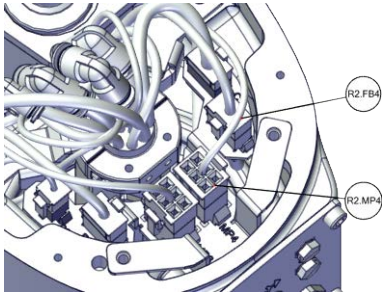

Disconnecting the connectors for axis-4 motor

	Action	Note
1	 DANGER Make sure that all supplies for electrical power, hydraulic pressure, and air pressure are turned off.	
2	 CAUTION For robots with protection type Clean Room Always cut the paint with a knife and grind the paint edge when disassembling parts of the robot! See Cut the paint or surface on the robot before replacing parts on page 118 .	
3	Disconnect the connectors. <ul style="list-style-type: none"> • R2.MP4 • R2.FB4 	 xx1900000065

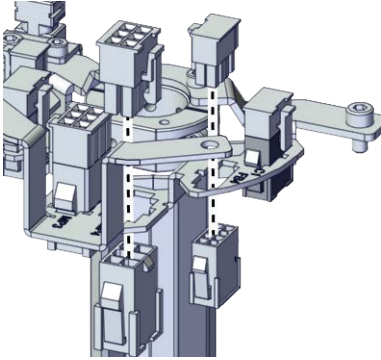
Continues on next page

	Action	Note
4	Snap loose and remove the female head of the connectors from the bracket.	 <p>xx190000066</p>

Removing the pulley pre-assembly with the motor

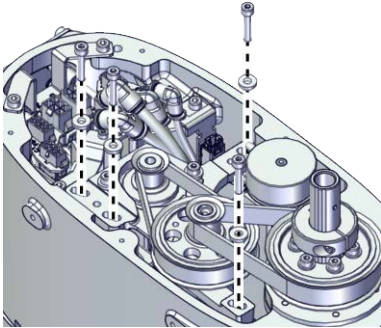
	Action	Note
1	 DANGER Make sure that all supplies for electrical power, hydraulic pressure, and air pressure are turned off.	
2	 CAUTION For robots with protection type Clean Room Always cut the paint with a knife and grind the paint edge when disassembling parts of the robot! See Cut the paint or surface on the robot before replacing parts on page 118.	
3	 DANGER Make sure that the ball screw is supported with something. The sudden drop of the ball screw due the lost of the axis-4 motor may cause danger.	
4	Remove the screws.	 <p>xx1800002888</p>

Continues on next page



5 Repair

5.6.8 Replacing the axis-4 timing belt

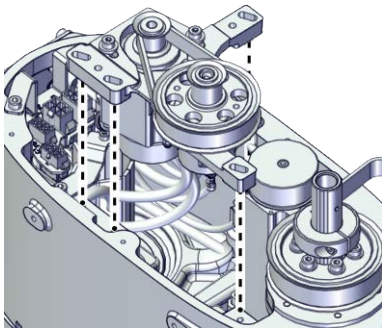
Continued

	Action	Note
5	Remove the pulley pre-assembly and the timing belt.	 <p>xx1800002889</p>

Removing the axis-4 timing belt

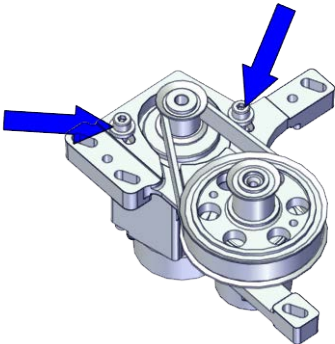
	Action	Note
1	 DANGER Make sure that all supplies for electrical power, hydraulic pressure, and air pressure are turned off.	
2	 CAUTION For robots with protection type Clean Room Always cut the paint with a knife and grind the paint edge when disassembling parts of the robot! See Cut the paint or surface on the robot before replacing parts on page 118 .	
3	Loosen the screws of the axis-4 motor sub-assembly to let the axis-4 timing belt be free.	 <p>xx1800002894</p>

Continues on next page

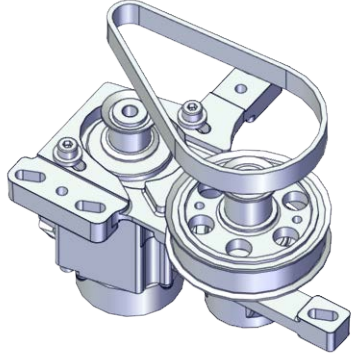
	Action	Note
4	Remove the timing belt.	 <p data-bbox="1059 701 1166 719">xx1800003403</p>

Refitting the axis-4 timing belt

Use these procedures to refit the axis-4 timing belt.

Refitting the axis-4 timing belt

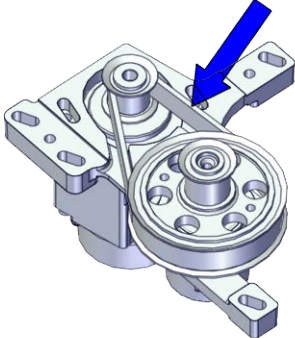
	Action	Note
1	<p>For robots with protection type Clean Room: Clean the joints that have been opened and wipe the parts free from particles with spirit on a lint free. See Cut the paint or surface on the robot before replacing parts on page 118</p> <p> Note</p> <p>After all repair work, wipe the Clean Room robot free from particles with spirit on a lint free cloth.</p>	
2	Refit the timing belt to the pulley.	 <p data-bbox="1059 1675 1166 1693">xx1800002892</p>

Continues on next page

5 Repair

5.6.8 Replacing the axis-4 timing belt

Continued

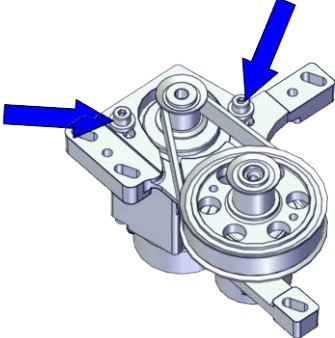
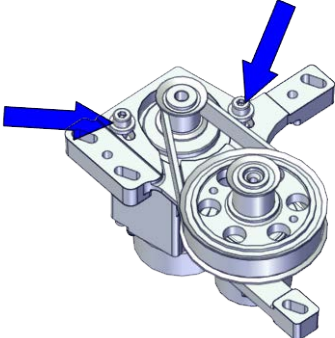
	Action	Note
3	Refit the timing belt to the motor. Ensure that the belt runs correctly in the grooves.	<p>Timing belt: 3HAC061863-001</p>  <p>xx1800002894</p>
4	Refit the screws and washers.	<p>Screws: Hex socket head cap screw M4x16 12.9 Lafre 2C2B/FC6.9 (2 pcs) Washers: Washer 4.3x10x2 steel (2 pcs) Tightening torque: 3 Nm ±10%</p>  <p>xx1800002894</p>
5	Use a sonic tension meter to measure the timing belt tension.	<p>Used belt: 178-217Hz New belt: 210-268Hz</p>
6	If the timing belt tension does not meet the requirement, loosen the motor screws and readjust.	

Refitting the pulley pre-assembly with the motor

	Action	Note
1	<p>For robots with protection type Clean Room: Clean the joints that have been opened and wipe the parts free from particles with spirit on a lint free. See Cut the paint or surface on the robot before replacing parts on page 118</p> <p> Note</p> <p>After all repair work, wipe the Clean Room robot free from particles with spirit on a lint free cloth.</p>	

Continues on next page

5.6.8 Replacing the axis-4 timing belt

Continued

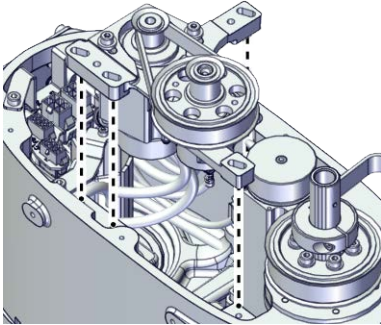
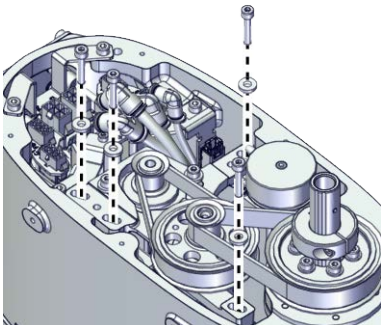
	Action	Note
2	Refit the pulley pre-assembly with the motor to the outer arm.	<p>Screws: Hex socket head cap screw M4x20 12.9 Lafre 2C2B/FC6.9 (4 pcs) Washers: Washer 4.3x10x2 steel (4 pcs) Tightening torque: 3 Nm ±10%</p>  <p>xx1800002889</p>
3	Secure with the screws.	 <p>xx1800002888</p>

Refitting the axis-4 second timing belt



	Action	Note
1	<p>For robots with protection type Clean Room: Clean the joints that have been opened and wipe the parts free from particles with spirit on a lint free. See Cut the paint or surface on the robot before replacing parts on page 118</p> <p> Note After all repair work, wipe the Clean Room robot free from particles with spirit on a lint free cloth.</p>	

Continues on next page

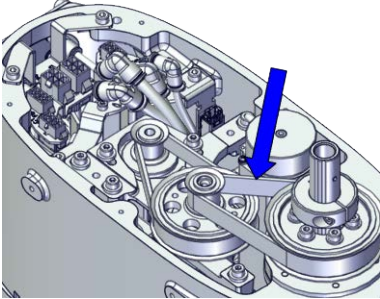

5 Repair

5.6.8 Replacing the axis-4 timing belt

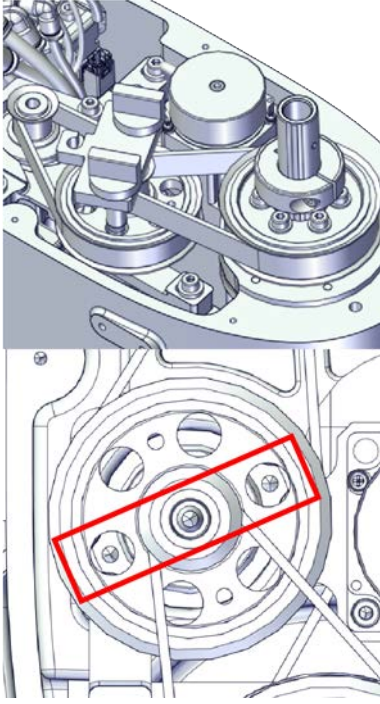
Continued

	Action	Note
2	Refit the timing belt to the pulley and the motor. Ensure that the belt runs correctly in the grooves.	 <p>xx1800002895</p> <p>Timing belt: 3HAC061864-001</p>
3	Install the axis-4 belt tension adjustment tool to the motor.  Note Just tighten the tool.	<p>Belt tension adjustment tool set, stage two of axis 4:-</p>  <p>xx1900000096</p>

Continues on next page

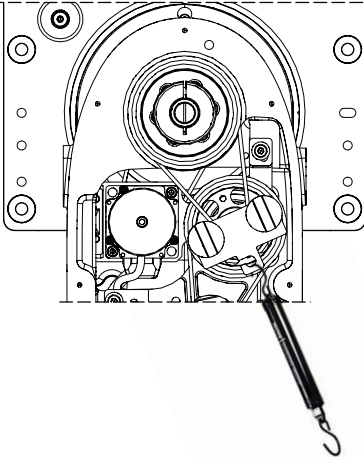
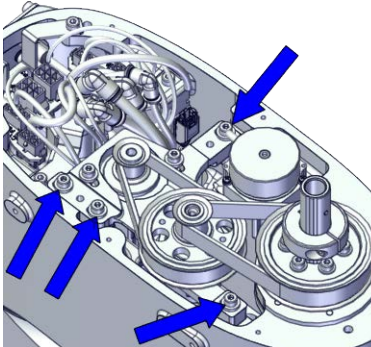
	Action	Note
4	<p>Use a handheld dynamometer hooking to the screw and pull the dynamometer to make the tension falling in the allowed force range.</p> <p> Note</p> <p>During the measurement, make sure that all interferences that may affect the force are removed. Pay attention to the force application direction.</p> <p> Tip</p> <p>If the ball screw will interfere with the handheld dynamometer, adjust the ball screw manually.</p>	<p>Used belt: 84-96N New belt:120-132N</p>  <p>xx1900000097</p>
5	<p>Fasten the screws to the recommended tightening torque.</p>	<p>Tightening torque: 3 Nm ±10%</p>  <p>xx1800003389</p>
6	<p>Use a sonic tension meter to measure the timing belt tension.</p>	<p>Used belt: 257-314Hz New belt:304-389Hz</p>
7	<p>If the timing belt tension does not meet the requirement, loosen the motor screws and readjust.</p>	
8	<p>Remove the axis-4 belt tension adjustment tool.</p>	

Reconnecting the connectors for axis-4 motor





	Action	Note
1	<p>For robots with protection type Clean Room: Clean the joints that have been opened and wipe the parts free from particles with spirit on a lint free. See Cut the paint or surface on the robot before replacing parts on page 118</p> <p> Note</p> <p>After all repair work, wipe the Clean Room robot free from particles with spirit on a lint free cloth.</p>	

Continues on next page

5 Repair

5.6.8 Replacing the axis-4 timing belt

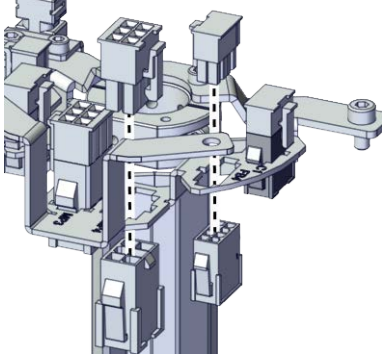
Continued

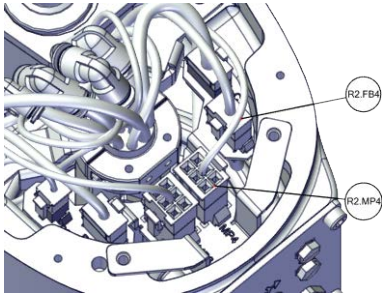
	Action	Note
2	<p>Route the cabling on the axis-4 motor behind the protected bracket to the bracket.</p> <p> CAUTION</p> <p>Correct cable routing is highly important. If the cables are routed and secured incorrectly the cables can be damaged.</p>	
	<p>Insert the female head of the connectors to the bracket accordingly.</p> <p> Tip</p> <p>The mistake proofing measure has been applied to the connectors, the connectors may be damaged if excessive force is used.</p>	 <p>xx1900000066</p>
3	<p>Reconnect the connectors.</p> <ul style="list-style-type: none"> • R2.MP4 • R2.FB4 <p> Tip</p> <p>See the number markings on the connectors for help to find the corresponding connector.</p>	 <p>xx1900000065</p>

Refitting the bracket for the process hub

	Action	Note
1	<p>For robots with protection type Clean Room: Clean the joints that have been opened and wipe the parts free from particles with spirit on a lint free. See Cut the paint or surface on the robot before replacing parts on page 118</p> <p> Note</p> <p>After all repair work, wipe the Clean Room robot free from particles with spirit on a lint free cloth.</p>	

Continues on next page

5.6.8 Replacing the axis-4 timing belt
Continued

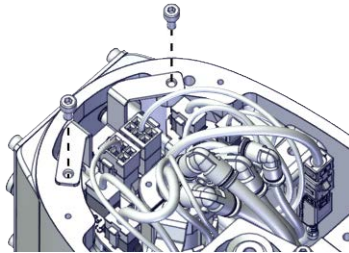
	Action	Note
2	Secure the bracket with screws.	<p>Screws: Hex socket head cap screw M4x8 12.9 Lafre 2C2B/FC6.9 (2 pcs)</p> <p>Tightening torque: 4 Nm \pm10%</p>  <p>xx1800002839</p>

Refitting the cover of the outer arm



	Action	Note
1	<p>For robots with protection type Clean Room: Clean the joints that have been opened and wipe the parts free from particles with spirit on a lint free. See Cut the paint or surface on the robot before replacing parts on page 118</p> <p> Note</p> <p>After all repair work, wipe the Clean Room robot free from particles with spirit on a lint free cloth.</p>	

Continues on next page

5 Repair

5.6.8 Replacing the axis-4 timing belt

Continued

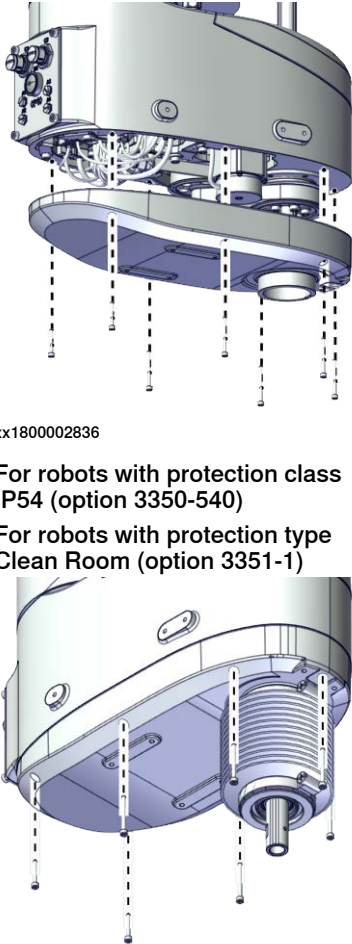
	Action	Note
2	<p>Refit the cover.</p> <p> Note</p> <p>For robots with protection class IP54 (option 3350-540)</p> <p>For robots with protection type Clean Room (option 3351-1)</p> <p>Refit the cover with bellow and housing.</p> <p>Check the gasket on the outer arm cover.</p> <p> Tip</p> <p>Replace the gasket if needed.</p>	<p>For IRB 910INV-3/0.35:</p> <p>Screw: Hex socket head cap screw M3x20 12.9 Lafre 2C2B/FC6.9 (2 pcs)</p> <p>Hex socket head cap screw M3x30 12.9 Lafre 2C2B/FC6.9 (5 pcs)</p> <p>Tightening torque: 1.2 Nm ±10%</p> <p>For IRB 910INV-6/0.55:</p> <p>Screw: Hex socket head cap screw M3x20 12.9 Lafre 2C2B/FC6.9 (2 pcs)</p> <p>Hex socket head cap screw M3x30 12.9 Lafre 2C2B/FC6.9 (7 pcs)</p> <p>Tightening torque: 1.2 Nm ±10%</p>
3	<p>Refit the screws.</p>	<p>For robots with protection class IP30 (option 3350-300)</p>  <p>xx1800002836</p> <p>For robots with protection class IP54 (option 3350-540)</p> <p>For robots with protection type Clean Room (option 3351-1)</p> <p>xx1900001631</p>

Continues on next page

Refitting the lower cover

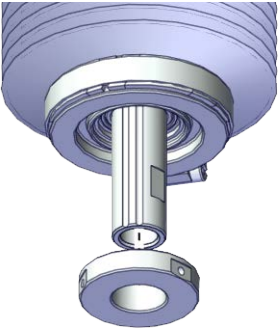
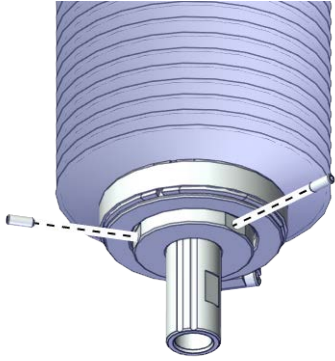
	Action	Note
1	<p>For robots with protection type Clean Room: Clean the joints that have been opened and wipe the parts free from particles with spirit on a lint free. See Cut the paint or surface on the robot before replacing parts on page 118</p> <p> Note</p> <p>After all repair work, wipe the Clean Room robot free from particles with spirit on a lint free cloth.</p>	
2	<p>For robots with protection class IP54 (option 3350-540)</p> <p>For robots with protection type Clean Room (option 3351-1)</p> <p>Refit the lower cover to the ball screw.</p>	 <p>xx1900001607</p>
3	<p>For robots with protection class IP54 (option 3350-540)</p> <p>For robots with protection type Clean Room (option 3351-1)</p> <p>Refit the locking screws.</p>	<p>Screws: Hexagon socket set screws with flat point, ISO 4026 stainless steel M3x8 (2 pcs)</p> <p>Tightening torque: 0.6 Nm ±10%</p>  <p>xx1900001606</p>



Continues on next page

5 Repair

5.6.8 Replacing the axis-4 timing belt

Continued

Concluding procedure

	Action	Note
1	<p>For robots with protection type Clean Room: Seal and paint the joints that have been opened. See Cut the paint or surface on the robot before replacing parts on page 118</p> <p> Note</p> <p>After all repair work, wipe the Clean Room robot free from particles with spirit on a lint free cloth.</p>	
2	Recalibrate the robot.	Calibration is detailed in section Calibration on page 771 .
3	<p> DANGER</p> <p>Make sure all safety requirements are met when performing the first test run. See Test run after installation, maintenance, or repair on page 56.</p>	

5.6.9 Replacing the pulley pre-assembly

Location of the pulley pre-assembly

The pulley pre-assembly is located as shown in the figure.

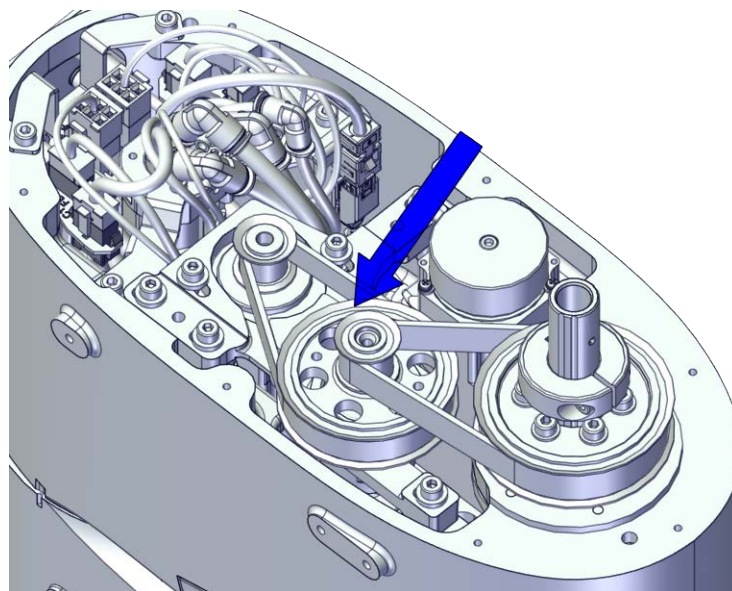

xx1800003404

Required spare parts



Note

The spare part numbers that are listed in the table can be out of date. See the latest spare parts of the IRB 910INV via myABB Business Portal, www.abb.com/myABB.

Spare part	Article number	Note
Pulley pre-assembly	3HAC073057-001	

Required tools and equipment

Equipment	Article number	Note
Standard toolkit	-	Content is defined in section Standard toolkit on page 840 .
Calibration tool box, Axis Calibration	3HAC074119-001	Delivered as a set of calibration tools. Required if Axis Calibration is the valid calibration method for the robot. ⁱ
24 VDC power supply	-	Used to release the motor brakes.

Continues on next page

5 Repair

5.6.9 Replacing the pulley pre-assembly

Continued

Equipment	Article number	Note
Belt tension adjustment tool set, stage two of axis 4	-	Included in the special toolkit 3HAC073070-001. Used to adjust the tension of axis-4 timing belt. Special tool for L2
Sonic tension meter	-	Used for measuring the timing belt tension.
Handheld dynamometer	-	Used for measuring the timing belt tension.

- i The robot is calibrated by either manual calibration or Axis Calibration at ABB factory before delivery. Always use the same calibration method as used at the factory.
Information about valid calibration method is found on the calibration label or in the calibration menu on the FlexPendant.
If no data is found related to standard calibration, manual calibration is used as default.

Required consumables

Consumable	Article number	Note
Cable straps	-	

Deciding calibration routine

Decide which calibration routine to be used, based on the information in the table. Depending on which routine is chosen, action might be required prior to beginning the repair work of the robot, see the table.



	Action	Note
1	Decide which calibration routine to use for calibrating the robot. <ul style="list-style-type: none">Reference calibration. External cable packages (DressPack) and tools can stay fitted on the robot.Fine calibration. All external cable packages (DressPack) and tools must be removed from the robot.	
	If the robot is to be calibrated with reference calibration: Find previous reference values for the axis or create new reference values. These values are to be used after the repair procedure is completed, for calibration of the robot. If no previous reference values exist, and no new reference values can be created, then reference calibration is not possible.	Follow the instructions given in the reference calibration routine on the FlexPendant to create reference values. Creating new values requires possibility to move the robot. Read more about reference calibration for Axis Calibration in Reference calibration routine on page 798 .
	If the robot is to be calibrated with fine calibration: Remove all external cable packages (DressPack) and tools from the robot.	

Continues on next page

Removing the pulley pre-assembly

Use these procedures to remove the pulley pre-assembly.

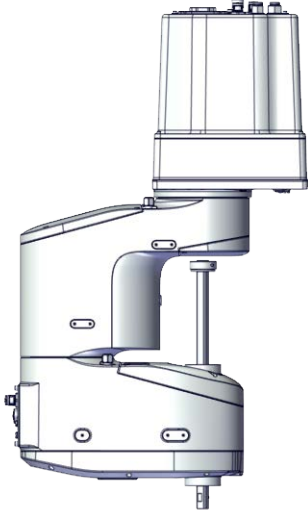
Preparations before removing the pulley pre-assembly

	Action	Note
1	Decide which calibration routine to use, and take actions accordingly prior to beginning the repair procedure.	
2	<p>If there is no enough space for the maintenance work, remove the robot from the wall and place it on the maintenance bracket.</p> <p> CAUTION</p> <p>Do not lay down the robot during the transportation, always keep it straight. If the robot lay down in any situation, the grease may come out from gearbox.</p>	
3	Jog all axes to zero position.	 <p>xx1800002825</p>
4	<p> DANGER</p> <p>Turn off all:</p> <ul style="list-style-type: none"> • electric power supply • hydraulic pressure supply • air pressure supply <p>to the robot, before entering the safeguarded space.</p>	
5	<p> CAUTION</p> <p>For robots with protection type Clean Room Always cut the paint with a knife and grind the paint edge when disassembling parts of the robot! See <i>Cut the paint or surface on the robot before replacing parts on page 118.</i></p>	



Continues on next page

5 Repair

5.6.9 Replacing the pulley pre-assembly

Continued



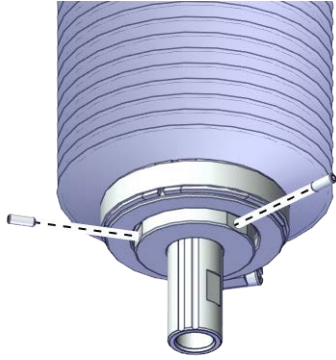
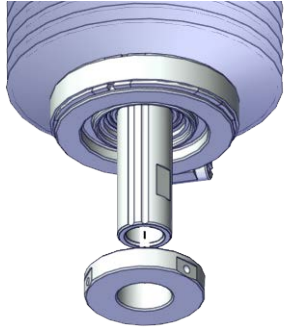

Removing the lower cover

	Action	Note
1	 DANGER Make sure that all supplies for electrical power, hydraulic pressure, and air pressure are turned off.	
2	 CAUTION For robots with protection type Clean Room Always cut the paint with a knife and grind the paint edge when disassembling parts of the robot! See Cut the paint or surface on the robot before replacing parts on page 118 .	
3	For robots with protection class IP54 (option 3350-540) For robots with protection type Clean Room (option 3351-1) Loose the locking screws.	 <small>xx1900001606</small>
4	For robots with protection class IP54 (option 3350-540) For robots with protection type Clean Room (option 3351-1) Remove the lower cover from the ball screw.	 <small>xx1900001607</small>

Removing the cover of the outer arm

	Action	Note
1	 DANGER Make sure that all supplies for electrical power, hydraulic pressure, and air pressure are turned off.	

Continues on next page

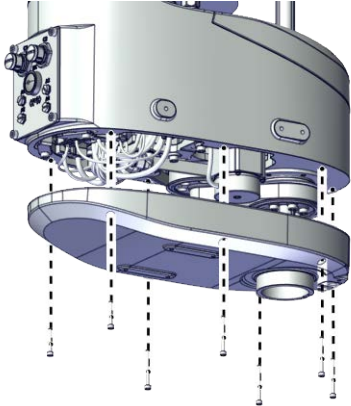
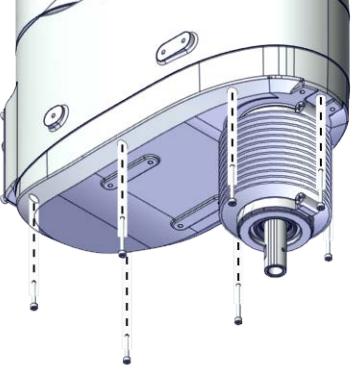
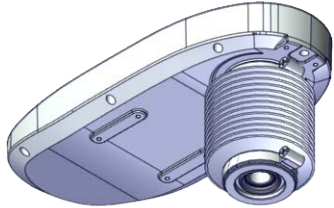
	Action	Note
2	<p> CAUTION</p> <p>For robots with protection type Clean Room Always cut the paint with a knife and grind the paint edge when disassembling parts of the robot! See <i>Cut the paint or surface on the robot before replacing parts on page 118.</i></p>	
3	<p>Remove the screws on the cover of the outer arm and remove the cover.</p> <p> Note</p> <p>For robots with protection class IP54 (option 3350-540) For robots with protection type Clean Room (option 3351-1) Remove the cover with bellow and housing.</p> <p> Note</p> <p>The bellow does not need to be removed separately.</p> <p> CAUTION</p> <p>There is a gasket in the cover. Be careful when removing the cover with bellow and housing.</p> <p> Tip</p> <p>Check the gasket and replace it if needed.</p>	<p>For robots with protection class IP30 (option 3350-300)</p>  <p>xx1800002836</p> <p>For robots with protection class IP54 (option 3350-540) For robots with protection type Clean Room (option 3351-1)</p>  <p>xx1900001631</p>  <p>xx1900001632</p>



Continues on next page

5 Repair



5.6.9 Replacing the pulley pre-assembly

Continued

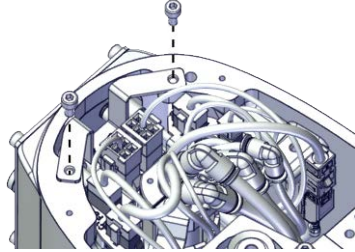
Removing the bracket for the process hub

	Action	Note
1	 DANGER Make sure that all supplies for electrical power, hydraulic pressure, and air pressure are turned off.	
2	 CAUTION For robots with protection type Clean Room Always cut the paint with a knife and grind the paint edge when disassembling parts of the robot! See Cut the paint or surface on the robot before replacing parts on page 118 .	
3	Remove the screws on the bracket and take it out carefully.	 xx1800002839

Disconnecting the connectors for axis-4 motor



	Action	Note
1	 DANGER Make sure that all supplies for electrical power, hydraulic pressure, and air pressure are turned off.	
2	 CAUTION For robots with protection type Clean Room Always cut the paint with a knife and grind the paint edge when disassembling parts of the robot! See Cut the paint or surface on the robot before replacing parts on page 118 .	

Continues on next page

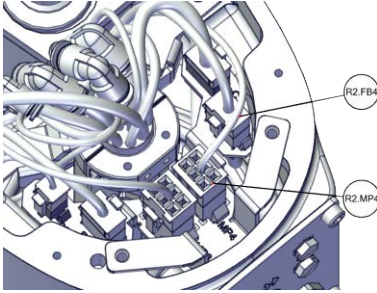
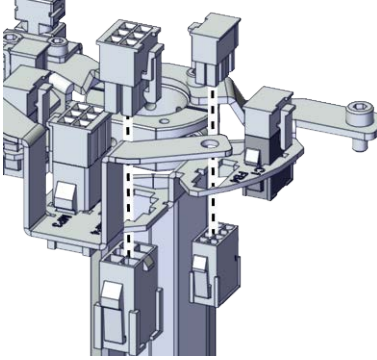
5.6.9 Replacing the pulley pre-assembly
Continued

	Action	Note
3	Disconnect the connectors. <ul style="list-style-type: none"> • R2.MP4 • R2.FB4 	 <p>xx1900000065</p>
4	Snap loose and remove the female head of the connectors from the bracket.	 <p>xx1900000066</p>

Removing the pulley pre-assembly with the motor

	Action	Note
1	 <p>DANGER</p> <p>Make sure that all supplies for electrical power, hydraulic pressure, and air pressure are turned off.</p>	
2	 <p>CAUTION</p> <p>For robots with protection type Clean Room Always cut the paint with a knife and grind the paint edge when disassembling parts of the robot! See Cut the paint or surface on the robot before replacing parts on page 118.</p>	
3	 <p>DANGER</p> <p>Make sure that the ball screw is supported with something. The sudden drop of the ball screw due the lost of the axis-4 motor may cause danger.</p>	

Continues on next page



5 Repair

5.6.9 Replacing the pulley pre-assembly

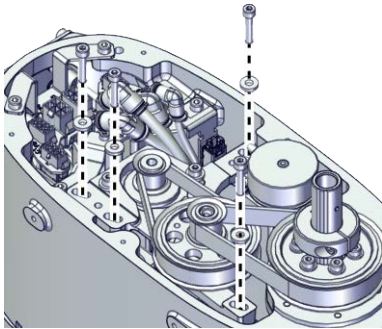
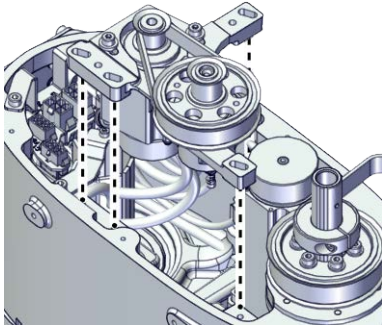
Continued



	Action	Note
4	Remove the screws.	 <p>xx1800002888</p>
5	Remove the pulley pre-assembly and the timing belt.	 <p>xx1800002889</p>

Separating the axis-4 motor sub-assembly with the pulley pre-assembly

	Action	Note
1	 DANGER Make sure that all supplies for electrical power, hydraulic pressure, and air pressure are turned off.	
2	 CAUTION For robots with protection type Clean Room Always cut the paint with a knife and grind the paint edge when disassembling parts of the robot! See Cut the paint or surface on the robot before replacing parts on page 118.	

Continues on next page

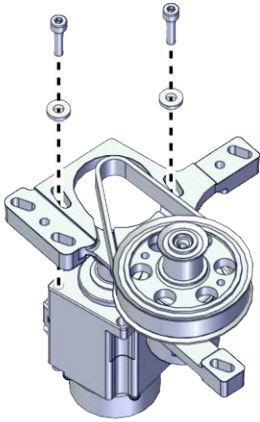

5.6.9 Replacing the pulley pre-assembly
Continued

	Action	Note
3	Remove the screws and washers.	 <p data-bbox="1061 772 1173 795">xx1800002890</p>
4	Remove the motor and timing belt.  Tip Move the internal harness out of the way.	

Refitting the pulley pre-assembly

Use these procedures to refit the pulley pre-assembly.

Refitting the axis-4 motor sub-assembly to the pulley pre-assembly

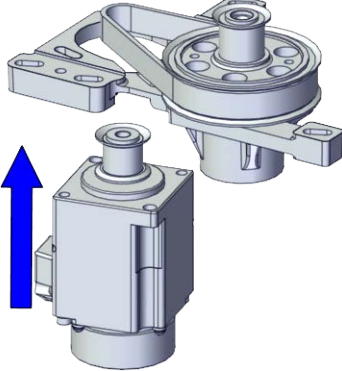
	Action	Note
1	For robots with protection type Clean Room: Clean the joints that have been opened and wipe the parts free from particles with spirit on a lint free. See Cut the paint or surface on the robot before replacing parts on page 118  Note After all repair work, wipe the Clean Room robot free from particles with spirit on a lint free cloth.	
2	Refit the motor to the pulley pre-assembly.  Tip Move the internal harness out of the way.	 <p data-bbox="1061 1780 1173 1803">xx1800002891</p>

Continues on next page

5 Repair

5.6.9 Replacing the pulley pre-assembly

Continued

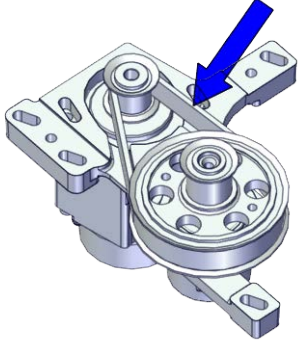
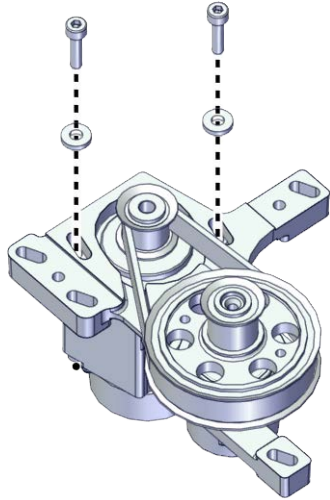
	Action	Note
3	Refit the timing belt to the motor. Ensure that the belt runs correctly in the grooves.	<p>Timing belt: 3HAC061863-001</p>  <p>xx1800002892</p>
4	Refit the screws and washers.	<p>Screws: Hex socket head cap screw M4x16 12.9 Lafre 2C2B/FC6.9 (2 pcs) Washers: Washer 4.3x10x2 steel (2 pcs) Tightening torque: 3 Nm \pm10%</p>  <p>xx1800002893</p>
5	Use a sonic tension meter to measure the timing belt tension.	<p>Used belt: 178-217Hz New belt: 210-268Hz</p>

Continues on next page

5.6.9 Replacing the pulley pre-assembly
Continued

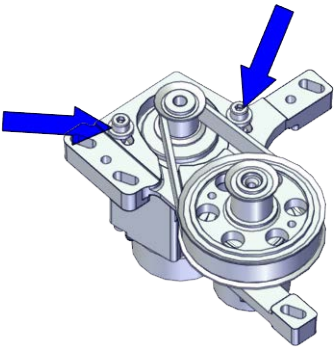
	Action	Note
6	If the timing belt tension does not meet the requirement, loosen the motor screws and readjust.	 <p>xx1800002894</p>

Refitting the pulley pre-assembly with the motor

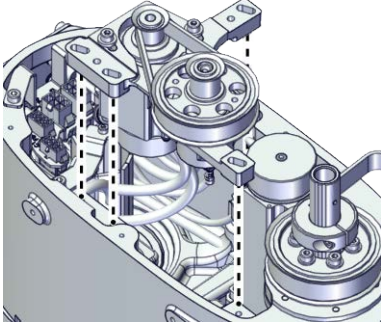
	Action	Note
1	<p>For robots with protection type Clean Room: Clean the joints that have been opened and wipe the parts free from particles with spirit on a lint free. See Cut the paint or surface on the robot before replacing parts on page 118</p> <p> Note</p> <p>After all repair work, wipe the Clean Room robot free from particles with spirit on a lint free cloth.</p>	
2	Refit the pulley pre-assembly with the motor to the outer arm.	<p>Screws: Hex socket head cap screw M4x20 12.9 Lafre 2C2B/FC6.9 (4 pcs) Washers: Washer 4.3x10x2 steel (4 pcs) Tightening torque: 3 Nm ±10%</p>  <p>xx1800002889</p>

Continues on next page

5 Repair

5.6.9 Replacing the pulley pre-assembly

Continued

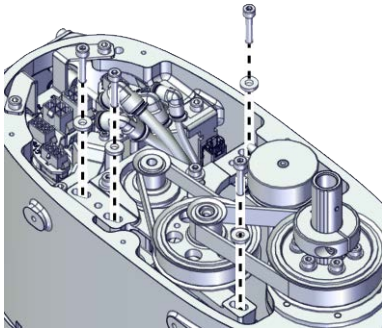

	Action	Note
3	Secure with the screws.	 <p>xx1800002888</p>

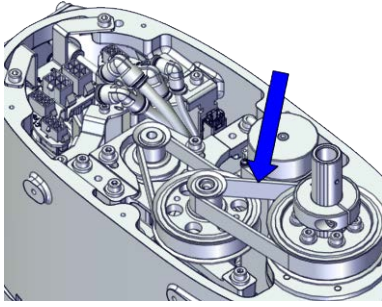
Refitting the axis-4 second timing belt

	Action	Note
1	<p>For robots with protection type Clean Room: Clean the joints that have been opened and wipe the parts free from particles with spirit on a lint free. See Cut the paint or surface on the robot before replacing parts on page 118</p> <p> Note</p> <p>After all repair work, wipe the Clean Room robot free from particles with spirit on a lint free cloth.</p>	
2	Refit the timing belt to the pulley and the motor. Ensure that the belt runs correctly in the grooves.	 <p>xx1800002895</p> <p>Timing belt: 3HAC061864-001</p>

Continues on next page

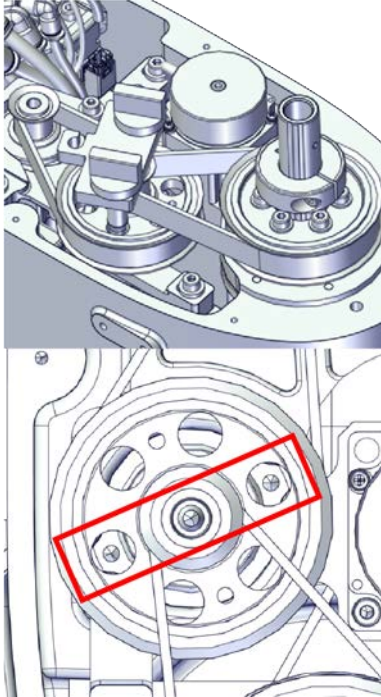
5.6.9 Replacing the pulley pre-assembly
Continued

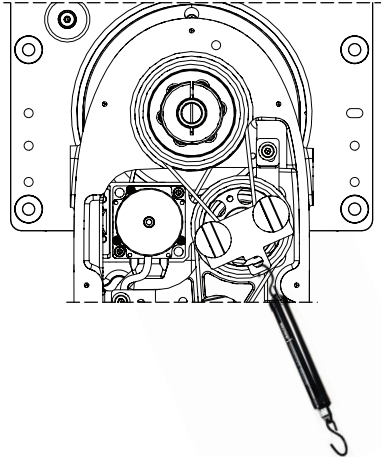
	Action	Note
3	<p>Install the axis-4 belt tension adjustment tool to the motor.</p> <p> Note</p> <p>Just tighten the tool.</p>	<p>Belt tension adjustment tool set, stage two of axis 4:-</p>  <p>xx1900000096</p>
4	<p>Use a handheld dynamometer hooking to the screw and pull the dynamometer to make the tension falling in the allowed force range.</p> <p> Note</p> <p>During the measurement, make sure that all interferences that may affect the force are removed. Pay attention to the force application direction.</p> <p> Tip</p> <p>If the ball screw will interfere with the handheld dynamometer, adjust the ball screw manually.</p>	<p>Used belt: 84-96N New belt:120-132N</p>  <p>xx1900000097</p>

Continues on next page



5 Repair

5.6.9 Replacing the pulley pre-assembly

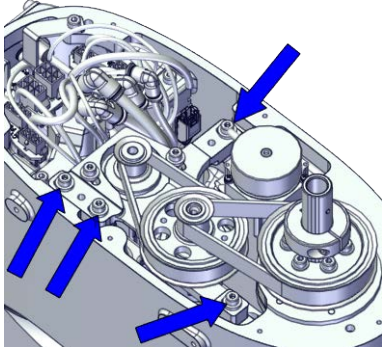
Continued



	Action	Note
5	Fasten the screws to the recommended tightening torque.	<p>Tightening torque: 3 Nm \pm10%</p>  <p>xx1800003389</p>
6	Use a sonic tension meter to measure the timing belt tension.	<p>Used belt: 257-314Hz New belt:304-389Hz</p>
7	If the timing belt tension does not meet the requirement, loosen the motor screws and readjust.	
8	Remove the axis-4 belt tension adjustment tool.	

Reconnecting the connectors for axis-4 motor

	Action	Note
1	<p>For robots with protection type Clean Room: Clean the joints that have been opened and wipe the parts free from particles with spirit on a lint free. See Cut the paint or surface on the robot before replacing parts on page 118</p> <p> Note</p> <p>After all repair work, wipe the Clean Room robot free from particles with spirit on a lint free cloth.</p>	
2	<p>Route the cabling on the axis-4 motor behind the protected bracket to the bracket.</p> <p> CAUTION</p> <p>Correct cable routing is highly important. If the cables are routed and secured incorrectly the cables can be damaged.</p>	

Continues on next page

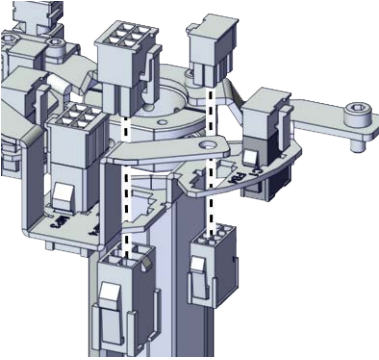
5.6.9 Replacing the pulley pre-assembly
Continued

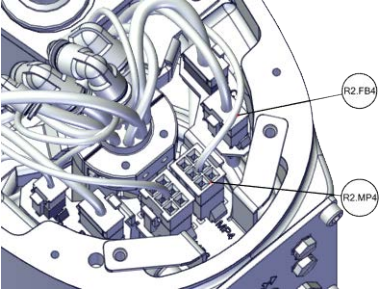
	Action	Note
	<p>Insert the female head of the connectors to the bracket accordingly.</p> <p> Tip</p> <p>The mistake proofing measure has been applied to the connectors, the connectors may be damaged if excessive force is used.</p>	 <p>xx1900000066</p>
3	<p>Reconnect the connectors.</p> <ul style="list-style-type: none"> • R2.MP4 • R2.FB4 <p> Tip</p> <p>See the number markings on the connectors for help to find the corresponding connector.</p>	 <p>xx1900000065</p>

Refitting the bracket for the process hub

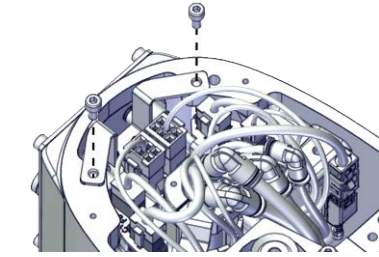
	Action	Note
1	<p>For robots with protection type Clean Room: Clean the joints that have been opened and wipe the parts free from particles with spirit on a lint free. See Cut the paint or surface on the robot before replacing parts on page 118</p> <p> Note</p> <p>After all repair work, wipe the Clean Room robot free from particles with spirit on a lint free cloth.</p>	
2	<p>Secure the bracket with screws.</p>	<p>Screws: Hex socket head cap screw M4x8 12.9 Lafre 2C2B/FC6.9 (2 pcs) Tightening torque: 4 Nm ±10%</p>  <p>xx1800002839</p>

Continues on next page

5 Repair

5.6.9 Replacing the pulley pre-assembly



Continued

Refitting the cover of the outer arm

	Action	Note
1	<p>For robots with protection type Clean Room: Clean the joints that have been opened and wipe the parts free from particles with spirit on a lint free. See Cut the paint or surface on the robot before replacing parts on page 118</p> <p> Note</p> <p>After all repair work, wipe the Clean Room robot free from particles with spirit on a lint free cloth.</p>	

Continues on next page

5.6.9 Replacing the pulley pre-assembly
Continued

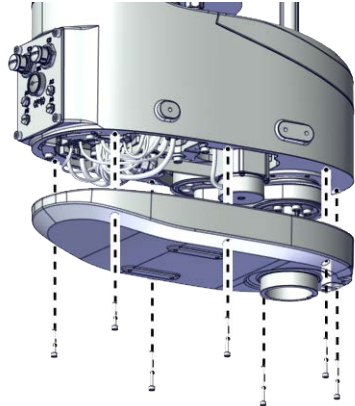
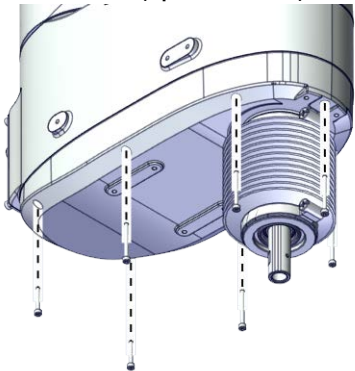
	Action	Note
2	<p>Refit the cover.</p> <p> Note</p> <p>For robots with protection class IP54 (option 3350-540)</p> <p>For robots with protection type Clean Room (option 3351-1)</p> <p>Refit the cover with bellow and housing.</p> <p>Check the gasket on the outer arm cover.</p> <p> Tip</p> <p>Replace the gasket if needed.</p>	<p>For IRB 910INV-3/0.35:</p> <p>Screw: Hex socket head cap screw M3x20 12.9 Lafre 2C2B/FC6.9 (2 pcs)</p> <p>Hex socket head cap screw M3x30 12.9 Lafre 2C2B/FC6.9 (5 pcs)</p> <p>Tightening torque: 1.2 Nm ±10%</p> <p>For IRB 910INV-6/0.55:</p> <p>Screw: Hex socket head cap screw M3x20 12.9 Lafre 2C2B/FC6.9 (2 pcs)</p> <p>Hex socket head cap screw M3x30 12.9 Lafre 2C2B/FC6.9 (7 pcs)</p> <p>Tightening torque: 1.2 Nm ±10%</p> <p>For robots with protection class IP30 (option 3350-300)</p>
3	<p>Refit the screws.</p>	 <p>xx1800002836</p> <p>For robots with protection class IP54 (option 3350-540)</p> <p>For robots with protection type Clean Room (option 3351-1)</p>  <p>xx1900001631</p>

Continues on next page

5 Repair

5.6.9 Replacing the pulley pre-assembly

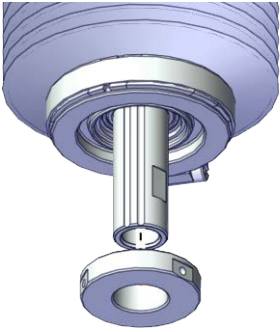
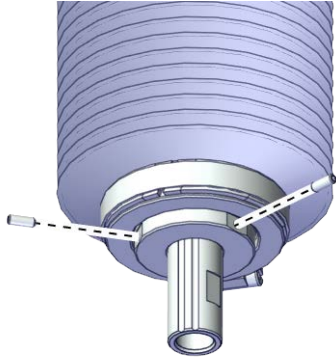

Continued

Refitting the lower cover

	Action	Note
1	<p>For robots with protection type Clean Room: Clean the joints that have been opened and wipe the parts free from particles with spirit on a lint free. See Cut the paint or surface on the robot before replacing parts on page 118</p> <p> Note</p> <p>After all repair work, wipe the Clean Room robot free from particles with spirit on a lint free cloth.</p>	
2	<p>For robots with protection class IP54 (option 3350-540) For robots with protection type Clean Room (option 3351-1) Refit the lower cover to the ball screw.</p>	 <p>xx1900001607</p>
3	<p>For robots with protection class IP54 (option 3350-540) For robots with protection type Clean Room (option 3351-1) Refit the locking screws.</p>	<p>Screws: Hexagon socket set screws with flat point, ISO 4026 stainless steel M3x8 (2 pcs) Tightening torque: 0.6 Nm \pm10%</p>  <p>xx1900001606</p>

Continues on next page

Concluding procedure

	Action	Note
1	<p>For robots with protection type Clean Room: Seal and paint the joints that have been opened. See Cut the paint or surface on the robot before replacing parts on page 118</p> <p> Note</p> <p>After all repair work, wipe the Clean Room robot free from particles with spirit on a lint free cloth.</p>	
2	Recalibrate the robot.	Calibration is detailed in section Calibration on page 771 .
3	<p> DANGER</p> <p>Make sure all safety requirements are met when performing the first test run. See Test run after installation, maintenance, or repair on page 56.</p>	

5 Repair

5.6.10 Replacing the outer arm

5.6.10 Replacing the outer arm

Location of the outer arm

The outer arm is located as shown in the figure.

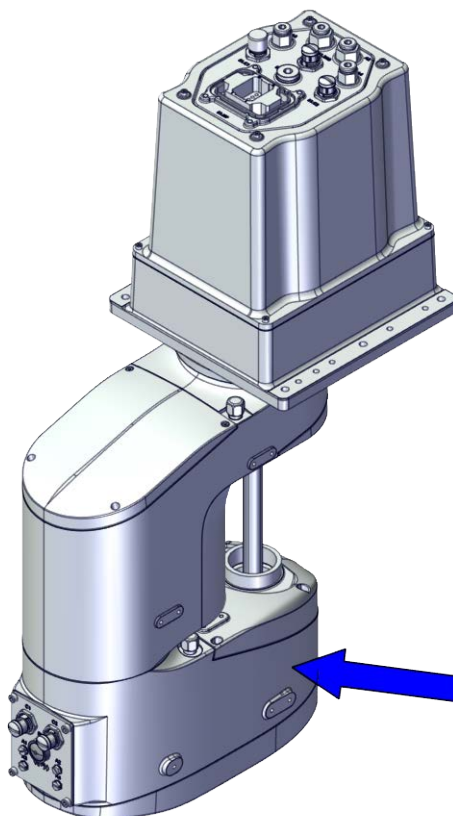

xx1800003405

Required spare parts



Note

The spare part numbers that are listed in the table can be out of date. See the latest spare parts of the IRB 910INV via myABB Business Portal, www.abb.com/myABB.

Spare part	Article number	Note
Outer arm, 350 mm	3HAC073053-001	
Outer arm, 550 mm	3HAC073064-001	
Outer arm cover casting, 350 mm	3HAC073059-001	
Outer arm cover casting, 550 mm	3HAC073067-001	
Outer arm cover, 350 mm	3HAC073058-001	
Outer arm cover, 550 mm	3HAC073066-001	
Outer arm, 350 mm, Clean Room	3HAC073229-001	Used with protection type Clean Room.

Continues on next page

Spare part	Article number	Note
Outer arm, 550 mm, Clean Room	3HAC073233-001	Used with protection type Clean Room.
Outer arm cover casting, 350 mm, Clean Room	3HAC073231-001	Used with protection type Clean Room.
Outer arm cover casting, 550 mm, Clean Room	3HAC073235-001	Used with protection type Clean Room.
Outer arm cover, 350 mm, Clean Room	3HAC073230-001	Used with protection type Clean Room.
Outer arm cove, 550 mm, Clean Room	3HAC073234-001	Used with protection type Clean Room.
Gasket, casting cover, 350 mm	3HAC061870-001	Replace if damaged.
Gasket, casting cover, 550 mm	3HAC061871-001	Replace if damaged.
Gasket, cover, 350 mm	3HAC066920-001	Replace if damaged.
Gasket, cover, 550 mm	3HAC066921-001	Replace if damaged.
Gasket, Process Hub	3HAC061872-001	Replace if damaged.

Required tools and equipment

Equipment	Article number	Note
Standard toolkit	-	Content is defined in section Standard toolkit on page 840 .
Calibration tool box, Axis Calibration	3HAC074119-001	Delivered as a set of calibration tools. Required if Axis Calibration is the valid calibration method for the robot. ⁱ
24 VDC power supply	-	Used to release the motor brakes.
Belt tension adjustment tool set, axis 1&2	-	Included in the special toolkit 3HAC073070-001. Used to adjust the tension of axis-1&2 timing belts. Special tool for L2
Belt tension adjustment tool set, stage two of axis 4	-	Included in the special toolkit 3HAC073070-001. Used to adjust the tension of axis-4 timing belt. Special tool for L2
Sonic tension meter	-	Used for measuring the timing belt tension.
Handheld dynamometer	-	Used for measuring the timing belt tension.

ⁱ The robot is calibrated by either manual calibration or Axis Calibration at ABB factory before delivery. Always use the same calibration method as used at the factory. Information about valid calibration method is found on the calibration label or in the calibration menu on the FlexPendant.
If no data is found related to standard calibration, manual calibration is used as default.

Continues on next page

5 Repair

5.6.10 Replacing the outer arm

Continued

Required consumables

Consumable	Article number	Note
Cable straps	-	
Grease	3HAC029132-001	FM 222 Used to lubricate the cable harness.

Deciding calibration routine

Decide which calibration routine to be used, based on the information in the table. Depending on which routine is chosen, action might be required prior to beginning the repair work of the robot, see the table.

	Action	Note
1	Decide which calibration routine to use for calibrating the robot. <ul style="list-style-type: none">Reference calibration. External cable packages (DressPack) and tools can stay fitted on the robot.Fine calibration. All external cable packages (DressPack) and tools must be removed from the robot.	
	If the robot is to be calibrated with reference calibration: Find previous reference values for the axis or create new reference values. These values are to be used after the repair procedure is completed, for calibration of the robot. If no previous reference values exist, and no new reference values can be created, then reference calibration is not possible.	Follow the instructions given in the reference calibration routine on the FlexPendant to create reference values. Creating new values requires possibility to move the robot. Read more about reference calibration for Axis Calibration in Reference calibration routine on page 798 .
	If the robot is to be calibrated with fine calibration: Remove all external cable packages (DressPack) and tools from the robot.	

Removing the outer arm



Use these procedures to remove the outer arm.

Preparations before removing the outer arm

Remove the robot from the wall or enough space.

	Action	Note
1	Decide which calibration routine to use, and take actions accordingly prior to beginning the repair procedure.	

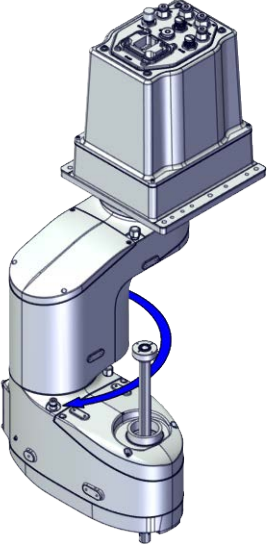
Continues on next page

	Action	Note
2	<p>If there is no enough space for the maintenance work, remove the robot from the wall and place it on the maintenance bracket.</p> <p> CAUTION</p> <p>Do not lay down the robot during the transportation, always keep it straight. If the robot lay down in any situation, the grease may come out from gearbox.</p>	
3	<p>Jog the outer arm to access the casting cover screws.</p>	 <p>xx1800003407</p>
4	<p> DANGER</p> <p>Turn off all:</p> <ul style="list-style-type: none"> • electric power supply • hydraulic pressure supply • air pressure supply <p>to the robot, before entering the safeguarded space.</p>	
5	<p> CAUTION</p> <p>For robots with protection type Clean Room Always cut the paint with a knife and grind the paint edge when disassembling parts of the robot! See Cut the paint or surface on the robot before replacing parts on page 118.</p>	



Continues on next page

5 Repair

5.6.10 Replacing the outer arm

Continued



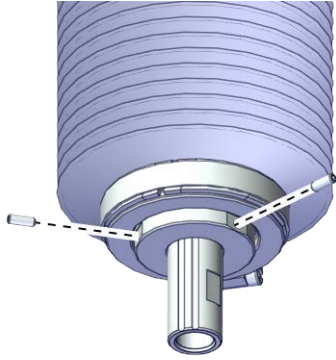
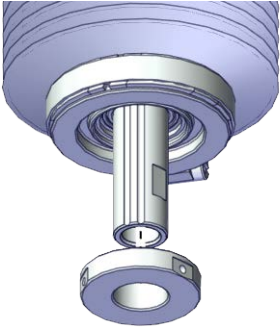

Removing the lower cover

	Action	Note
1	 DANGER Make sure that all supplies for electrical power, hydraulic pressure, and air pressure are turned off.	
2	 CAUTION For robots with protection type Clean Room Always cut the paint with a knife and grind the paint edge when disassembling parts of the robot! See Cut the paint or surface on the robot before replacing parts on page 118 .	
3	For robots with protection class IP54 (option 3350-540) For robots with protection type Clean Room (option 3351-1) Loose the locking screws.	 <small>xx1900001606</small>
4	For robots with protection class IP54 (option 3350-540) For robots with protection type Clean Room (option 3351-1) Remove the lower cover from the ball screw.	 <small>xx1900001607</small>

Removing the cover of the outer arm

	Action	Note
1	 DANGER Make sure that all supplies for electrical power, hydraulic pressure, and air pressure are turned off.	

Continues on next page

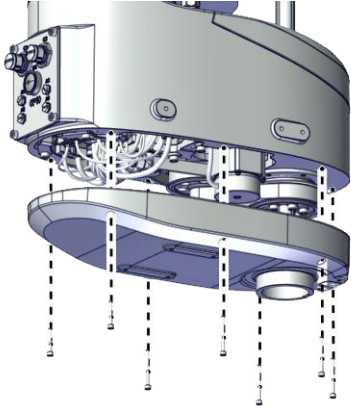
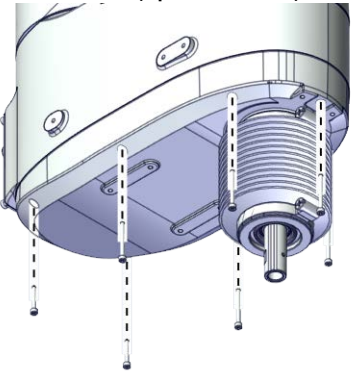
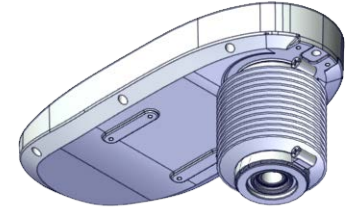
	Action	Note
2	<p> CAUTION</p> <p>For robots with protection type Clean Room Always cut the paint with a knife and grind the paint edge when disassembling parts of the robot! See <i>Cut the paint or surface on the robot before replacing parts on page 118.</i></p>	
3	<p>Remove the screws on the cover of the outer arm and remove the cover.</p> <p> Note</p> <p>For robots with protection class IP54 (option 3350-540) For robots with protection type Clean Room (option 3351-1) Remove the cover with bellow and housing.</p> <p> Note</p> <p>The bellow does not need to be removed separately.</p> <p> CAUTION</p> <p>There is a gasket in the cover. Be careful when removing the cover with bellow and housing.</p> <p> Tip</p> <p>Check the gasket and replace it if needed.</p>	<p>For robots with protection class IP30 (option 3350-300)</p>  <p>xx1800002836</p> <p>For robots with protection class IP54 (option 3350-540) For robots with protection type Clean Room (option 3351-1)</p>  <p>xx1900001631</p>  <p>xx1900001632</p>



Continues on next page

5 Repair



5.6.10 Replacing the outer arm

Continued

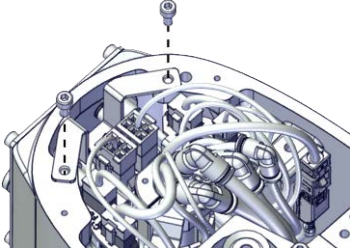
Removing the bracket for the process hub

	Action	Note
1	 DANGER Make sure that all supplies for electrical power, hydraulic pressure, and air pressure are turned off.	
2	 CAUTION For robots with protection type Clean Room Always cut the paint with a knife and grind the paint edge when disassembling parts of the robot! See Cut the paint or surface on the robot before replacing parts on page 118 .	
3	Remove the screws on the bracket and take it out carefully.	 xx1800002839

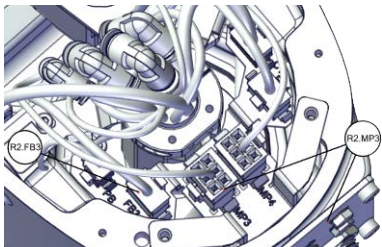

Disconnecting the connectors for axis-3 motor

	Action	Note
1	 DANGER Make sure that all supplies for electrical power, hydraulic pressure, and air pressure are turned off.	
2	 CAUTION For robots with protection type Clean Room Always cut the paint with a knife and grind the paint edge when disassembling parts of the robot! See Cut the paint or surface on the robot before replacing parts on page 118 .	
3	Disconnect the connectors. <ul style="list-style-type: none"> • R2.MP3 • R2.FB3 	 xx1900000063

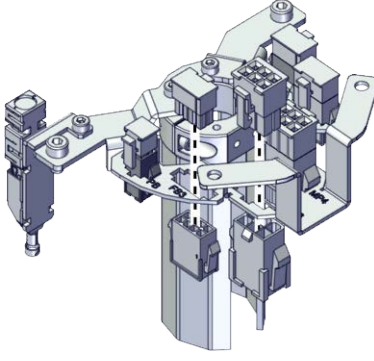
Continues on next page

	Action	Note
4	Snap loose and remove the female head of the connectors from the bracket.	 <p>xx1900000064</p>

Disconnecting the connectors for axis-4 motor

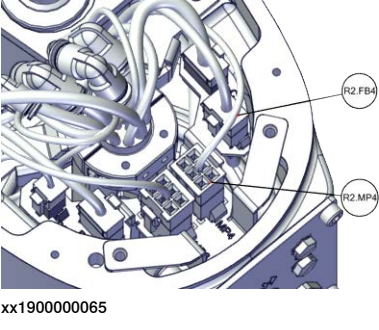
	Action	Note
1	 DANGER Make sure that all supplies for electrical power, hydraulic pressure, and air pressure are turned off.	
2	 CAUTION For robots with protection type Clean Room Always cut the paint with a knife and grind the paint edge when disassembling parts of the robot! See Cut the paint or surface on the robot before replacing parts on page 118.	
3	Disconnect the connectors. <ul style="list-style-type: none"> • R2.MP4 • R2.FB4 	 <p>xx1900000065</p>

Continues on next page



5 Repair

5.6.10 Replacing the outer arm

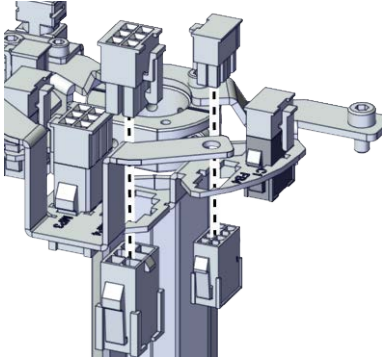
Continued

	Action	Note
4	Snap loose and remove the female head of the connectors from the bracket.	 <p>xx190000066</p>

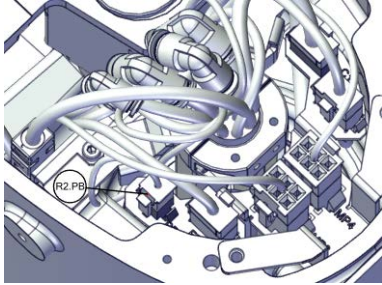

Disconnecting the connector for PB

	Action	Note
1	 DANGER Make sure that all supplies for electrical power, hydraulic pressure, and air pressure are turned off.	
2	 CAUTION For robots with protection type Clean Room Always cut the paint with a knife and grind the paint edge when disassembling parts of the robot! See Cut the paint or surface on the robot before replacing parts on page 118 .	
3	Disconnect the connector. <ul style="list-style-type: none"> R2.PB 	 <p>xx190000068</p>

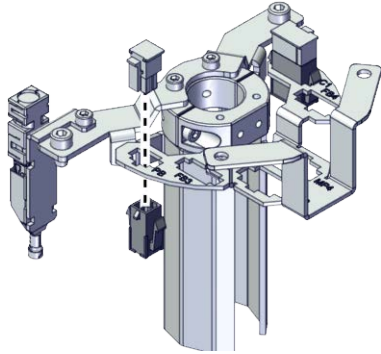
Continues on next page

	Action	Note
4	Snap loose and remove the female head of the connector from the bracket.	 <p>xx1900000069</p>

Disconnecting the air hoses, C1 cabling and C2 cabling (if equipped)

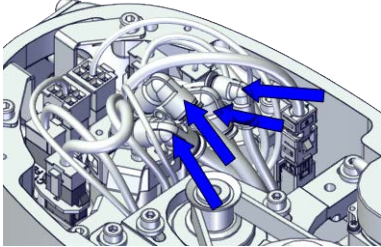



	Action	Note
1	 DANGER Make sure that all supplies for electrical power, hydraulic pressure, and air pressure are turned off.	
2	 CAUTION For robots with protection type Clean Room Always cut the paint with a knife and grind the paint edge when disassembling parts of the robot! See Cut the paint or surface on the robot before replacing parts on page 118 .	
3	Disconnect the air hoses from the L-shaped connectors.	 <p>xx1800002837</p>

Continues on next page

5 Repair

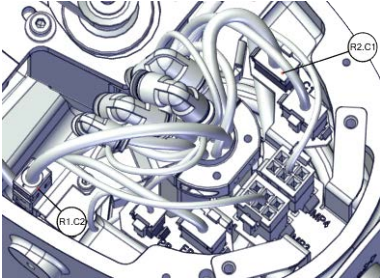

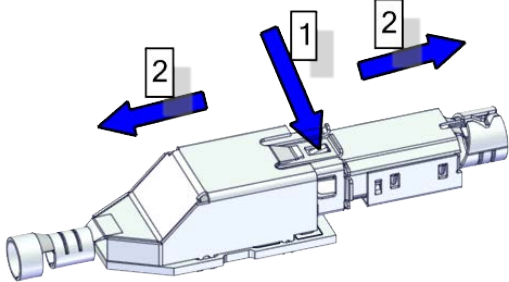
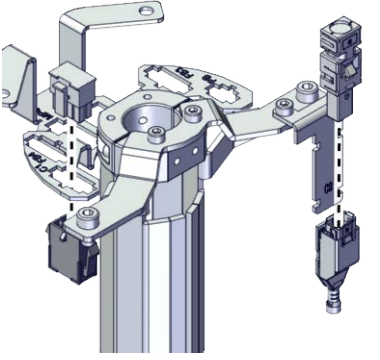
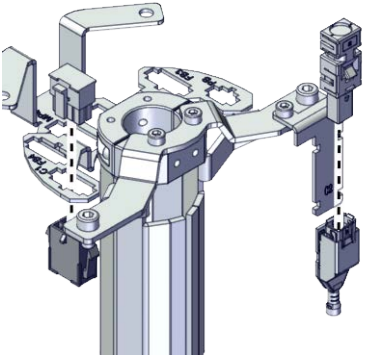

5.6.10 Replacing the outer arm

Continued

	Action	Note
4	For robots with C1 cabling Disconnect the connector. <ul style="list-style-type: none">• R2.C1	 xx1900000070
5	For robots with C2 cabling Disconnect the connector. <ul style="list-style-type: none">• R1.C2 <p> Tip</p> <p>Cut the cable straps for the R1.C2 at the same time.</p> <p> Tip</p> <p>Take photos of the connector and cable position before disconnecting them, to have as a reference when reconnecting.</p> <p> Tip</p> <p>The connector clip has to be pressed (1) and pushed forward (2) to separate the R1.C2 (for C2 cabling).</p>  xx1800002943	 xx1900000071
6	Snap loose and remove the female head of the connectors from the bracket.	 xx1900000071

Continues on next page

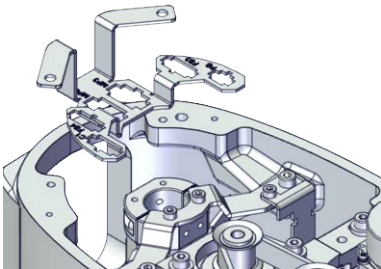
Removing the cable ferrule, bracket and protected bracket

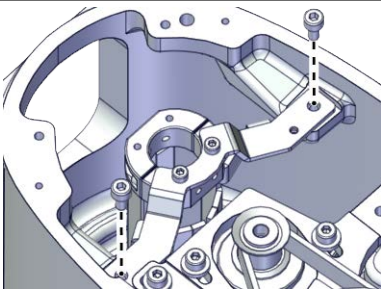

	Action	Note
1	 <p>DANGER</p> <p>Make sure that all supplies for electrical power, hydraulic pressure, and air pressure are turned off.</p>	
2	 <p>CAUTION</p> <p>For robots with protection type Clean Room Always cut the paint with a knife and grind the paint edge when disassembling parts of the robot! See Cut the paint or surface on the robot before replacing parts on page 118.</p>	
3	<p>Take out the bracket from the outer arm.</p>  <p>Note</p> <p>The harness are not visible due to the cleanness requirements of the illustration. They are still existing inside the cable ferrule in the actual situation.</p>	 <p>xx1900000073</p>
4	<p>Remove the screws on the protected bracket.</p>  <p>Note</p> <p>The harness are not visible due to the cleanness requirements of the illustration. They are still existing inside the cable ferrule in the actual situation.</p>	 <p>xx1900000074</p>

Continues on next page

5 Repair

5.6.10 Replacing the outer arm

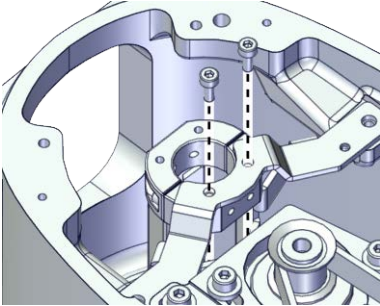
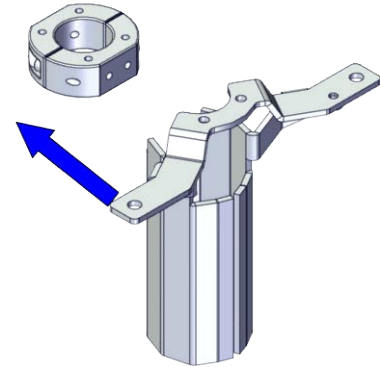

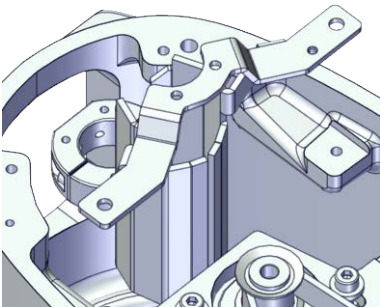
Continued

	Action	Note
5	<p>Remove the screws on the protected bracket to the cable ferrule to release the cable ferrule with cable.</p> <p> Note</p> <p>The harness are not visible due to the cleanness requirements of the illustration. They are still existing inside the cable ferrule in the actual situation.</p>	 <p>xx1900000075</p>  <p>xx1900000076</p>
6	<p>Remove the protected bracket.</p> <p> Tip</p> <p>Pull the protected bracket to the ball screw side to push the cable with the cable ferrule out from the protected bracket.</p> <p> Note</p> <p>The harness are not visible due to the cleanness requirements of the illustration. They are still existing inside the cable ferrule in the actual situation.</p>	 <p>xx1900000078</p>

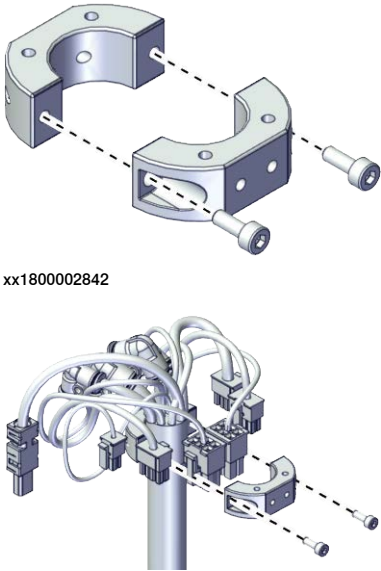
Continues on next page

	Action	Note
7	Remove the screws on the cable ferrule and take the cable ferrule out.	 <p>xx1800002842</p> <p>xx1800002849</p>

Pull out the process hub

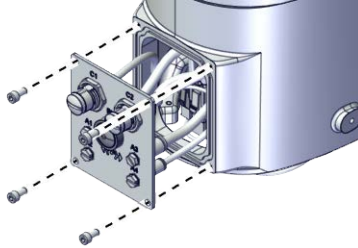
	Action	Note
1	 <p>DANGER</p> <p>Make sure that all supplies for electrical power, hydraulic pressure, and air pressure are turned off.</p>	
2	 <p>CAUTION</p> <p>For robots with protection type Clean Room Always cut the paint with a knife and grind the paint edge when disassembling parts of the robot! See Cut the paint or surface on the robot before replacing parts on page 118.</p>	
3	<p>Remove the screws and carefully pull out the process hub.</p>  <p>CAUTION</p> <p>Be aware of the cabling that is attached to the cover! The cover can not be removed completely until the connectors are disconnected, as shown in following steps.</p>	 <p>xx1800002848</p>



Continues on next page

5 Repair



5.6.10 Replacing the outer arm

Continued

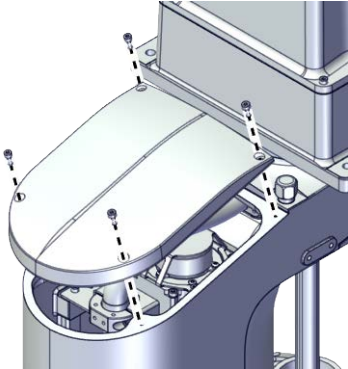

Removing the casting cover of the inner arm

	Action	Note
1	 DANGER Make sure that all supplies for electrical power, hydraulic pressure, and air pressure are turned off.	
2	 CAUTION For robots with protection type Clean Room Always cut the paint with a knife and grind the paint edge when disassembling parts of the robot! See Cut the paint or surface on the robot before replacing parts on page 118 .	
3	Remove the screws.	 xx1800002873
4	Remove the casting cover.	

Removing the cable bracket at the axis -2 motor position in the inner arm

	Action	Note
1	 DANGER Make sure that all supplies for electrical power, hydraulic pressure, and air pressure are turned off.	
2	 CAUTION For robots with protection type Clean Room Always cut the paint with a knife and grind the paint edge when disassembling parts of the robot! See Cut the paint or surface on the robot before replacing parts on page 118 .	

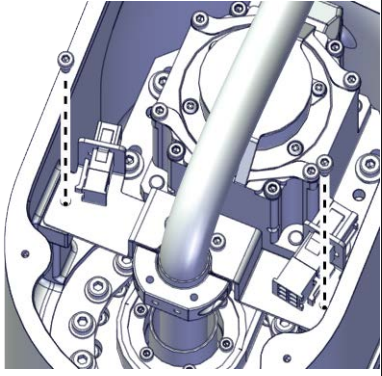
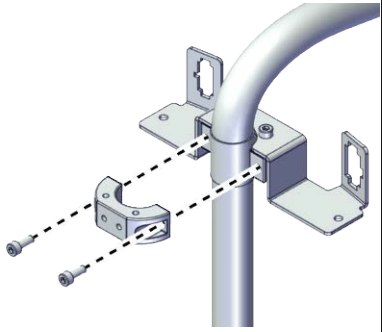
Continues on next page

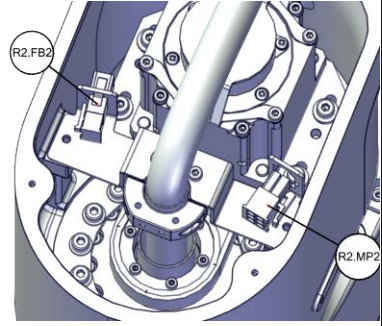
	Action	Note
3	Remove the screws.	 <p>xx1800002874</p>
4	Remove the screws on the cable ferrule to release the cable.	 <p>xx1800002876</p>
5	Disconnect the connectors. <ul style="list-style-type: none"> • R2.MP2 • R2.FB2  Tip Take photos of the connector and cable position before disconnecting them, to have as a reference when reconnecting.	 <p>xx1800002875</p>

Removing the internal harness from the axis -2 gearbox position





	Action	Note
1	 DANGER Make sure that all supplies for electrical power, hydraulic pressure, and air pressure are turned off.	

Continues on next page



5 Repair

5.6.10 Replacing the outer arm

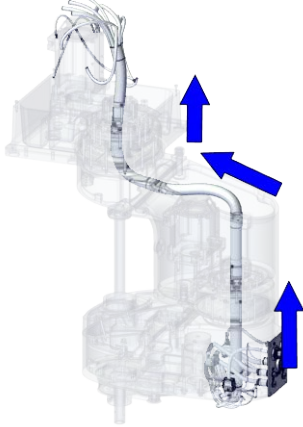
Continued



	Action	Note
2	 CAUTION For robots with protection type Clean Room Always cut the paint with a knife and grind the paint edge when disassembling parts of the robot! See Cut the paint or surface on the robot before replacing parts on page 118 .	
3	Cut the cable straps for R2.MP3 and R2.MP4.  Tip Take photos of the cable straps position before cutting them, to have as a reference when routing the cable.	
4	Pull the internal harness out of the outer arm from the centre of the axis-2 gearbox.  Tip Wrap the connectors with the masking tape.  Tip Take photos of the connector and cable position before disconnecting them, to have as a reference when reconnecting.	 xx1800003411

Removing the axis-2 motor sub-assembly

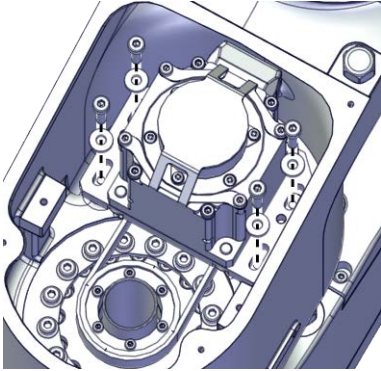

	Action	Note
1	 DANGER Make sure that all supplies for electrical power, hydraulic pressure, and air pressure are turned off.	
2	 CAUTION For robots with protection type Clean Room Always cut the paint with a knife and grind the paint edge when disassembling parts of the robot! See Cut the paint or surface on the robot before replacing parts on page 118 .	

Continues on next page

5.6.10 Replacing the outer arm
Continued

	Action	Note
3	Remove the screws and washers.	 <p>xx1800002877</p>
4	Remove the motor and the timing belt.  Tip Move the internal harness out of the way.	

Separating the outer arm from the inner arm

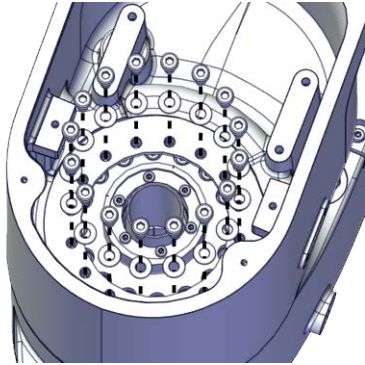
	Action	Note
1	 DANGER Make sure that all supplies for electrical power, hydraulic pressure, and air pressure are turned off.	
2	 CAUTION For robots with protection type Clean Room Always cut the paint with a knife and grind the paint edge when disassembling parts of the robot! See <i>Cut the paint or surface on the robot before replacing parts on page 118.</i>	
3	Remove the screws and washers.	 <p>xx1800003382</p>

Continues on next page



5 Repair

5.6.10 Replacing the outer arm

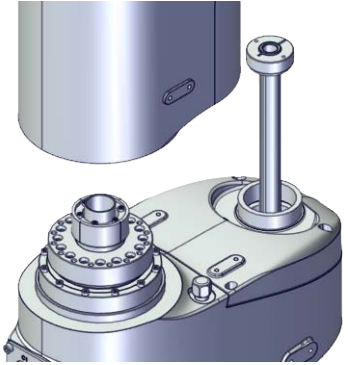

Continued

	Action	Note
4	<p>Remove the outer arm with the axis-2 gear unit assembly from the inner arm.</p> <p> Tip</p> <p>Move the internal harness out of the way.</p>	 <p>xx1800003383</p>

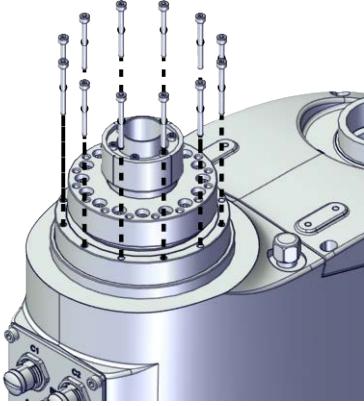

Separating the axis-2 gear unit sub-assembly from the outer arm

	Action	Note
1	<p> DANGER</p> <p>Make sure that all supplies for electrical power, hydraulic pressure, and air pressure are turned off.</p>	
2	<p> CAUTION</p> <p>For robots with protection type Clean Room</p> <p>Always cut the paint with a knife and grind the paint edge when disassembling parts of the robot!</p> <p>See Cut the paint or surface on the robot before replacing parts on page 118.</p>	
3	<p>Remove the screws and washers.</p>	 <p>xx1800003384</p>

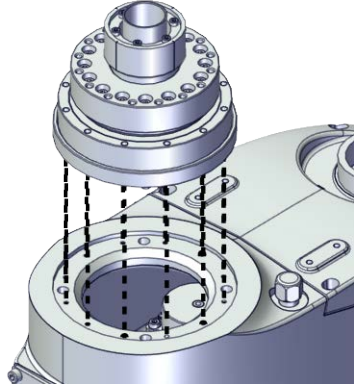
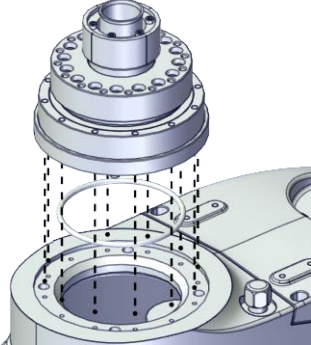
Continues on next page

	Action	Note
4	<p>Remove the gear unit.</p> <p> Note</p> <p>For robots with protection class IP54 (option 3350-540)</p> <p>For robots with protection type Clean Room (option 3351-1)</p> <p>Remove the gear unit sub-assembly and the O-ring.</p> <p> Tip</p> <p>Check the O-ring and replace it if needed.</p> <p> Tip</p> <p>Move the internal harness out of the way.</p>	<p>For robots with protection class IP30 (option 3350-300)</p>  <p>xx1800003385</p> <p>For robots with protection class IP54 (option 3350-540)</p> <p>For robots with protection type Clean Room (option 3351-1)</p>  <p>xx1900001645</p>

Removing the pulley pre-assembly with the motor

	Action	Note
1	<p> DANGER</p> <p>Make sure that all supplies for electrical power, hydraulic pressure, and air pressure are turned off.</p>	
2	<p> CAUTION</p> <p>For robots with protection type Clean Room</p> <p>Always cut the paint with a knife and grind the paint edge when disassembling parts of the robot!</p> <p>See Cut the paint or surface on the robot before replacing parts on page 118.</p>	

Continues on next page



5 Repair

5.6.10 Replacing the outer arm

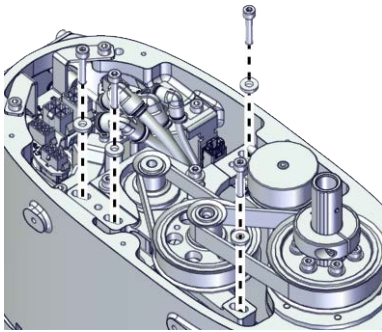
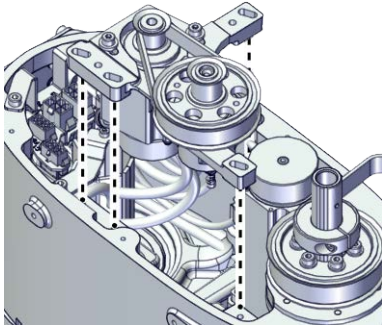
Continued

	Action	Note
3	 DANGER Make sure that the ball screw is supported with something. The sudden drop of the ball screw due the lost of the axis-4 motor may cause danger.	
4	Remove the screws.	 xx1800002888
5	Remove the pulley pre-assembly and the timing belt.	 xx1800002889



Removing the upper cover

	Action	Note
1	 DANGER Make sure that all supplies for electrical power, hydraulic pressure, and air pressure are turned off.	
2	 CAUTION For robots with protection type Clean Room Always cut the paint with a knife and grind the paint edge when disassembling parts of the robot! See Cut the paint or surface on the robot before replacing parts on page 118.	

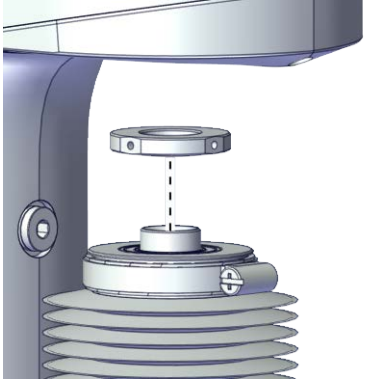
Continues on next page

	Action	Note
3	<p>For robots with protection class IP54 (option 3350-540) For robots with protection type Clean Room (option 3351-1) Loose the locking screws.</p>	 <p>xx1900001547</p>
4	<p>For robots with protection class IP54 (option 3350-540) For robots with protection type Clean Room (option 3351-1) Remove the upper cover from the ball screw.</p>	 <p>xx1900001548</p>

Removing the casting cover of the outer arm





	Action	Note
1	<p> DANGER Make sure that all supplies for electrical power, hydraulic pressure, and air pressure are turned off.</p>	
2	<p> CAUTION For robots with protection type Clean Room Always cut the paint with a knife and grind the paint edge when disassembling parts of the robot! See Cut the paint or surface on the robot before replacing parts on page 118.</p>	

Continues on next page

5 Repair

5.6.10 Replacing the outer arm

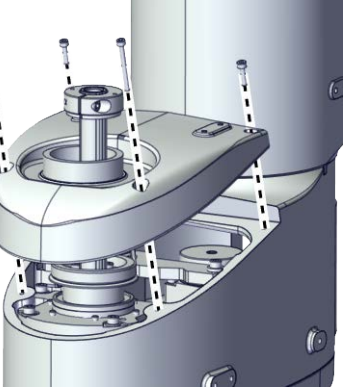
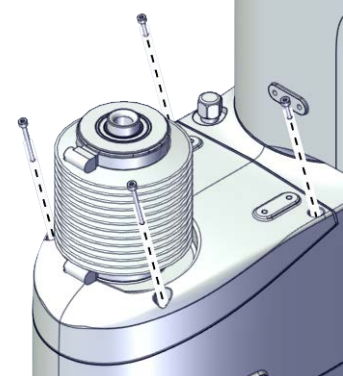
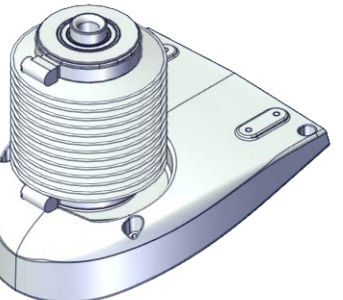

Continued

	Action	Note
3	<p>Remove the screws on the casting cover of the outer arm and remove the cover.</p> <p> Note</p> <p>For robots with protection class IP54 (option 3350-540) For robots with protection type Clean Room (option 3351-1) Remove the cover with bellow and housing.</p> <p> Note</p> <p>The bellow does not need to be removed separately.</p> <p> CAUTION</p> <p>There is a gasket in the cover. Be careful when removing the cover with bellow and housing.</p> <p> Tip</p> <p>Check the gasket and replace it if needed.</p>	<p>For robots with protection class IP30 (option 3350-300)</p>  <p>xx1800002883</p> <p>For robots with protection class IP54 (option 3350-540) For robots with protection type Clean Room (option 3351-1)</p>  <p>xx1900001628</p>  <p>xx1900001629</p>

Removing the axis-3 motor sub-assembly

	Action	Note
1	<p> DANGER</p> <p>Make sure that all supplies for electrical power, hydraulic pressure, and air pressure are turned off.</p>	

Continues on next page

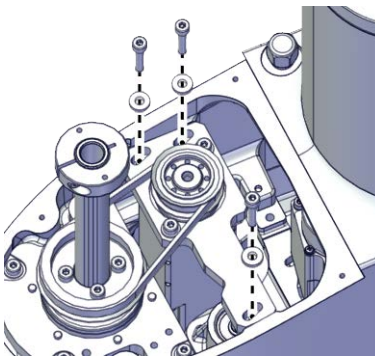
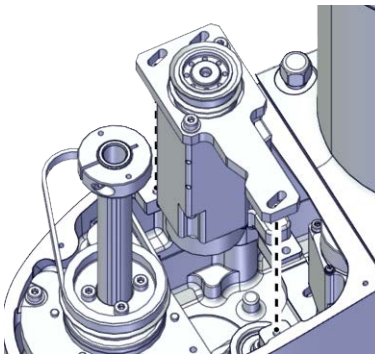
	Action	Note
2	<p> CAUTION</p> <p>For robots with protection type Clean Room Always cut the paint with a knife and grind the paint edge when disassembling parts of the robot! See <i>Cut the paint or surface on the robot before replacing parts on page 118.</i></p>	
3	<p> DANGER</p> <p>Make sure that the ball screw is supported with something. The sudden drop of the ball screw due the lost of the axis-3 motor may cause danger.</p>	
4	Remove the screws.	 <p>xx1800002884</p>
5	Remove the axis-3 motor sub-assembly and the timing belt.	 <p>xx1800002885</p>

Removing the shaft for Clean Room/ IP54 robots



	Action	Note
1	<p> DANGER</p> <p>Make sure that all supplies for electrical power, hydraulic pressure, and air pressure are turned off.</p>	

Continues on next page

5 Repair

5.6.10 Replacing the outer arm

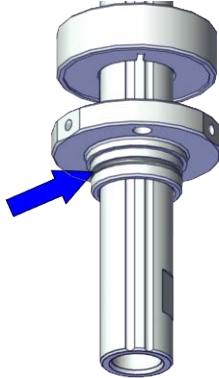
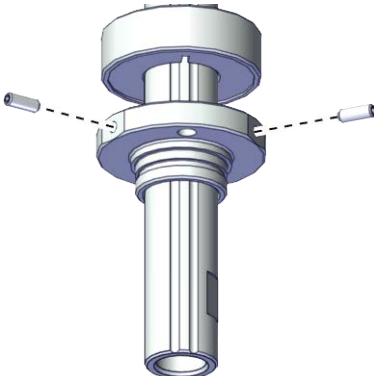

Continued

	Action	Note
2	 CAUTION For robots with protection type Clean Room Always cut the paint with a knife and grind the paint edge when disassembling parts of the robot! See Cut the paint or surface on the robot before replacing parts on page 118 .	
3	For robots with protection class IP54 (option 3350-540) For robots with protection type Clean Room (option 3351-1) Remove the O-ring from the lower housing.	 xx1900001615
4	For robots with protection class IP54 (option 3350-540) For robots with protection type Clean Room (option 3351-1) Loosen the attachment screws.	 xx1900001616
5	For robots with protection class IP54 (option 3350-540) For robots with protection type Clean Room (option 3351-1) Remove the shaft from the mechanical stopper.  Note The shaft is glued to the ball screw. Be careful with the glue when removing the shaft.	

Removing the lower mechanical stopper

	Action	Note
1	 DANGER Make sure that all supplies for electrical power, hydraulic pressure, and air pressure are turned off.	

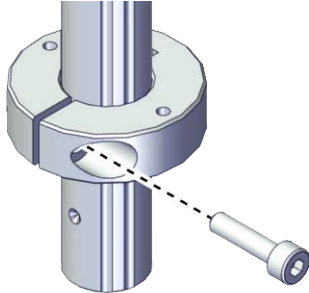
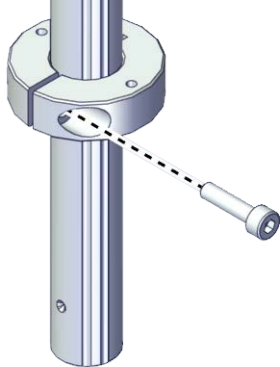
Continues on next page

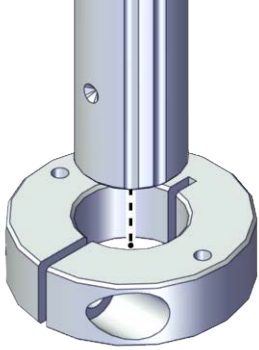
	Action	Note
2	<p> CAUTION</p> <p>For robots with protection type Clean Room Always cut the paint with a knife and grind the paint edge when disassembling parts of the robot! See <i>Cut the paint or surface on the robot before replacing parts on page 118.</i></p>	
3	Remove the screw.	<p>For robots with protection class IP30 (option 3350-300)</p>  <p>xx1800002860</p> <p>For robots with protection class IP54 (option 3350-540) For robots with protection type Clean Room (option 3351-1)</p>  <p>xx1900001642</p>
4	<p>Remove the mechanical stopper.</p> <p> CAUTION</p> <p>If the ball screw nut or ball screw spline nut go out of the screw shaft, the ball screw is destroyed. Be careful when you do any work that may cause this.</p>	 <p>xx1800002861</p>





Continues on next page

5 Repair

5.6.10 Replacing the outer arm

Continued

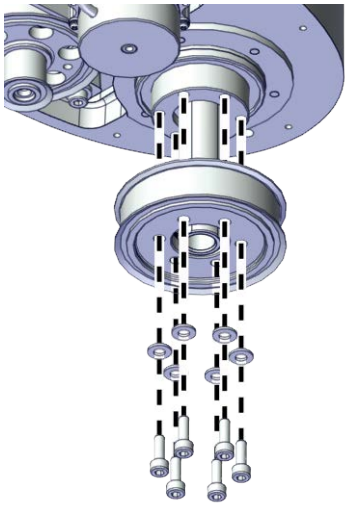
Removing the pulley on the ball screw lower position







	Action	Note
1	 DANGER Make sure that all supplies for electrical power, hydraulic pressure, and air pressure are turned off.	
2	 ELECTROSTATIC DISCHARGE (ESD) The unit is sensitive to ESD. Before handling the unit read the safety information in section The unit is sensitive to ESD on page 45 .	
3	 CAUTION For robots with protection type Clean Room Always cut the paint with a knife and grind the paint edge when disassembling parts of the robot! See Cut the paint or surface on the robot before replacing parts on page 118 .	
4	Remove the screws and washers.	
5	Remove the pulley carefully.  CAUTION If the ball screw nut or ball screw spline nut go out of the screw shaft, the ball screw is destroyed. Be careful when you do any work that may cause this.	

xx1800002865

Removing the ball screw assembly

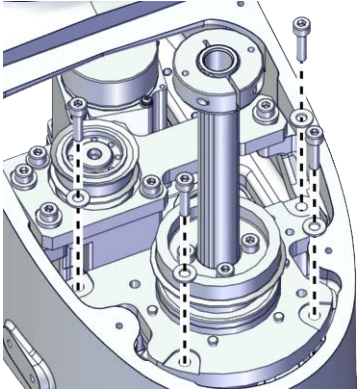
	Action	Note
1	 DANGER Make sure that all supplies for electrical power, hydraulic pressure, and air pressure are turned off.	

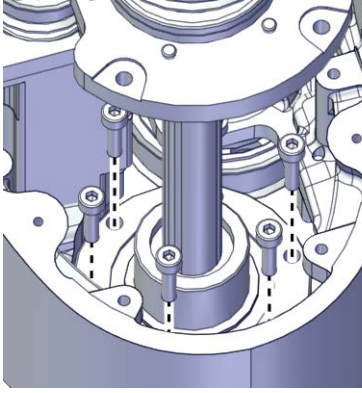
Continues on next page

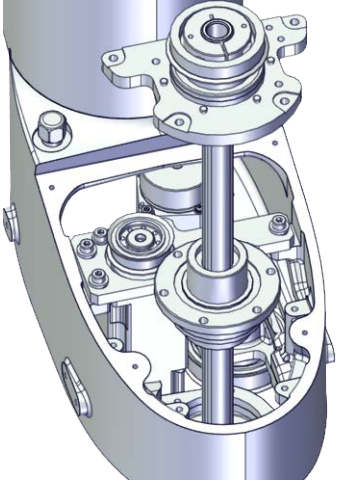
	Action	Note
2	<p> CAUTION</p> <p>For robots with protection type Clean Room Always cut the paint with a knife and grind the paint edge when disassembling parts of the robot! See <i>Cut the paint or surface on the robot before replacing parts on page 118.</i></p>	
3	<p>Remove the screws and washers on the adaptor to the outer arm.</p> <p> Tip</p> <p>Hold the ball screw to prevent it from dropping. Or the ball screw may be destroyed.</p>	 <p>xx1800003393</p>
4	<p>Raise the upper part of the ball screw with the adaptor and remove the screws on the lower part of the ball screw to the outer arm.</p> <p> Tip</p> <p>Hold the ball screw to prevent it from dropping. Or the ball screw may be destroyed.</p>	 <p>xx1800003394</p>
5	<p>Remove the ball screw assembly from the outer arm carefully.</p> <p> Tip</p> <p>Hold the lower part of the ball screw to prevent it from dropping. Or the ball screw may be destroyed.</p> <p> CAUTION</p> <p>If the ball screw nut or ball screw spline nut go out of the screw shaft, the ball screw is destroyed. Be careful when you do any work that may cause this.</p>	 <p>xx1800003395</p>

Continues on next page

5 Repair

5.6.10 Replacing the outer arm



Continued

	Action	Note
6	<p>Lay down the ball screw assembly.</p> <p> CAUTION</p> <p>If the ball screw nut or ball screw spline nut go out of the screw shaft, the ball screw is destroyed. Be careful when you do any work that may cause this.</p>	

Refitting the outer arm

Use these procedures to refit the outer arm.

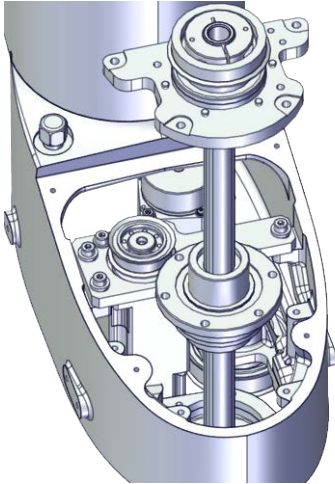

Refitting the ball screw assembly

	Action	Note
1	<p>For robots with protection type Clean Room: Clean the joints that have been opened and wipe the parts free from particles with spirit on a lint free. See Cut the paint or surface on the robot before replacing parts on page 118</p> <p> Note</p> <p>After all repair work, wipe the Clean Room robot free from particles with spirit on a lint free cloth.</p>	
2	<p>Refit the ball screw assembly to the outer arm.</p> <p> Tip</p> <p>Hold the lower part of the ball screw to prevent it from dropping. Or the ball screw may be destroyed.</p> <p> CAUTION</p> <p>If the ball screw nut or ball screw spline nut go out of the screw shaft, the ball screw is destroyed. Be careful when you do any work that may cause this.</p>	 <p>xx1800003395</p>

Continues on next page

5.6.10 Replacing the outer arm

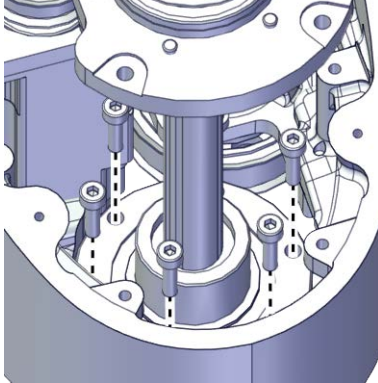
Continued

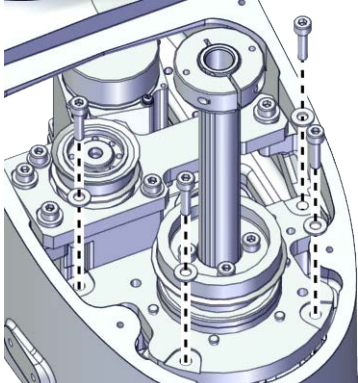
	Action	Note
3	<p>Refit the screws to secure the lower part of the ball screw to the outer arm.</p>	<p>Screws: Hex socket head cap screw M4x16 12.9 Lafre 2C2B/FC6.9 (6 pcs) Tightening torque: 3.8 Nm ±10%</p>  <p>xx1800003394</p>
4	<p>Refit the screws and washers to secure the adaptor on the ball screw to the outer arm.</p> <p> Tip</p> <p>Pre-tighten the screws at 0.5Nm and slide the ball screw up and down for five times. Then tighten the screws at 3.8Nm to secure it.</p>	<p>Screws: Hex socket head cap screw M4x16 12.9 Lafre 2C2B/FC6.9 (6 pcs) Washers: Spring washer 9x4.3x1 Steel (6 pcs) Tightening torque: 0.5 Nm-3.8 Nm ±10%</p>  <p>xx1800003393</p>

Refitting the pulley on the ball screw lower position



	Action	Note
1	<p> ELECTROSTATIC DISCHARGE (ESD)</p> <p>The unit is sensitive to ESD. Before handling the unit read the safety information in section The unit is sensitive to ESD on page 45.</p>	

Continues on next page

5 Repair

5.6.10 Replacing the outer arm

Continued

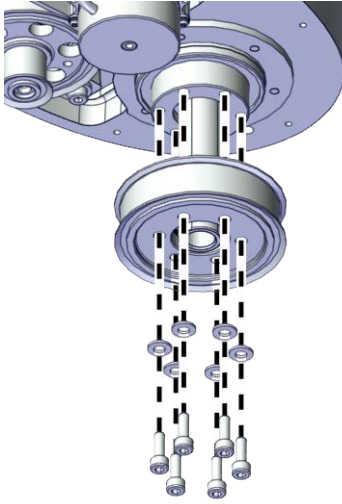
	Action	Note
2	<p>For robots with protection type Clean Room: Clean the joints that have been opened and wipe the parts free from particles with spirit on a lint free. See Cut the paint or surface on the robot before replacing parts on page 118</p> <p> Note</p> <p>After all repair work, wipe the Clean Room robot free from particles with spirit on a lint free cloth.</p>	
3	<p>Refit the pulley to the ball screw carefully.</p> <p> CAUTION</p> <p>If the ball screw nut or ball screw spline nut go out of the screw shaft, the ball screw is destroyed. Be careful when you do any work that may cause this.</p>	<p>For IRB 910INV-3/0.35: Screws: Hex socket head cap screw M4x12 12.9 Lafre 2C2B/FC6.9 (6 pcs) Washers: Spring washer 9x4.3x1 Steel (6 pcs) Tightening torque: 3.8 Nm \pm10%</p> <p>For IRB 910INV-6/0.55:</p>
4	<p>Refit the screws.</p> <p> Tip</p> <p>Secure with the special stopping tool to prevent the pulley from rotating.</p>	<p>Screws: Hex socket head cap screw M5x12 12.9 Lafre 2C2B/FC6.9 (6 pcs) Washers: Plain washer 11x5.3x1.2 Steel (6 pcs) Tightening torque: 6.5 Nm \pm10%</p>  <p>xx1800002865</p>

Continues on next page

Refitting the mechanical stopper





	Action	Note
1	<p>For robots with protection type Clean Room: Clean the joints that have been opened and wipe the parts free from particles with spirit on a lint free. See Cut the paint or surface on the robot before replacing parts on page 118</p> <p> Note</p> <p>After all repair work, wipe the Clean Room robot free from particles with spirit on a lint free cloth.</p>	

Continues on next page

5 Repair

5.6.10 Replacing the outer arm

Continued

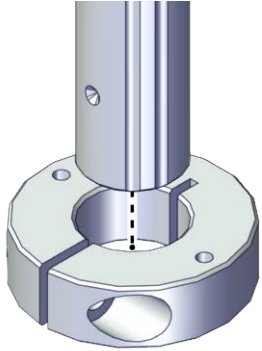
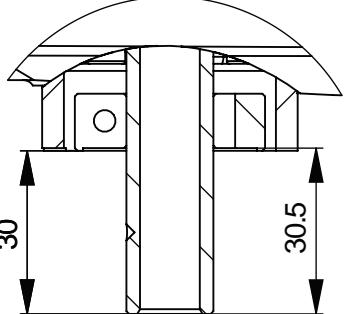
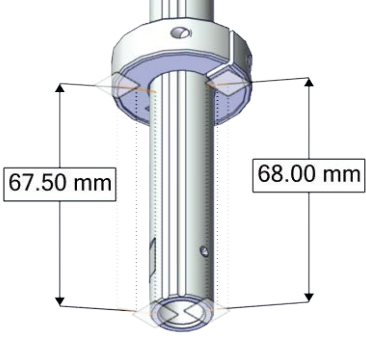
	Action	Note
2	<p>Refit the mechanical stopper to the ball screw at 30.5 mm position to the lower of the ball screw.</p> <p> Note</p> <p>For robots with protection class IP54 (option 3350-540) For robots with protection type Clean Room (option 3351-1) For IRB 910INV-3/0.35, refit the mechanical stopper to the ball screw at 68 mm position to the lower of the ball screw. For IRB 910INV-6/0.55, refit the mechanical stopper to the ball screw at 75.8 mm position to the lower of the ball screw.</p> <p> Tip</p> <p>Make sure that the limit block opening gap is aligned with the ball screw origin point.</p> <p> CAUTION</p> <p>If the ball screw nut or ball screw spline nut go out of the screw shaft, the ball screw is destroyed. Be careful when you do any work that may cause this.</p> <p> Note</p> <p>Be careful with the orientation of the mechanical stopper. The flat side is on the upper side.</p>	 <p>xx1800002861</p> <p>For robots with protection class IP30 (option 3350-300)</p>  <p>xx1900000144</p> <p>For robots with protection class IP54 (option 3350-540) For robots with protection type Clean Room (option 3351-1) For IRB 910INV-3/0.35</p>  <p>xx1900001641</p> <p>For IRB 910INV-6/0.55</p>

Continues on next page

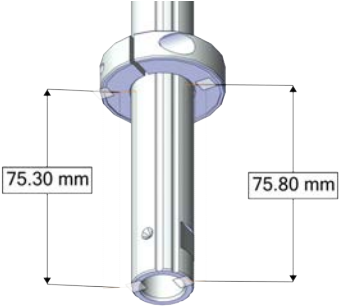
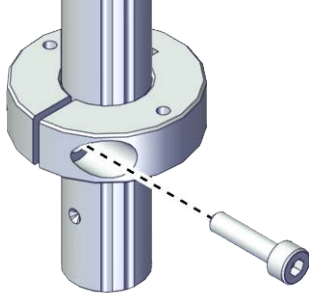
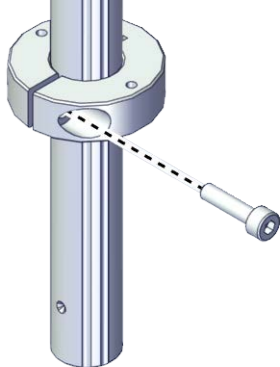
	Action	Note
		 <p>xx1900002004</p>
3	Refit the screw.	<p>Screws: Hex socket head cap screw M4x16 12.9 Lafre 2C2B/FC6.9 (1 pcs) Tightening torque: 6.5 Nm ±10% For robots with protection class IP30 (option 3350-300)</p>  <p>xx1800002860</p> <p>For robots with protection class IP54 (option 3350-540) For robots with protection type Clean Room (option 3351-1)</p>  <p>xx1900001642</p>

Continues on next page

5 Repair

5.6.10 Replacing the outer arm

Continued

Refitting the shaft for Clean Room/ IP54 robots

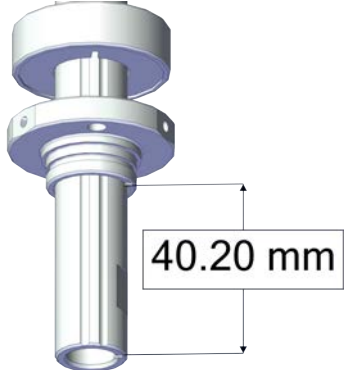
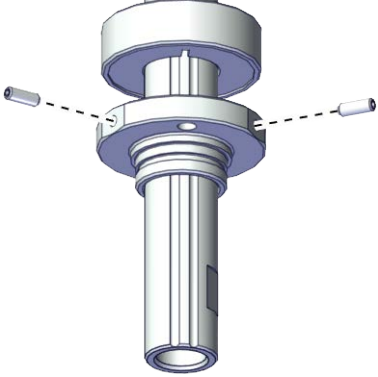

	Action	Note
1	<p>For robots with protection type Clean Room: Clean the joints that have been opened and wipe the parts free from particles with spirit on a lint free. See Cut the paint or surface on the robot before replacing parts on page 118</p> <p> Note</p> <p>After all repair work, wipe the Clean Room robot free from particles with spirit on a lint free cloth.</p>	
2	<p>For robots with protection class IP54 (option 3350-540) For robots with protection type Clean Room (option 3351-1) Install the shaft to the ball screw at 40.2 mm position to the lower of the ball screw.</p>	 <p>xx1900001617</p>
3	<p>For robots with protection class IP54 (option 3350-540) For robots with protection type Clean Room (option 3351-1) Secure the shaft to the ball screw with the screws.</p>	<p>Screws: Hexagon socket set screws with flat point, ISO 4026 stainless steel M3x8 (2 pcs) Tightening torque: 1.2 Nm \pm10%</p>  <p>xx1900001616</p>

Continues on next page

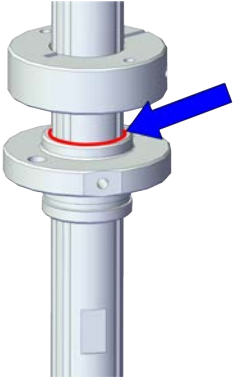
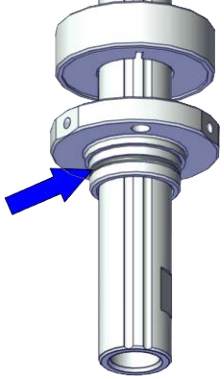
5.6.10 Replacing the outer arm
Continued

	Action	Note
4	<p>For robots with protection class IP54 (option 3350-540)</p> <p>Apply the glue to the upper contacted zone between the shaft and the ball screw.</p> <p> Note</p> <p>Fulfill the gaps on the ball screw in this contacted zone to make a sealing structure.</p>	 <p>xx1900001805</p>
5	<p>For robots with protection class IP54 (option 3350-540)</p> <p>For robots with protection type Clean Room (option 3351-1)</p> <p>Insert the O-ring to the shaft.</p>	 <p>xx1900001615</p>

Refitting the axis-3 motor sub-assembly

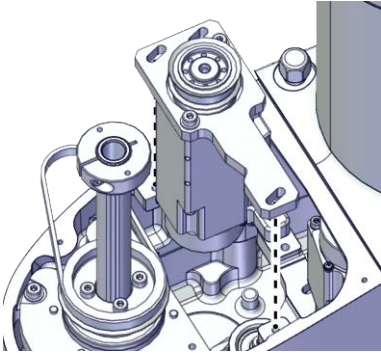
	Action	Note
1	<p>For robots with protection type Clean Room:</p> <p>Clean the joints that have been opened and wipe the parts free from particles with spirit on a lint free. See Cut the paint or surface on the robot before replacing parts on page 118</p> <p> Note</p> <p>After all repair work, wipe the Clean Room robot free from particles with spirit on a lint free cloth.</p>	
2	<p>Refit the motor to the outer arm.</p> <p> Tip</p> <p>Move the internal harness out of the way.</p>	 <p>xx1800002885</p>

Continues on next page

5 Repair

5.6.10 Replacing the outer arm

Continued

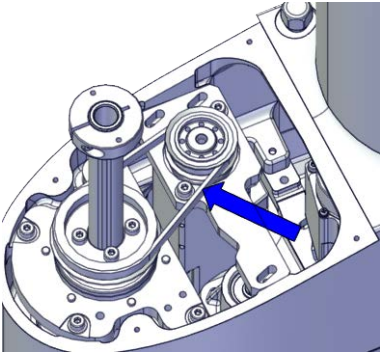
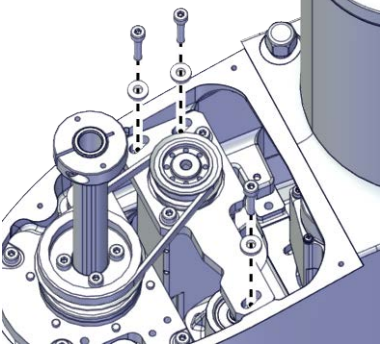
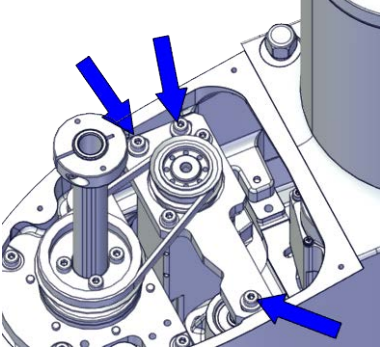
	Action	Note
3	Refit the timing belt to the pulley on the ball screw and the motor. Ensure that the belt runs correctly in the grooves.	<p>Timing belt: 3HAC061862-001</p>  <p>xx1800002886</p>
4	Refit the screws and washers.	<p>Screws: Hex socket head cap screw M4x20 12.9 Lafre 2C2B/FC6.9 (3 pcs) Washers: Washer 4.3x10x2 steel (3 pcs) Tightening torque: 3 Nm \pm10%</p>  <p>xx1800002884</p>
5	Use a sonic tension meter to measure the timing belt tension.	<p>Used belt: 190-232Hz New belt: 225-287Hz</p>
6	If the timing belt tension does not meet the requirement, loosen the motor screws and readjust.	 <p>xx1800002887</p>

Continues on next page

Refitting the pulley pre-assembly with the motor

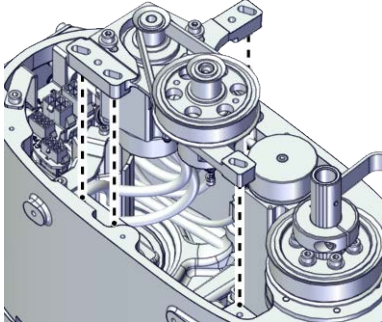
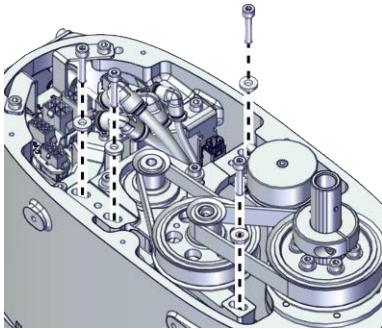
	Action	Note
1	<p>For robots with protection type Clean Room: Clean the joints that have been opened and wipe the parts free from particles with spirit on a lint free. See Cut the paint or surface on the robot before replacing parts on page 118</p> <p> Note</p> <p>After all repair work, wipe the Clean Room robot free from particles with spirit on a lint free cloth.</p>	
2	<p>Refit the pulley pre-assembly with the motor to the outer arm.</p>	<p>Screws: Hex socket head cap screw M4x20 12.9 Lafre 2C2B/FC6.9 (4 pcs) Washers: Washer 4.3x10x2 steel (4 pcs) Tightening torque: 3 Nm ±10%</p>  <p>xx1800002889</p>
3	<p>Secure with the screws.</p>	 <p>xx1800002888</p>



Continues on next page

5 Repair

5.6.10 Replacing the outer arm

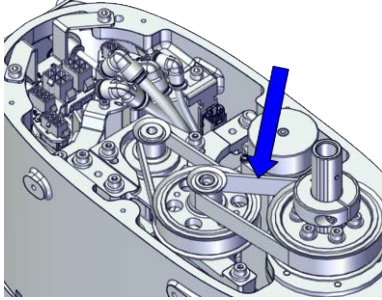

Continued

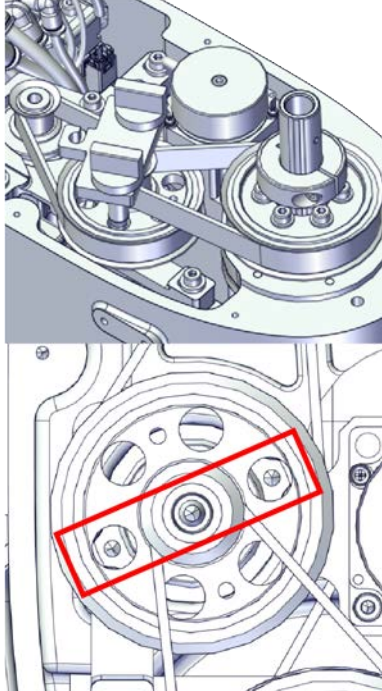
Refitting the axis-4 second timing belt

	Action	Note
1	<p>For robots with protection type Clean Room: Clean the joints that have been opened and wipe the parts free from particles with spirit on a lint free. See Cut the paint or surface on the robot before replacing parts on page 118</p> <p> Note</p> <p>After all repair work, wipe the Clean Room robot free from particles with spirit on a lint free cloth.</p>	
2	<p>Refit the timing belt to the pulley and the motor. Ensure that the belt runs correctly in the grooves.</p>	 <p>xx1800002895</p> <p>Timing belt: 3HAC061864-001</p>
3	<p>Install the axis-4 belt tension adjustment tool to the motor.</p> <p> Note</p> <p>Just tighten the tool.</p>	<p>Belt tension adjustment tool set, stage two of axis 4:-</p>  <p>xx1900000096</p>

Continues on next page

5.6.10 Replacing the outer arm
Continued

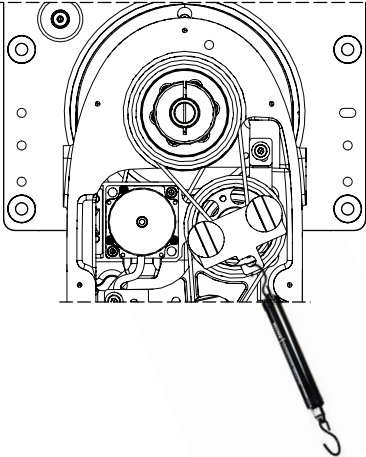
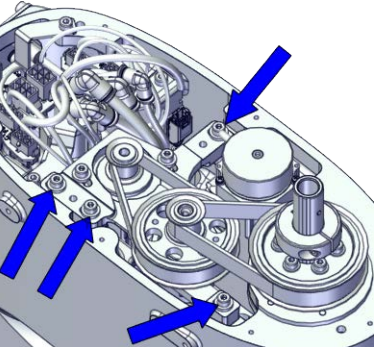
	Action	Note
4	<p>Use a handheld dynamometer hooking to the screw and pull the dynamometer to make the tension falling in the allowed force range.</p> <p> Note</p> <p>During the measurement, make sure that all interferences that may affect the force are removed. Pay attention to the force application direction.</p> <p> Tip</p> <p>If the ball screw will interfere with the handheld dynamometer, adjust the ball screw manually.</p>	<p>Used belt: 84-96N New belt:120-132N</p>  <p>xx190000097</p>
5	<p>Fasten the screws to the recommended tightening torque.</p>	<p>Tightening torque: 3 Nm ±10%</p>  <p>xx1800003389</p>
6	<p>Use a sonic tension meter to measure the timing belt tension.</p>	<p>Used belt: 257-314Hz New belt:304-389Hz</p>
7	<p>If the timing belt tension does not meet the requirement, loosen the motor screws and readjust.</p>	
8	<p>Remove the axis-4 belt tension adjustment tool.</p>	

Refitting the axis-2 gear unit sub-assembly to the outer arm





	Action	Note
1	<p>For robots with protection type Clean Room: Clean the joints that have been opened and wipe the parts free from particles with spirit on a lint free. See Cut the paint or surface on the robot before replacing parts on page 118</p> <p> Note</p> <p>After all repair work, wipe the Clean Room robot free from particles with spirit on a lint free cloth.</p>	

Continues on next page

5 Repair

5.6.10 Replacing the outer arm

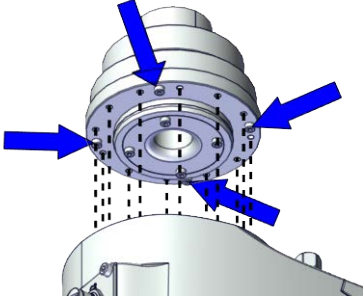
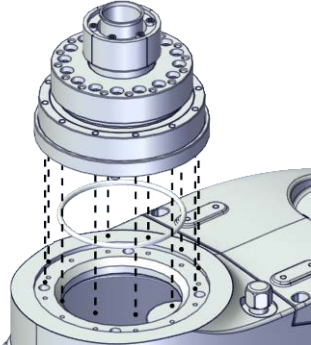

Continued

	Action	Note
2	<p> CAUTION</p> <p>Whenever parting/mating motor and gearbox, the gears may be damaged if excessive force is used.</p>	
3	<p>Refit the gear unit according to the location pin.</p> <p> Note</p> <p>For robots with protection class IP54 (option 3350-540)</p> <p>For robots with protection type Clean Room (option 3351-1)</p> <p>Refit the gear unit and the O-ring according to the location pin.</p> <p> Tip</p> <p>Check the O-ring and replace it if needed.</p> <p> Tip</p> <p>When the gear unit is in the right position, you can hear a clear "Click".</p>	<p>For robots with protection class IP30 (option 3350-300)</p>  <p>xx1800003386</p> <p>For robots with protection class IP54 (option 3350-540)</p> <p>For robots with protection type Clean Room (option 3351-1)</p>  <p>xx1900001645</p>

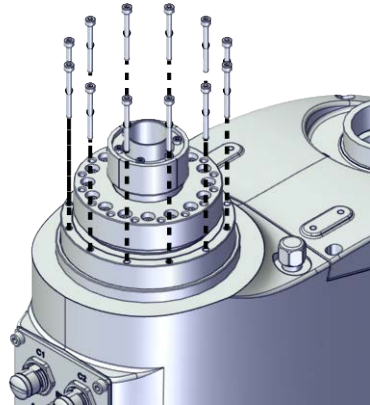
Continues on next page

	Action	Note
4	Refit the screws.	<p>Screws: Hex socket head cap screw M3x30 12.9 Lafre 2C2B/FC6.9 (12 pcs) Tightening torque: 0.5 Nm-1 Nm-1.8 Nm ±10%</p>  <p>xx1800003384</p>

Refitting the outer arm to the inner arm

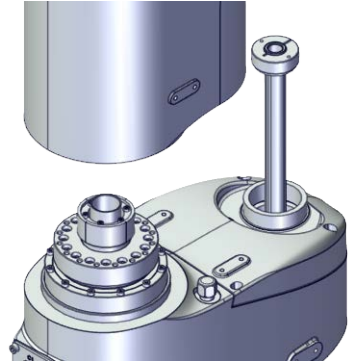
	Action	Note
1	<p>For robots with protection type Clean Room: Clean the joints that have been opened and wipe the parts free from particles with spirit on a lint free. See Cut the paint or surface on the robot before replacing parts on page 118</p> <p> Note</p> <p>After all repair work, wipe the Clean Room robot free from particles with spirit on a lint free cloth.</p>	
2	<p> CAUTION</p> <p>Whenever parting/mating motor and gearbox, the gears may be damaged if excessive force is used.</p>	
3	<p>Refit the outer arm with the gear unit to the inner arm. (Location pin?)</p> <p> Tip</p> <p>When the gear unit is in the right position, you can hear a clear "Click".</p>	 <p>xx1800003383</p>

Continues on next page



5 Repair

5.6.10 Replacing the outer arm

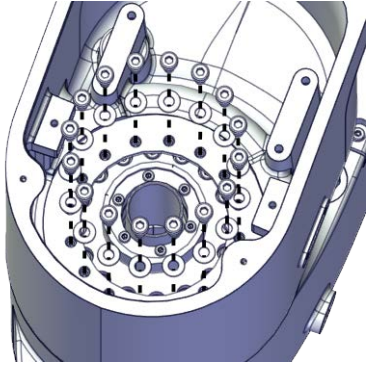

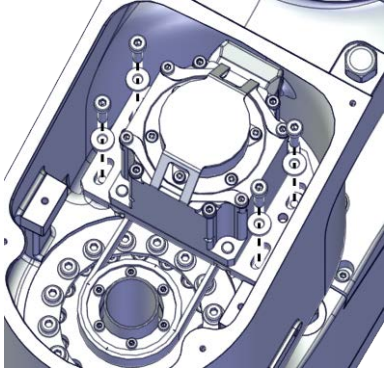

Continued

	Action	Note
4	Refit the screws.	<p>Screws: Hex socket head cap screw M4x12 12.9 Lafre 2C2B/FC6.9 (16 pcs)</p> <p>Washers: Spring washer 9x4.3x1 Steel (16 pcs)</p> <p>Tightening torque: 0.5 Nm-1 Nm-2 Nm-4.5 Nm $\pm 10\%$</p>  <p>xx1800003382</p>

Refitting the axis-2 motor sub-assembly

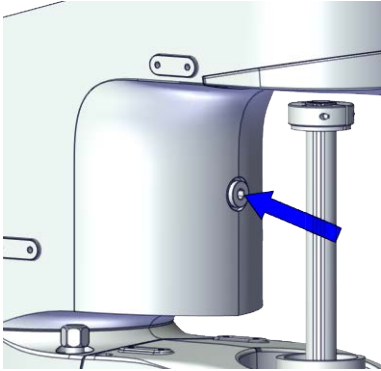
	Action	Note
1	<p>For robots with protection type Clean Room: Clean the joints that have been opened and wipe the parts free from particles with spirit on a lint free. See Cut the paint or surface on the robot before replacing parts on page 118</p> <p> Note</p> <p>After all repair work, wipe the Clean Room robot free from particles with spirit on a lint free cloth.</p>	
2	Refit the axis-2 timing belt onto the pulley on the axis-2 gearbox.	<p>Screws: Hex socket head cap screw M4x20 12.9 Lafre 2C2B/FC6.9 (4 pcs)</p> <p>Washers: Washer 4.3x10x2 steel (4 pcs)</p> <p>Tightening torque: 3 Nm $\pm 10\%$</p>  <p>xx1800002877</p> <p>Timing belt: 3HAC061861-001</p>
3	<p>Refit the motor and refit the timing belt to the motor.</p> <p>Ensure that the belt runs correctly in the grooves.</p> <p> Tip</p> <p>Move the internal harness out of the way.</p>	
4	Refit the screws and washers without fully tightened.	

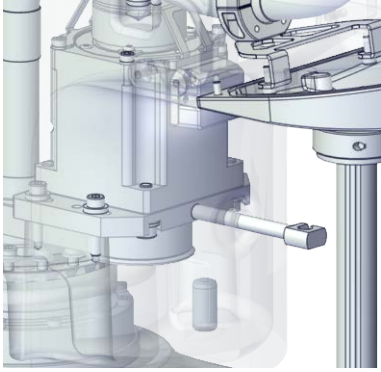
Continues on next page

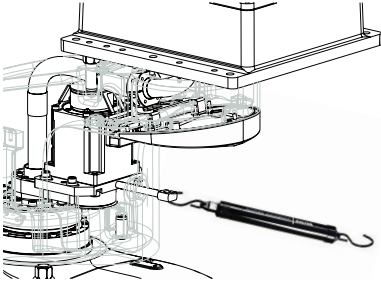

	Action	Note
5	Remove the plug.	 <p>xx1800002878</p>
6	Install the axis-1&2 belt tension adjustment tool to the motor through the hole.  Note Just tighten the tool.	Belt tension adjustment tool set, axis 1&2:-  <p>xx1800002879</p>
7	Use a handheld dynamometer hooking to the screw and pull the dynamometer to make the tension falling in the allowed force range.  Note During the measurement, make sure that all interferences that may affect the force are removed. Pay attention to the force application direction.  Tip If the ball screw will interfere with the handheld dynamometer, adjust the ball screw manually.	Used belt: 45-51N New belt:65-71N  <p>xx1900000095</p>

Continues on next page

5 Repair

5.6.10 Replacing the outer arm

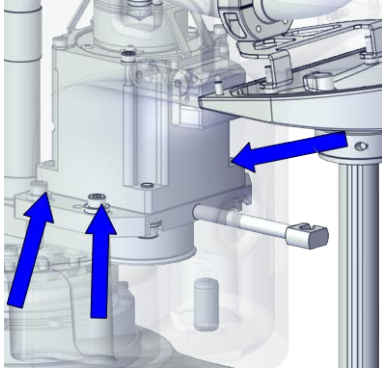
Continued

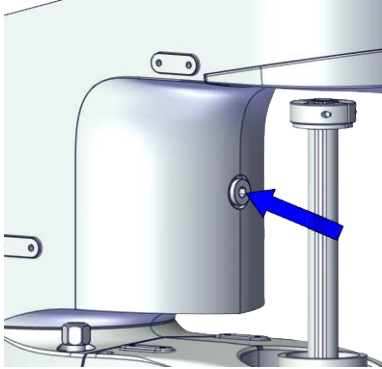
	Action	Note
8	Fasten the screws to the recommended tightening torque.	<p>Tightening torque: 3 Nm \pm10%</p>  <p>xx1800002880</p>
9	Use a sonic tension meter to measure the timing belt tension.	<p>Used belt: 193-236Hz New belt: 229-293Hz</p>
10	If the timing belt tension does not meet the requirement, loosen the motor screws and readjust.	
11	Remove the axis-1&2 belt tension adjustment tool.	
12	<p>Refit the plug.</p>  <p>Tip</p> <p>Just tighten it.</p>	<p>Tightening torque: 2 Nm \pm10%</p>  <p>xx1800002878</p>



Inserting the internal harness through the axis -2 gear box position

	Action	Note
1	<p>For robots with protection type Clean Room: Clean the joints that have been opened and wipe the parts free from particles with spirit on a lint free. See Cut the paint or surface on the robot before replacing parts on page 118</p>  <p>Note</p> <p>After all repair work, wipe the Clean Room robot free from particles with spirit on a lint free cloth.</p>	

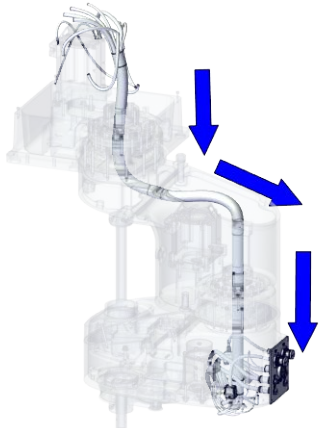
Continues on next page

	Action	Note
2	<p>Insert the internal harness into the outer arm through the centre of the axis-2 gearbox.</p> <p> Tip Wrap the connectors with the masking tape.</p>	 <p>xx1800003412</p>
3	Secure the R2.MP3 and R2.MP4 with cable straps.	

Refitting the cable bracket

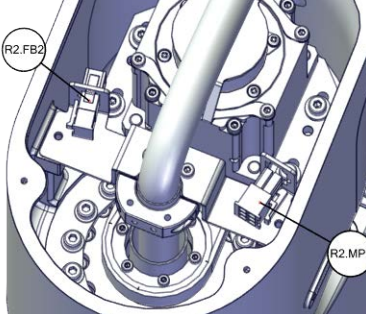

	Action	Note
1	<p>For robots with protection type Clean Room: Clean the joints that have been opened and wipe the parts free from particles with spirit on a lint free. See Cut the paint or surface on the robot before replacing parts on page 118</p> <p> Note After all repair work, wipe the Clean Room robot free from particles with spirit on a lint free cloth.</p>	
2	<p>Reconnect the connectors.</p> <ul style="list-style-type: none"> • R2.MP2 • R2.FB2 <p> Tip Take photos of the connector and cable position before disconnecting them, to have as a reference when reconnecting.</p> <p> Tip See the number markings on the connectors for help to find the corresponding connector.</p>	 <p>xx1800002875</p>
3	Lay the internal harness in a natural state without distortion.	

Continues on next page

5 Repair

5.6.10 Replacing the outer arm

Continued

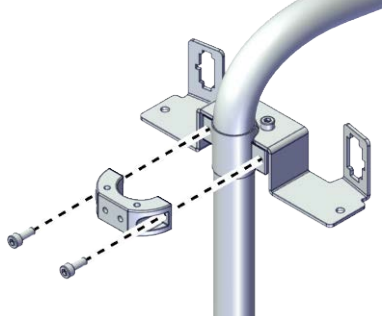
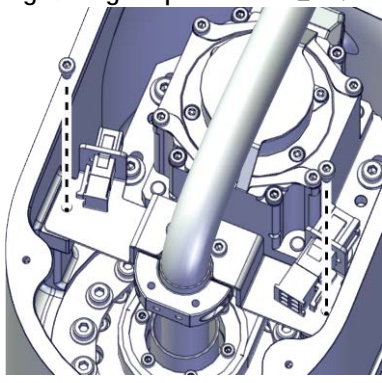

	Action	Note
4	<p>Refit the cable ferrule on the cable at the marked position and secure with screws.</p> <p> Tip</p> <p>The position with wrapped tape is the marked position for the cable ferrule.</p> <p> Tip</p> <p>Align all the cable ferrules so that the cable is in a natural bending position to avoid twisting.</p>	<p>Screws: Hex socket head cap screw M3x8 12.9 Lafre 2C2B/FC6.9 (2 pcs)</p> <p>Tightening torque: 1.5 Nm \pm10%</p>  <p>xx1800002876</p>
5	<p>Refit the bracket and secure with the screws.</p>	<p>Screws: Hex socket head cap screw M3x5 12.9 Lafre 2C2B/FC6.9 (2 pcs)</p> <p>Tightening torque: 1.5 Nm \pm10%</p>  <p>xx1800002874</p>

Refitting the process hub

	Action	Note
1	<p>For robots with protection type Clean Room: Clean the joints that have been opened and wipe the parts free from particles with spirit on a lint free. See Cut the paint or surface on the robot before replacing parts on page 118</p> <p> Note</p> <p>After all repair work, wipe the Clean Room robot free from particles with spirit on a lint free cloth.</p>	

Continues on next page

5.6.10 Replacing the outer arm
Continued

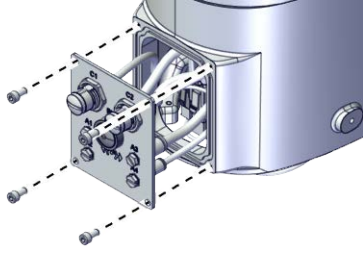
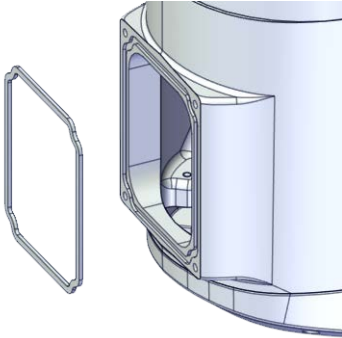
	Action	Note
2	<p>Refit the process hub to the outer arm and secure it with the screws.</p> <p> Note</p> <p>For robots with protection class IP54 (option 3350-540) For robots with protection type Clean Room (option 3351-1) Check the gasket for the process hub on the outer arm.</p> <p> Tip</p> <p>Replace the gasket if needed.</p> <p> CAUTION</p> <p>Be aware of the cabling that is attached to the cover! The cover can not be removed completely until the connectors are disconnected, as shown in following steps.</p>	<p>Screws: Hex socket head cap screw M4x8 12.9 Lafre 2C2B/FC6.9 (4 pcs) Tightening torque: 4 Nm ±10%</p>  <p>xx1800002848</p> <p>For robots with protection class IP54 (option 3350-540) For robots with protection type Clean Room (option 3351-1)</p>  <p>xx1900001638</p>

Refitting the cable ferrule and protected bracket





	Action	Note
1	<p>For robots with protection type Clean Room: Clean the joints that have been opened and wipe the parts free from particles with spirit on a lint free. See Cut the paint or surface on the robot before replacing parts on page 118</p> <p> Note</p> <p>After all repair work, wipe the Clean Room robot free from particles with spirit on a lint free cloth.</p>	
2	<p>Lay the internal harness in a natural state without distortion.</p>	

Continues on next page

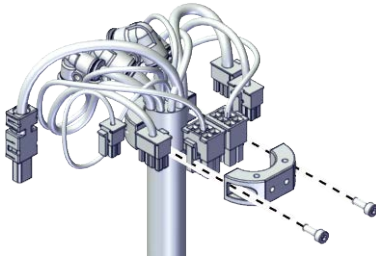

5 Repair

5.6.10 Replacing the outer arm

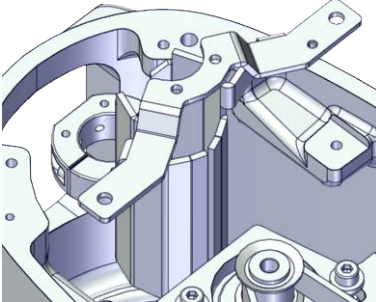
Continued

	Action	Note
3	<p>Refit the cable ferrule and secure it with the screws.</p> <p> Tip</p> <p>The air hoses should face the process hub side.</p> <p> Tip</p> <p>The position with wrapped tape is the marked position for the cable ferrule.</p> <p> Tip</p> <p>Align all the cable ferrules so that the cable is in a natural bending position to avoid twisting.</p>	<p>Screws: Hex socket head cap screw M3x8 12.9 Lafre 2C2B/FC6.9 (2 pcs)</p> <p>Tightening torque: 1.5 Nm \pm10%</p>  <p>xx1800002849</p>
4	<p>Refit the protected bracket.</p> <p> Tip</p> <p>Do not secure it with the screws before the cable ferrule installed well.</p> <p> Note</p> <p>The harness are not visible due to the cleanness requirements of the illustration. They are still existing inside the cable ferrule in the actual situation.</p>	<p>Screws: Hex socket head cap screw M4x8 12.9 Lafre 2C2B/FC6.9 (2 pcs)</p> <p>Tightening torque: 4 Nm \pm10%</p>  <p>xx1900000078</p>

Continues on next page

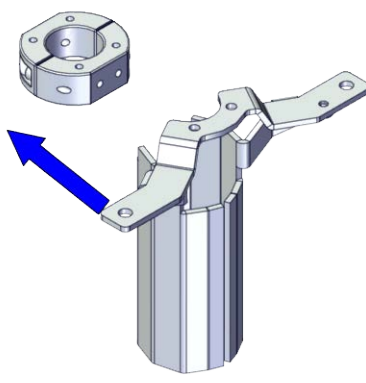
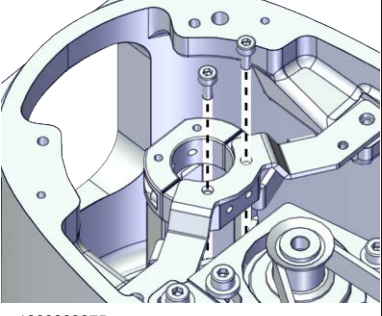
	Action	Note
5	<p>Secure the cable ferrule to the protected bracket.</p> <p> Tip</p> <p>Align all the cable ferrules so that the cable is in a natural bending position to avoid twisting.</p> <p> Note</p> <p>The harness are not visible due to the cleanness requirements of the illustration. They are still existing inside the cable ferrule in the actual situation.</p>	<p>Screws: Hex socket head cap screw M3x5 12.9 Lafre 2C2B/FC6.9 (2 pcs)</p> <p>Tightening torque: 1.5 Nm ±10%</p>  <p>xx1900000076</p>  <p>xx1900000075</p>

Reconnecting the connector for PB





	Action	Note
1	<p>For robots with protection type Clean Room: Clean the joints that have been opened and wipe the parts free from particles with spirit on a lint free. See Cut the paint or surface on the robot before replacing parts on page 118</p> <p> Note</p> <p>After all repair work, wipe the Clean Room robot free from particles with spirit on a lint free cloth.</p>	

Continues on next page

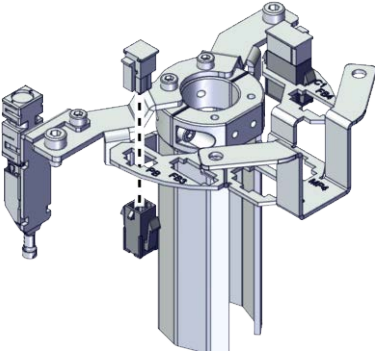

5 Repair

5.6.10 Replacing the outer arm

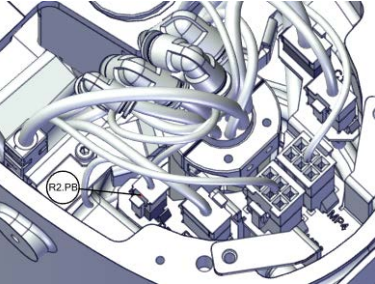





Continued

	Action	Note
2	<p>Insert the female head of the PB connector to the bracket accordingly.</p> <p> Tip</p> <p>The mistake proofing measure has been applied to the connectors, the connectors may be damaged if excessive force is used.</p> <p> Note</p> <p>The harness are not visible due to the cleanliness requirements of the illustration. They are still existing inside the cable ferrule in the actual situation.</p>	 <p>xx1900000069</p>
3	<p>Reconnect the connector.</p> <ul style="list-style-type: none"> • R2.PB <p> Tip</p> <p>See the number markings on the connectors for help to find the corresponding connector.</p>	 <p>xx1900000068</p>

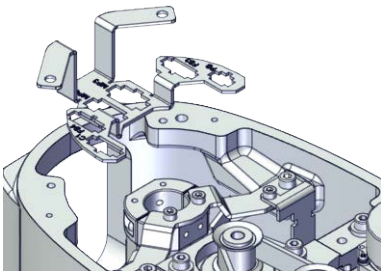
Reconnecting the air hoses, CP/CS cabling and Ethernet cabling (if equipped)

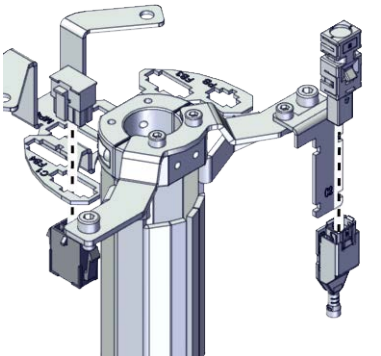
	Action	Note
1	<p>For robots with protection type Clean Room: Clean the joints that have been opened and wipe the parts free from particles with spirit on a lint free. See Cut the paint or surface on the robot before replacing parts on page 118</p> <p> Note</p> <p>After all repair work, wipe the Clean Room robot free from particles with spirit on a lint free cloth.</p>	
2	<p>Route the air hoses on the process hub behind the protected bracket.</p> <p> CAUTION</p> <p>Correct cable routing is highly important. If the cables are routed and secured incorrectly the cables can be damaged.</p>	

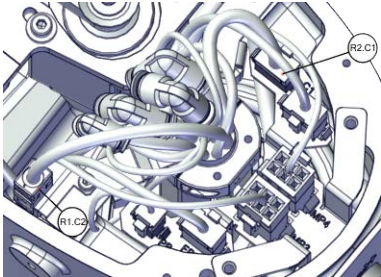
Continues on next page





	Action	Note
3	<p>Refit the bracket to the outer arm without screws.</p> <p> Note</p> <p>The harness are not visible due to the cleanness requirements of the illustration. They are still existing inside the cable ferrule in the actual situation.</p>	 <p>xx1900000073</p>
4	<p>Insert the female head of the C1 cabling connector to the bracket accordingly.</p> <p> Tip</p> <p>The mistake proofing measure has been applied to the connectors, the connectors may be damaged if excessive force is used.</p>	 <p>xx1900000071</p>
5	<p>For robots with C1 cabling</p> <p>Reconnect the connector.</p> <ul style="list-style-type: none"> • R2.C1 <p> Tip</p> <p>See the number markings on the air hoses for help to find the corresponding air hoses. The air hoses with the same number connect to the same L-shaped connector.</p> <p> Note</p> <p>The harness are not visible due to the cleanness requirements of the illustration. They are still existing inside the cable ferrule in the actual situation.</p>	 <p>xx1900000070</p>
6	<p>For robots with C2 cabling</p> <p>Reconnect the connector.</p> <ul style="list-style-type: none"> • R1.C2 <p> Tip</p> <p>See the number markings on the air hoses for help to find the corresponding air hoses. The air hoses with the same number connect to the same L-shaped connector.</p>	
7	<p>Secure the C2 cabling to the C2 bracket with the cable straps.</p>	

Continues on next page

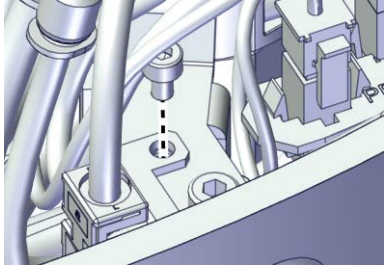

5 Repair

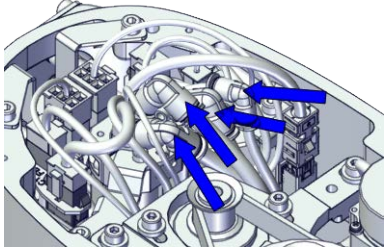
5.6.10 Replacing the outer arm



Continued

	Action	Note
8	Secure the C2 bracket to the bracket with screw.	<p>Screws: Hex socket head cap screw M3x5 12.9 Lafre 2C2B/FC6.9 (1 pcs)</p> <p>Tightening torque: 4 Nm \pm10%</p>  <p>xx1900000098</p>
9	<p>Reconnect the air hoses in a cross pattern with the L-shaped connectors.</p>  <p>Tip</p> <p>See the number markings on the air hoses for help to find the corresponding air hoses. The air hoses with the same number connect to the same Y-shaped connector.</p>	 <p>xx1800002837</p>
10	<p>Route and secure the cabling with cable straps if needed.</p>  <p>CAUTION</p> <p>Correct cable routing is highly important. If the cables are routed and secured incorrectly the cables can be damaged.</p>	

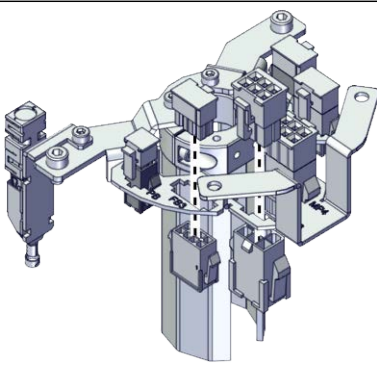

Reconnecting the connectors for axis-3 motor

	Action	Note
1	<p>For robots with protection type Clean Room: Clean the joints that have been opened and wipe the parts free from particles with spirit on a lint free. See Cut the paint or surface on the robot before replacing parts on page 118</p>  <p>Note</p> <p>After all repair work, wipe the Clean Room robot free from particles with spirit on a lint free cloth.</p>	
2	<p>Route the cabling on the axis-3 motor behind the protected bracket to the bracket.</p>  <p>CAUTION</p> <p>Correct cable routing is highly important. If the cables are routed and secured incorrectly the cables can be damaged.</p>	

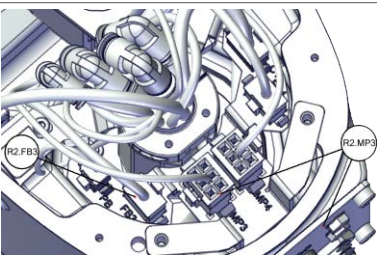
Continues on next page

	Action	Note
3	<p>Insert the female head of the connectors to the bracket accordingly.</p> <p> Tip</p> <p>The mistake proofing measure has been applied to the connectors, the connectors may be damaged if excessive force is used.</p>	 <p>xx1900000064</p>
4	<p>Reconnect the connectors.</p> <ul style="list-style-type: none"> • R2.MP3 • R2.FB3 <p> Tip</p> <p>See the number markings on the connectors for help to find the corresponding connector.</p>	 <p>xx1900000063</p>



Reconnecting the connectors for axis-4 motor

	Action	Note
1	<p>For robots with protection type Clean Room: Clean the joints that have been opened and wipe the parts free from particles with spirit on a lint free. See Cut the paint or surface on the robot before replacing parts on page 118</p> <p> Note</p> <p>After all repair work, wipe the Clean Room robot free from particles with spirit on a lint free cloth.</p>	
2	<p>Route the cabling on the axis-4 motor behind the protected bracket to the bracket.</p> <p> CAUTION</p> <p>Correct cable routing is highly important. If the cables are routed and secured incorrectly the cables can be damaged.</p>	

5 Repair

5.6.10 Replacing the outer arm

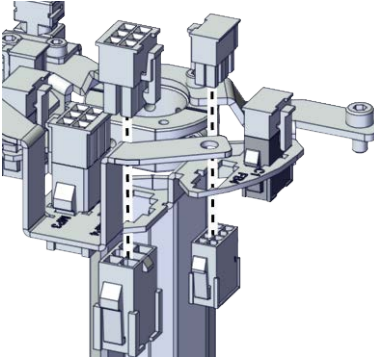
Continued

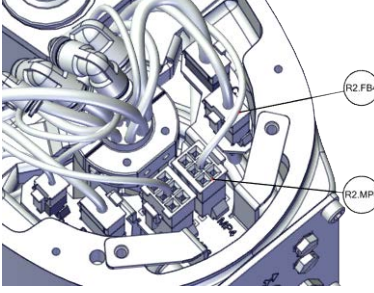

	Action	Note
	<p>Insert the female head of the connectors to the bracket accordingly.</p> <p> Tip</p> <p>The mistake proofing measure has been applied to the connectors, the connectors may be damaged if excessive force is used.</p>	 <p>xx1900000066</p>
3	<p>Reconnect the connectors.</p> <ul style="list-style-type: none"> • R2.MP4 • R2.FB4 <p> Tip</p> <p>See the number markings on the connectors for help to find the corresponding connector.</p>	 <p>xx1900000065</p>

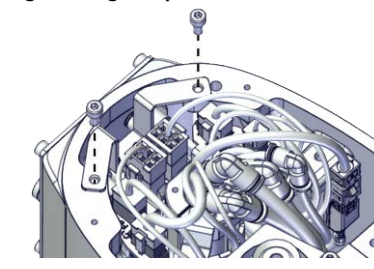
Refitting the bracket for the process hub

	Action	Note
1	<p>For robots with protection type Clean Room: Clean the joints that have been opened and wipe the parts free from particles with spirit on a lint free. See Cut the paint or surface on the robot before replacing parts on page 118</p> <p> Note</p> <p>After all repair work, wipe the Clean Room robot free from particles with spirit on a lint free cloth.</p>	
2	<p>Secure the bracket with screws.</p>	<p>Screws: Hex socket head cap screw M4x8 12.9 Lafre 2C2B/FC6.9 (2 pcs) Tightening torque: 4 Nm ±10%</p>  <p>xx1800002839</p>

Continues on next page

Refitting the casting cover of the inner arm

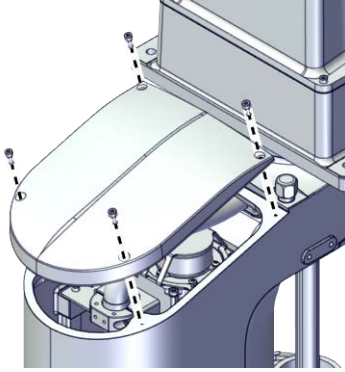
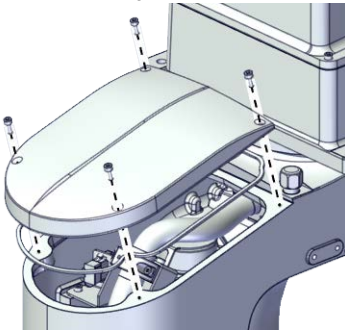
	Action	Note
1	<p>For robots with protection type Clean Room: Clean the joints that have been opened and wipe the parts free from particles with spirit on a lint free. See Cut the paint or surface on the robot before replacing parts on page 118</p> <p> Note</p> <p>After all repair work, wipe the Clean Room robot free from particles with spirit on a lint free cloth.</p>	
2	<p>Refit the casting cover.</p> <p> Note</p> <p>For robots with protection class IP54 (option 3350-540)</p> <p>For robots with protection type Clean Room (option 3351-1)</p> <p>Check the gasket for the casting cover before refitting the base cover.</p> <p> Tip</p> <p>Replace the gasket if needed.</p>	<p>Screw: Hex socket head cap screw M3x8 12.9 Lafre 2C2B/FC6.9 (4 pcs)</p> <p>Tightening torque: 1.2 Nm ±10%</p> <p>For robots with protection class IP30 (option 3350-300)</p>  <p>xx1800002873</p>
3	<p>Refit the screws.</p>	<p>For robots with protection class IP54 (option 3350-540)</p> <p>For robots with protection type Clean Room (option 3351-1)</p>  <p>xx1900001637</p>





Continues on next page

5 Repair

5.6.10 Replacing the outer arm

Continued

Refitting the casting cover of the outer arm

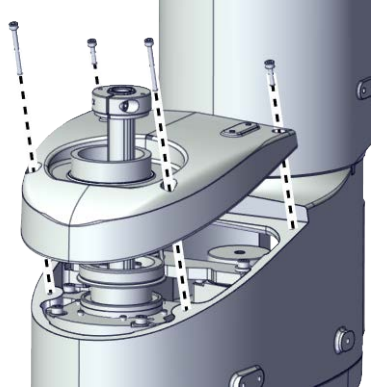
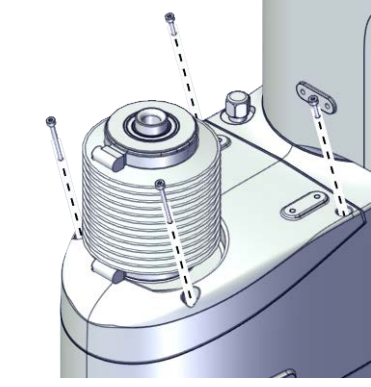
	Action	Note
1	<p>For robots with protection type Clean Room: Clean the joints that have been opened and wipe the parts free from particles with spirit on a lint free. See Cut the paint or surface on the robot before replacing parts on page 118</p> <p> Note</p> <p>After all repair work, wipe the Clean Room robot free from particles with spirit on a lint free cloth.</p>	
2	<p>Refit the cover.</p> <p> Note</p> <p>For robots with protection class IP54 (option 3350-540) For robots with protection type Clean Room (option 3351-1)</p> <p>Refit the cover with bellow and housing. Check the gasket on the casting cover.</p> <p> CAUTION</p> <p>There is a gasket in the cover. Be careful when refitting the cover with bellow and housing.</p> <p> Tip</p> <p>Replace the gasket if needed.</p>	<p>Long screw: Hex socket head cap screw M3x30 12.9 Lafre 2C2B/FC6.9 (2 pcs) Tightening torque: 1.2 Nm ±10%</p> <p>Short screw: Hex socket head cap screw M3x12 12.9 Lafre 2C2B/FC6.9 (2 pcs) Tightening torque: 1.2 Nm ±10%</p> <p>For robots with protection class IP30 (option 3350-300)</p>  <p>xx1800002883</p>
3	<p>Refit the screws.</p>	<p>For robots with protection class IP54 (option 3350-540) For robots with protection type Clean Room (option 3351-1)</p>  <p>xx1900001628</p>

Continues on next page

Refitting the upper cover

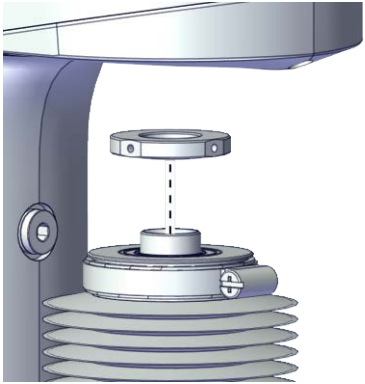
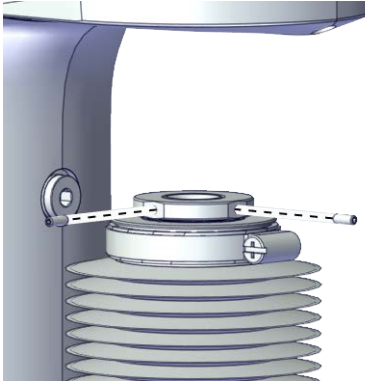
	Action	Note
1	<p>For robots with protection type Clean Room: Clean the joints that have been opened and wipe the parts free from particles with spirit on a lint free. See Cut the paint or surface on the robot before replacing parts on page 118</p> <p> Note</p> <p>After all repair work, wipe the Clean Room robot free from particles with spirit on a lint free cloth.</p>	
2	<p>For robots with protection class IP54 (option 3350-540) For robots with protection type Clean Room (option 3351-1) Refit the upper cover to the ball screw.</p>	 <p>xx1900001548</p>
3	<p>For robots with protection class IP54 (option 3350-540) For robots with protection type Clean Room (option 3351-1) Refit the locking screws.</p>	<p>Screws: Hexagon socket set screws with flat point, ISO 4026 stainless steel M3x8 (2 pcs) Tightening torque: 0.6 Nm ±10%</p>  <p>xx1900001547</p>

Continues on next page

5 Repair



5.6.10 Replacing the outer arm

Continued

Refitting the cover of the outer arm

	Action	Note
1	<p>For robots with protection type Clean Room: Clean the joints that have been opened and wipe the parts free from particles with spirit on a lint free. See Cut the paint or surface on the robot before replacing parts on page 118</p> <p> Note</p> <p>After all repair work, wipe the Clean Room robot free from particles with spirit on a lint free cloth.</p>	

Continues on next page

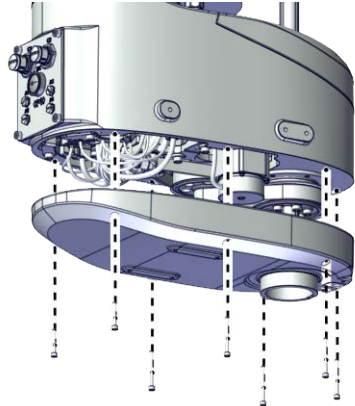
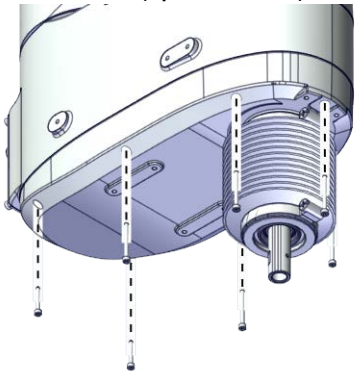
	Action	Note
2	<p>Refit the cover.</p> <p> Note</p> <p>For robots with protection class IP54 (option 3350-540)</p> <p>For robots with protection type Clean Room (option 3351-1)</p> <p>Refit the cover with bellow and housing.</p> <p>Check the gasket on the outer arm cover.</p> <p> Tip</p> <p>Replace the gasket if needed.</p>	<p>For IRB 910INV-3/0.35:</p> <p>Screw: Hex socket head cap screw M3x20 12.9 Lafre 2C2B/FC6.9 (2 pcs)</p> <p>Hex socket head cap screw M3x30 12.9 Lafre 2C2B/FC6.9 (5 pcs)</p> <p>Tightening torque: 1.2 Nm ±10%</p> <p>For IRB 910INV-6/0.55:</p> <p>Screw: Hex socket head cap screw M3x20 12.9 Lafre 2C2B/FC6.9 (2 pcs)</p> <p>Hex socket head cap screw M3x30 12.9 Lafre 2C2B/FC6.9 (7 pcs)</p> <p>Tightening torque: 1.2 Nm ±10%</p> <p>For robots with protection class IP30 (option 3350-300)</p>
3	<p>Refit the screws.</p>	 <p>xx1800002836</p> <p>For robots with protection class IP54 (option 3350-540)</p> <p>For robots with protection type Clean Room (option 3351-1)</p>  <p>xx1900001631</p>

Continues on next page

5 Repair

5.6.10 Replacing the outer arm

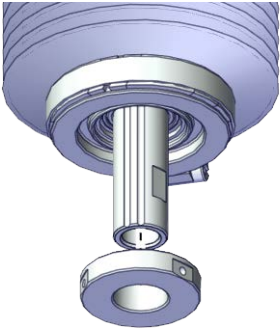
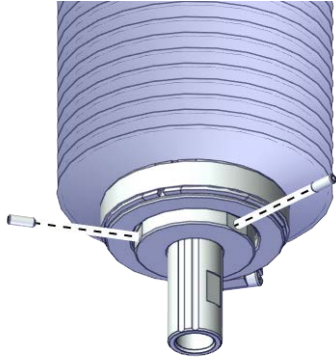

Continued

Refitting the lower cover

	Action	Note
1	<p>For robots with protection type Clean Room: Clean the joints that have been opened and wipe the parts free from particles with spirit on a lint free. See Cut the paint or surface on the robot before replacing parts on page 118</p> <p> Note</p> <p>After all repair work, wipe the Clean Room robot free from particles with spirit on a lint free cloth.</p>	
2	<p>For robots with protection class IP54 (option 3350-540)</p> <p>For robots with protection type Clean Room (option 3351-1)</p> <p>Refit the lower cover to the ball screw.</p>	 <p>xx1900001607</p>
3	<p>For robots with protection class IP54 (option 3350-540)</p> <p>For robots with protection type Clean Room (option 3351-1)</p> <p>Refit the locking screws.</p>	<p>Screws: Hexagon socket set screws with flat point, ISO 4026 stainless steel M3x8 (2 pcs)</p> <p>Tightening torque: 0.6 Nm ±10%</p>  <p>xx1900001606</p>

Continues on next page

Concluding procedure

	Action	Note
1	<p>For robots with protection type Clean Room: Seal and paint the joints that have been opened. See Cut the paint or surface on the robot before replacing parts on page 118</p> <p> Note</p> <p>After all repair work, wipe the Clean Room robot free from particles with spirit on a lint free cloth.</p>	
2	Recalibrate the robot.	Calibration is detailed in section Calibration on page 771 .
3	<p> DANGER</p> <p>Make sure all safety requirements are met when performing the first test run. See Test run after installation, maintenance, or repair on page 56.</p>	

5 Repair

5.7.1 Replacing the axis-1 motor sub-assembly

5.7 Motors

5.7.1 Replacing the axis-1 motor sub-assembly

Location of the axis-1 motor sub-assembly

The axis-1 motor sub-assembly is located as shown in the figure.

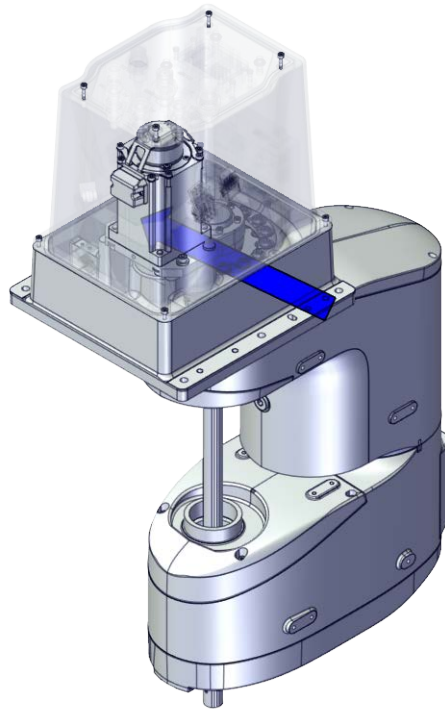

xx1800002866

Required spare parts



Note

The spare part numbers that are listed in the table can be out of date. See the latest spare parts of the IRB 910INV via myABB Business Portal, www.abb.com/myABB.

Spare part	Article number	Note
Axis-1 motor sub-assembly	3HAC083595-001	
Timing belt	3HAC061864-001	

Required tools and equipment

Equipment	Article number	Note
Standard toolkit	-	Content is defined in section Standard toolkit on page 840 .

Continues on next page

5.7.1 Replacing the axis-1 motor sub-assembly

Continued

Equipment	Article number	Note
Calibration tool box, Axis Calibration	3HAC074119-001	Delivered as a set of calibration tools. Required if Axis Calibration is the valid calibration method for the robot. ⁱ
Belt tension adjustment tool set, axis 1&2	-	Included in the special toolkit 3HAC073070-001. Used to adjust the tension of axis-1&2 timing belts. Special tool for L2
Sonic tension meter	-	Used for measuring the timing belt tension.
Handheld dynamometer	-	Used for measuring the timing belt tension.

ⁱ The robot is calibrated by either manual calibration or Axis Calibration at ABB factory before delivery. Always use the same calibration method as used at the factory.
Information about valid calibration method is found on the calibration label or in the calibration menu on the FlexPendant.
If no data is found related to standard calibration, manual calibration is used as default.

Required consumables

Consumable	Article number	Note
Cable straps	-	
Grease	3HAC029132-001	FM 222 Used to lubricate the cable harness.

Deciding calibration routine

Decide which calibration routine to be used, based on the information in the table. Depending on which routine is chosen, action might be required prior to beginning the repair work of the robot, see the table.

	Action	Note
1	Decide which calibration routine to use for calibrating the robot. <ul style="list-style-type: none"> Reference calibration. External cable packages (DressPack) and tools can stay fitted on the robot. Fine calibration. All external cable packages (DressPack) and tools must be removed from the robot. 	
	<p>If the robot is to be calibrated with reference calibration:</p> <p>Find previous reference values for the axis or create new reference values. These values are to be used after the repair procedure is completed, for calibration of the robot.</p> <p>If no previous reference values exist, and no new reference values can be created, then reference calibration is not possible.</p>	<p>Follow the instructions given in the reference calibration routine on the FlexPendant to create reference values.</p> <p>Creating new values requires possibility to move the robot.</p> <p>Read more about reference calibration for Axis Calibration in Reference calibration routine on page 798.</p>

Continues on next page

5 Repair

5.7.1 Replacing the axis-1 motor sub-assembly



Continued

Action	Note
<p>If the robot is to be calibrated with fine calibration: Remove all external cable packages (DressPack) and tools from the robot.</p>	

Removing the axis-1 motor sub-assembly

Use these procedures to remove the axis-1 motor sub-assembly.

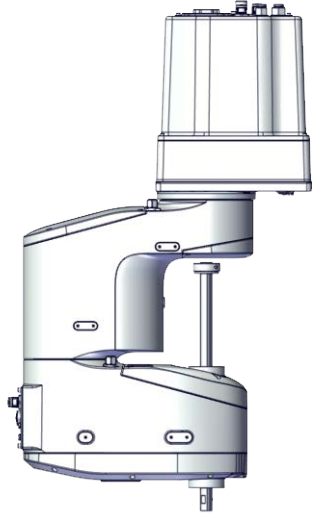

Preparations before removing the axis-1 motor sub-assembly

Action	Note
1	Decide which calibration routine to use, and take actions accordingly prior to beginning the repair procedure.
2	<p>If there is no enough space for the maintenance work, remove the robot from the wall and place it on the maintenance bracket.</p> <p> CAUTION</p> <p>Do not lay down the robot during the transportation, always keep it straight. If the robot lay down in any situation, the grease may come out from gearbox.</p>
3	<p>Jog all axes to zero position.</p> <div style="text-align: right;">  <p>xx1800002825</p> </div>
4	<p> DANGER</p> <p>Turn off all:</p> <ul style="list-style-type: none"> • electric power supply • hydraulic pressure supply • air pressure supply <p>to the robot, before entering the safeguarded space.</p>

Continues on next page

	Action	Note
5	 CAUTION For robots with protection type Clean Room Always cut the paint with a knife and grind the paint edge when disassembling parts of the robot! See <i>Cut the paint or surface on the robot before replacing parts on page 118.</i>	

Removing the base cover

	Action	Note
1	 DANGER Make sure that all supplies for electrical power, hydraulic pressure, and air pressure are turned off.	
2	 CAUTION For robots with protection type Clean Room Always cut the paint with a knife and grind the paint edge when disassembling parts of the robot! See <i>Cut the paint or surface on the robot before replacing parts on page 118.</i>	

Continues on next page

5 Repair

5.7.1 Replacing the axis-1 motor sub-assembly

Continued

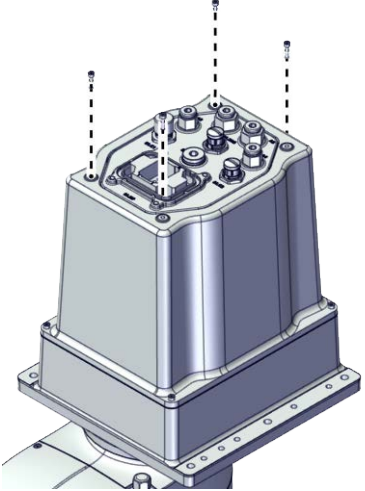
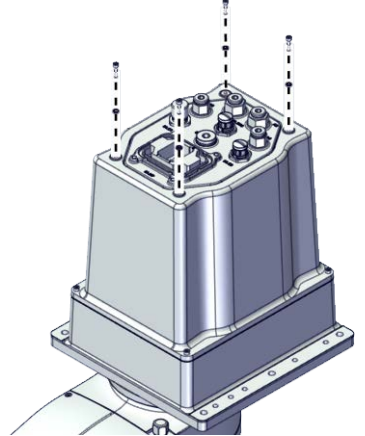

	Action	Note
3	<p>Remove the screws on the base cover to the base harness.</p> <p> Note</p> <p>For robots with protection class IP54 (option 3350-540)</p> <p>For robots with protection type Clean Room (option 3351-1)</p> <p>Remove the extra sealing washers on the base cover to the base harness.</p>	<p>For robots with protection class IP30 (option 3350-300)</p>  <p>xx1800002826</p> <p>For robots with protection class IP54 (option 3350-540)</p> <p>For robots with protection type Clean Room (option 3351-1)</p>  <p>xx1900001634</p>

Continues on next page

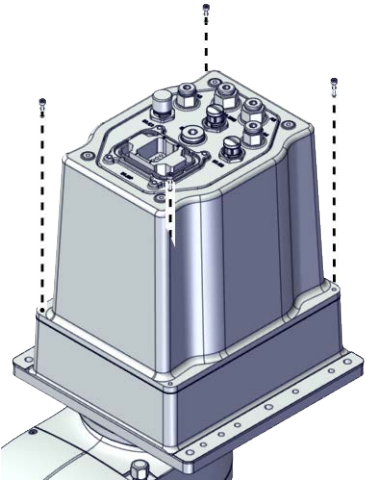
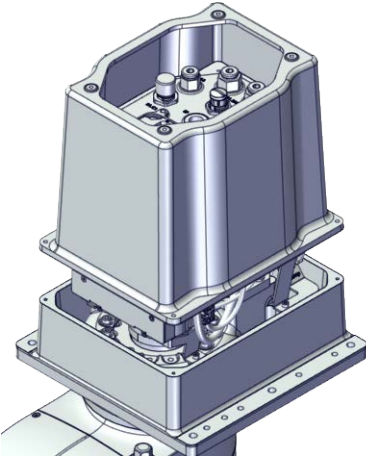
5.7.1 Replacing the axis-1 motor sub-assembly
Continued

	Action	Note
4	Remove the screws on the base cover to the base.	 <p>xx1800002827</p>
5	Take the base cover out.	 <p>xx1800002828</p>

Disconnecting the connectors on the base harness



	Action	Note
1	 <p>DANGER</p> <p>Make sure that all supplies for electrical power, hydraulic pressure, and air pressure are turned off.</p>	
2	 <p>CAUTION</p> <p>For robots with protection type Clean Room Always cut the paint with a knife and grind the paint edge when disassembling parts of the robot! See Cut the paint or surface on the robot before replacing parts on page 118.</p>	

Continues on next page

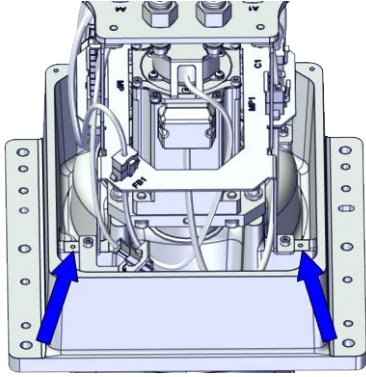

5 Repair

5.7.1 Replacing the axis-1 motor sub-assembly

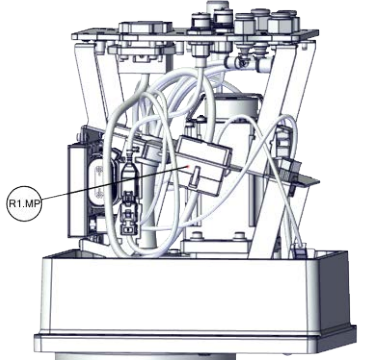
Continued





	Action	Note
3	Remove the three grounding cables from the bracket by unscrew the screws.	 xx1900000062
4	Disconnect the connector. <ul style="list-style-type: none"> R1.MP  Tip Take photos of the connector and cable position before disconnecting them, to have as a reference when reconnecting.	 xx1800002829

Disconnecting the air hoses, C1 cabling and C2 cabling (if equipped)

	Action	Note
1	 DANGER Make sure that all supplies for electrical power, hydraulic pressure, and air pressure are turned off.	
2	 CAUTION For robots with protection type Clean Room Always cut the paint with a knife and grind the paint edge when disassembling parts of the robot! See Cut the paint or surface on the robot before replacing parts on page 118.	

Continues on next page

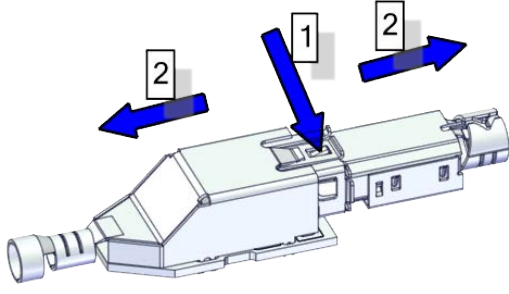
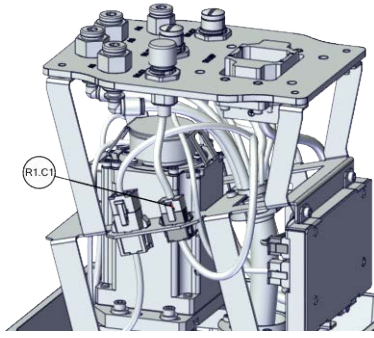
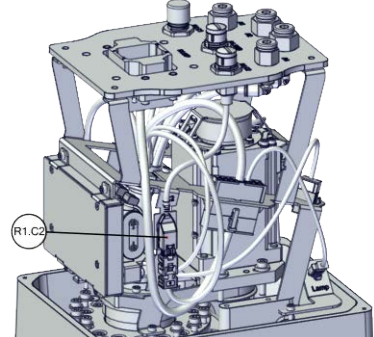
5.7.1 Replacing the axis-1 motor sub-assembly
Continued

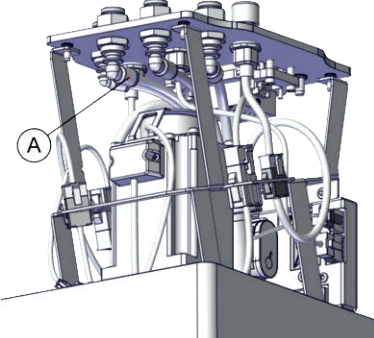
	Action	Note		
3	<p>Cut the cable straps and disconnect the connectors.</p> <ul style="list-style-type: none"> • R1.C1 • R1.C2 <p> Tip</p> <p>Take photos of the connector and cable position before disconnecting them, to have as a reference when reconnecting.</p> <p> Tip</p> <p>The connector clip has to be pressed (1) and pushed forward (2) to separate the R1.C2 (for C2 cabling).</p>  <p>xx1800002943</p>	 <p>xx1800002831</p>  <p>xx1800002832</p>		
4	<p>Disconnect the air hoses from the L-shaped connectors.</p> <p> Note</p> <p>Make sure that the air hoses are not bent or broken when you disconnect them.</p>	 <p>xx1800002830</p> <table border="1" data-bbox="1061 1612 1436 1657"> <tr> <td data-bbox="1061 1612 1117 1657">A</td> <td data-bbox="1117 1612 1436 1657">Air hoses</td> </tr> </table>	A	Air hoses
A	Air hoses			

Disconnecting the SMB cabling



	Action	Note
1	<p> DANGER</p> <p>Make sure that all supplies for electrical power, hydraulic pressure, and air pressure are turned off.</p>	

Continues on next page



5 Repair

5.7.1 Replacing the axis-1 motor sub-assembly

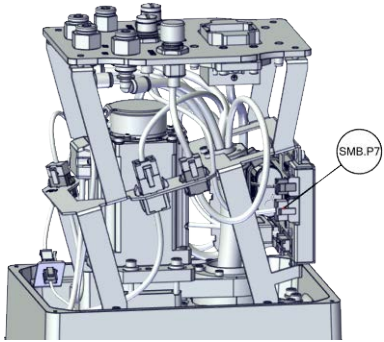
Continued

	Action	Note
2	 ELECTROSTATIC DISCHARGE (ESD) The unit is sensitive to ESD. Before handling the unit read the safety information in section The unit is sensitive to ESD on page 45 .	
3	 CAUTION For robots with protection type Clean Room Always cut the paint with a knife and grind the paint edge when disassembling parts of the robot! See Cut the paint or surface on the robot before replacing parts on page 118 .	
4	Disconnect the connectors. <ul style="list-style-type: none"> • SMB.P7 • SMB.J1 (Only when the internal harness)  Tip Take photos of the connector and cable position before disconnecting them, to have as a reference when reconnecting.	 <p>xx1800002833</p>

Removing the base harness



	Action	Note
1	 DANGER Make sure that all supplies for electrical power, hydraulic pressure, and air pressure are turned off.	
2	 CAUTION For robots with protection type Clean Room Always cut the paint with a knife and grind the paint edge when disassembling parts of the robot! See Cut the paint or surface on the robot before replacing parts on page 118 .	

Continues on next page

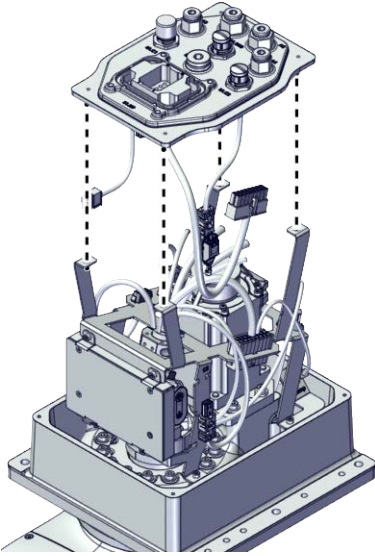
5.7.1 Replacing the axis-1 motor sub-assembly
Continued

	Action	Note
3	Remove the base harness from the bracket.	 <p>xx1800002834</p>

Removing the bracket

	Action	Note
1	 <p>DANGER</p> <p>Make sure that all supplies for electrical power, hydraulic pressure, and air pressure are turned off.</p>	
2	 <p>CAUTION</p> <p>For robots with protection type Clean Room Always cut the paint with a knife and grind the paint edge when disassembling parts of the robot! See <i>Cut the paint or surface on the robot before replacing parts on page 118.</i></p>	

Continues on next page

5 Repair

5.7.1 Replacing the axis-1 motor sub-assembly

Continued

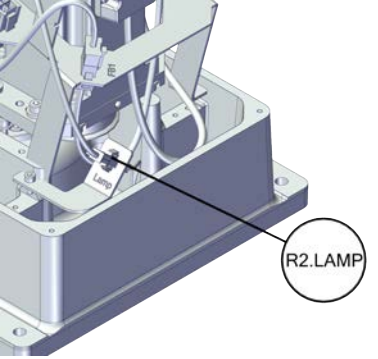
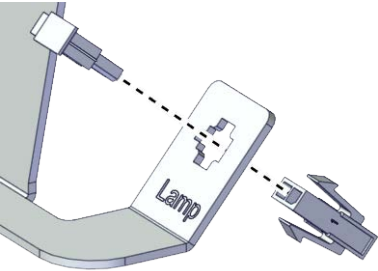
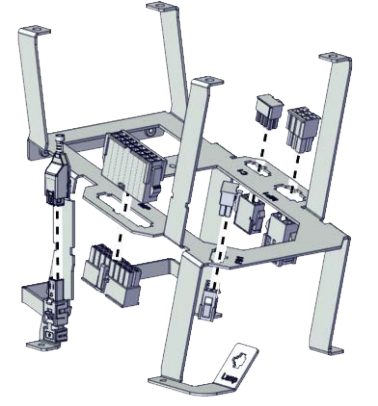
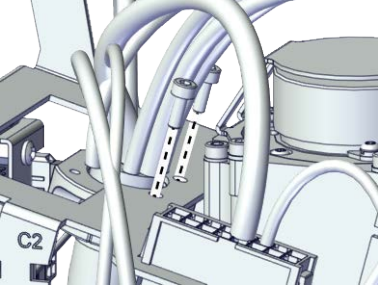

	Action	Note
3	Disconnect the lamp connector on the bracket.	 <p>xx1800002867</p>  <p>xx1900000079</p>
4	Snap loose and remove the female head of the connectors from the bracket.	 <p>xx1900000081</p>
5	Release the cable ferrule from the bracket.	 <p>xx1900000080</p>

Continues on next page

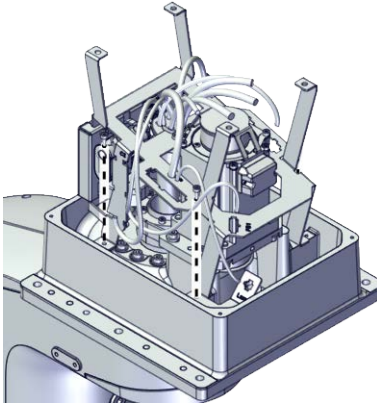
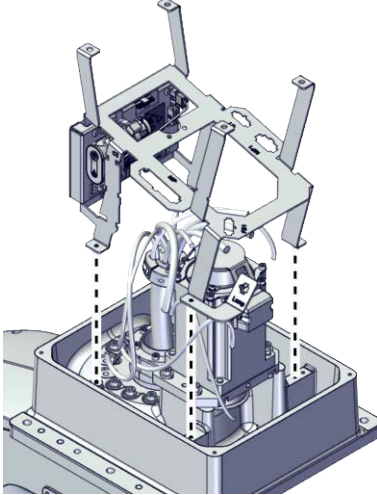
5.7.1 Replacing the axis-1 motor sub-assembly
Continued

	Action	Note
6	Remove the screws on the bracket.	 <p>xx1800002868</p>
7	Remove the bracket.	 <p>xx1800002869</p>

Removing the axis-1 motor sub-assembly

	Action	Note
1	 <p>DANGER</p> <p>Make sure that all supplies for electrical power, hydraulic pressure, and air pressure are turned off.</p>	
2	 <p>CAUTION</p> <p>For robots with protection type Clean Room Always cut the paint with a knife and grind the paint edge when disassembling parts of the robot! See Cut the paint or surface on the robot before replacing parts on page 118.</p>	

Continues on next page

5 Repair

5.7.1 Replacing the axis-1 motor sub-assembly

Continued

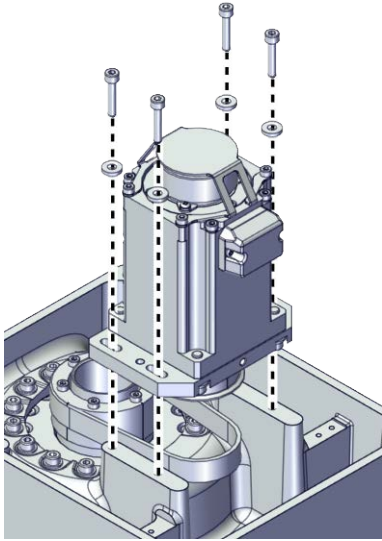
	Action	Note
3	Remove the screws and washers.	 <p>xx1800002870</p>
4	Remove the motor and the timing belt.	

Refitting the axis-1 motor sub-assembly



Use these procedures to refit the axis-1 motor sub-assembly.

Refitting the axis-1 motor sub-assembly

	Action	Note
1	<p>For robots with protection type Clean Room: Clean the joints that have been opened and wipe the parts free from particles with spirit on a lint free. See Cut the paint or surface on the robot before replacing parts on page 118</p> <p> Note</p> <p>After all repair work, wipe the Clean Room robot free from particles with spirit on a lint free cloth.</p>	

Continues on next page

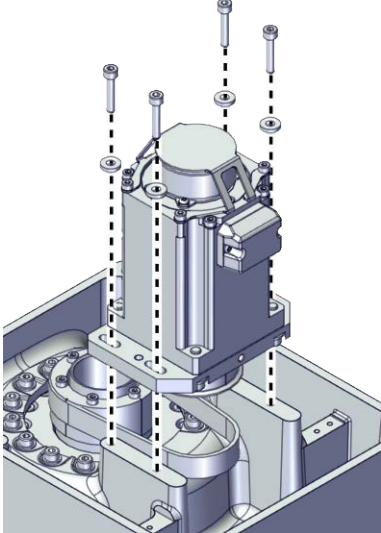
5.7.1 Replacing the axis-1 motor sub-assembly
Continued

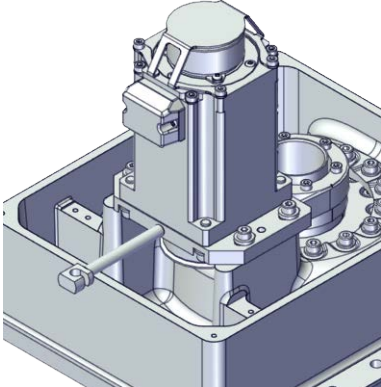
	Action	Note
2	Refit the timing belt to the pulley.	Screws: Hex socket head cap screw M4x20 12.9 Lafre 2C2B/FC6.9 (4 pcs) Washers: Washer 4.3x10x2 steel (4 pcs) Tightening torque: 3 Nm ±10%
3	Refit the motor.	
4	Refit the timing belt to the motor. Ensure that the belt runs correctly in the grooves.	
5	Refit the screws and washers without fully tightened.	 <p data-bbox="1059 1043 1166 1061">xx1800002870</p> <p data-bbox="1059 1081 1254 1140">Timing belt: 3HAC061864-001</p>
6	Install the axis1&2 belt tension adjustment tool to the motor.  Note Just tighten the tool.	Belt tension adjustment tool set, axis 1&2:-  <p data-bbox="1059 1619 1166 1637">xx1900000093</p>

Continues on next page

5 Repair

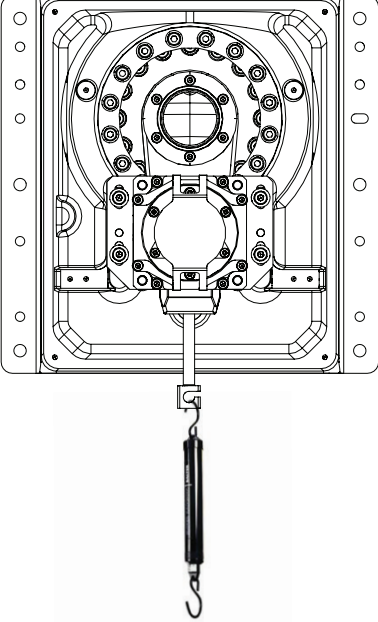
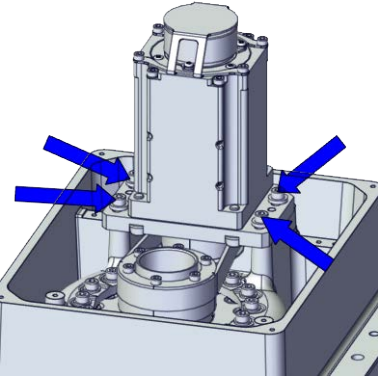

5.7.1 Replacing the axis-1 motor sub-assembly

Continued

	Action	Note
7	<p>Use a handheld dynamometer hooking to the special tool and pull the dynamometer to make the tension falling in the allowed force range.</p> <p> Note</p> <p>During the measurement, make sure that all interferences that may affect the force are removed. Pay attention to the force application direction.</p>	<p>Used belt: 70-80N New belt:100-110N</p>  <p>xx1900000094</p>
8	<p>Fasten the screws to the recommended tightening torque.</p>	<p>Tightening torque: 3 Nm \pm10%</p>  <p>xx1800002871</p>
9	<p>Use a sonic tension meter to measure the timing belt tension.</p>	<p>Used belt: 250-305Hz New belt:296-378Hz</p>
10	<p>If the timing belt tension does not meet the requirement, loosen the motor screws and readjust.</p>	

Continues on next page

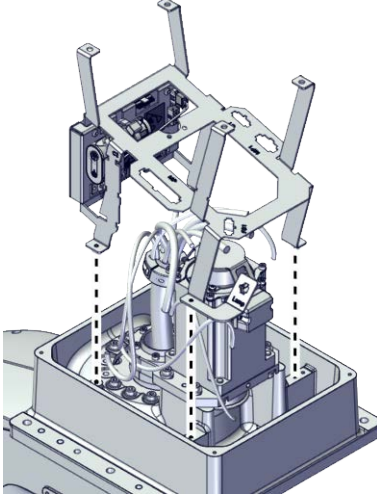
Refitting the bracket

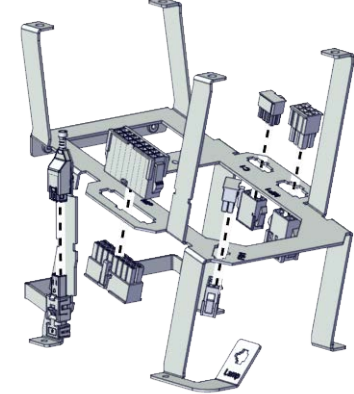
	Action	Note
1	<p>For robots with protection type Clean Room: Clean the joints that have been opened and wipe the parts free from particles with spirit on a lint free. See Cut the paint or surface on the robot before replacing parts on page 118</p> <p> Note</p> <p>After all repair work, wipe the Clean Room robot free from particles with spirit on a lint free cloth.</p>	
2	<p>Refit the bracket and secure with the screws.</p>	<p>Screws: Hex socket head cap screw M3x8 12.9 Lafre 2C2B/FC6.9 (4 pcs) Tightening torque: 1.5 Nm ±10%</p>  <p>xx1800002869</p>
3	<p>Insert the female head of the connectors to the bracket accordingly.</p> <p> Tip</p> <p>The mistake proofing measure has been applied to the connectors, the connectors may be damaged if excessive force is used.</p>	 <p>xx1900000081</p>

Continues on next page

5 Repair

5.7.1 Replacing the axis-1 motor sub-assembly

Continued

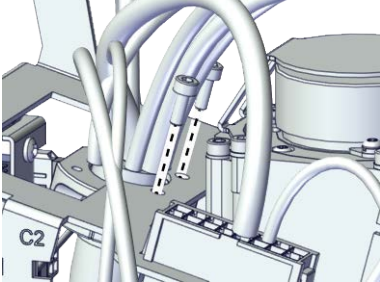
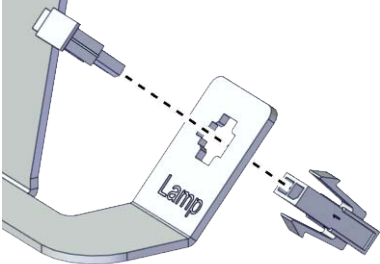
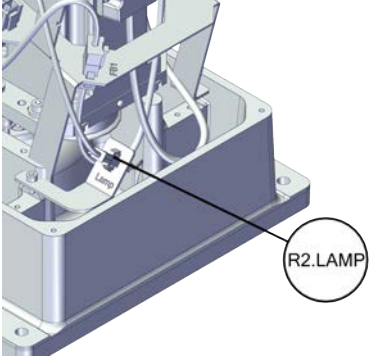
	Action	Note
4	Secure the cable ferrule to the bracket with the screws.	<p>Screws: Hex socket head cap screw M3x5 12.9 Lafre 2C2B/FC6.9 (2 pcs) Tightening torque: 1.5 Nm \pm10%</p>  <p>xx190000080</p>
5	Reconnect the lamp connector on the bracket.	 <p>xx190000079</p>  <p>xx1800002867</p>

Refitting the base harness



	Action	Note
1	<p>For robots with protection type Clean Room: Clean the joints that have been opened and wipe the parts free from particles with spirit on a lint free. See Cut the paint or surface on the robot before replacing parts on page 118</p> <p> Note</p> <p>After all repair work, wipe the Clean Room robot free from particles with spirit on a lint free cloth.</p>	

Continues on next page

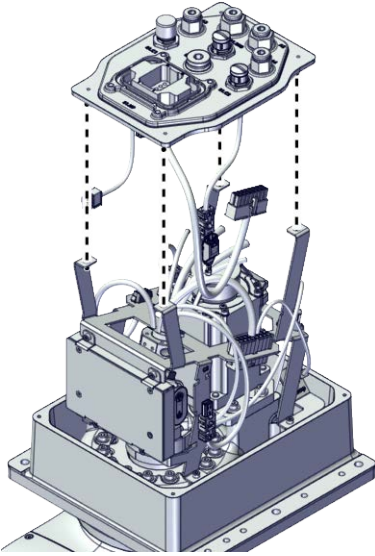
5.7.1 Replacing the axis-1 motor sub-assembly
Continued

	Action	Note
2	Refit the base harness to the bracket.	 <p>xx1800002834</p>

Reconnecting the SMB cabling

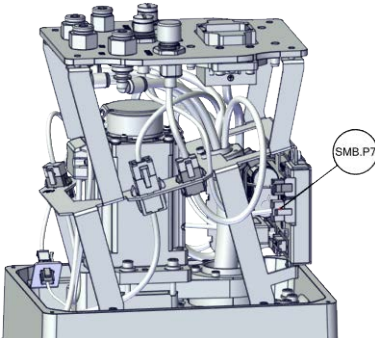
	Action	Note
1	 <p>ELECTROSTATIC DISCHARGE (ESD)</p> <p>The unit is sensitive to ESD. Before handling the unit read the safety information in section The unit is sensitive to ESD on page 45.</p>	
2	<p>For robots with protection type Clean Room: Clean the joints that have been opened and wipe the parts free from particles with spirit on a lint free. See Cut the paint or surface on the robot before replacing parts on page 118</p> <p> Note</p> <p>After all repair work, wipe the Clean Room robot free from particles with spirit on a lint free cloth.</p>	
3	<p>Reconnect the connectors.</p> <ul style="list-style-type: none"> • SMB.P7 • SMB.J1 <p> Tip</p> <p>See the number markings on the connectors for help to find the corresponding connector.</p>	 <p>xx1800002833</p>

Continues on next page



5 Repair

5.7.1 Replacing the axis-1 motor sub-assembly

Continued

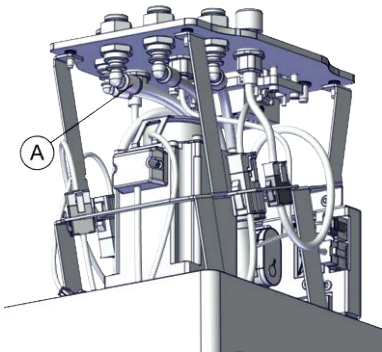

	Action	Note
4	<p>Route and secure the cabling with cable straps if needed.</p> <p> CAUTION</p> <p>Correct cable routing is highly important. If the cables are routed and secured incorrectly the cables can be damaged.</p>	

Reconnecting the air hoses, C1 cabling and C2 cabling (if equipped)

	Action	Note		
1	<p>For robots with protection type Clean Room: Clean the joints that have been opened and wipe the parts free from particles with spirit on a lint free. See Cut the paint or surface on the robot before replacing parts on page 118</p> <p> Note</p> <p>After all repair work, wipe the Clean Room robot free from particles with spirit on a lint free cloth.</p>			
2	<p>Reconnect the air hoses in a cross pattern to the L-shaped connectors on the base harness.</p> <p> Tip</p> <p>See the number markings on the air hoses for help to find the corresponding air hoses. The air hoses with the same number connect to the same L-shaped connector.</p> <p> Note</p> <p>Make sure that the air hoses are not bent or broken when you disconnect them.</p>	 <p>xx1800002830</p> <table border="1"> <tr> <td>A</td> <td>Air hoses</td> </tr> </table>	A	Air hoses
A	Air hoses			

Continues on next page

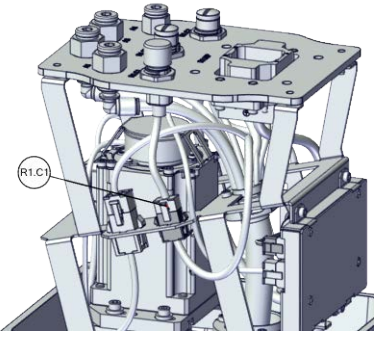
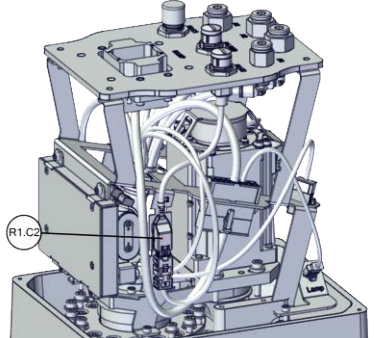
5.7.1 Replacing the axis-1 motor sub-assembly
Continued

	Action	Note
3	<p>Reconnect the connectors.</p> <ul style="list-style-type: none"> • R1.C1 • R1.C2 <p> Tip</p> <p>See the number markings on the connectors for help to find the corresponding connector.</p>	 <p>xx1800002831</p>  <p>xx1800002832</p>
4	<p>Route and secure the cabling with cable straps if needed.</p> <p> CAUTION</p> <p>Correct cable routing is highly important. If the cables are routed and secured incorrectly the cables can be damaged.</p>	

Reconnecting the connectors on the base harness



	Action	Note
1	<p>For robots with protection type Clean Room: Clean the joints that have been opened and wipe the parts free from particles with spirit on a lint free. See Cut the paint or surface on the robot before replacing parts on page 118</p> <p> Note</p> <p>After all repair work, wipe the Clean Room robot free from particles with spirit on a lint free cloth.</p>	

Continues on next page

5 Repair

5.7.1 Replacing the axis-1 motor sub-assembly

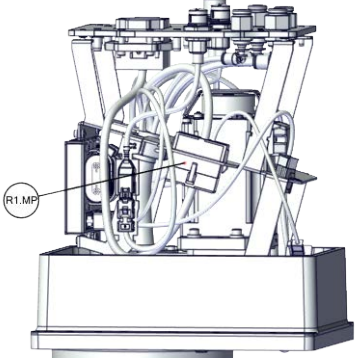
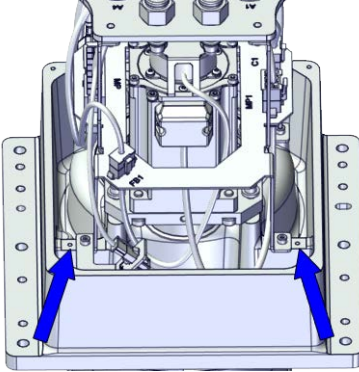
Continued



	Action	Note
2	<p>Reconnect the connector.</p> <ul style="list-style-type: none"> R1.MP <p> Tip</p> <p>See the number markings on the connectors for help to find the corresponding connector.</p>	 <p>xx1800002829</p>
3	<p>Secure the three grounding cables to the bracket with the screw.</p>	<p>Screws: Hex socket head cap screw M3x5 12.9 Lafre 2C2B/FC6.9 (2 pcs)</p> <p>Tightening torque: 1.5 Nm ±10%</p>  <p>xx1900000062</p>
4	<p>Route and secure the cabling with cable straps if needed.</p> <p> CAUTION</p> <p>Correct cable routing is highly important. If the cables are routed and secured incorrectly the cables can be damaged.</p>	

Refitting the base cover

	Action	Note
1	<p>For robots with protection type Clean Room:</p> <p>Clean the joints that have been opened and wipe the parts free from particles with spirit on a lint free. See Cut the paint or surface on the robot before replacing parts on page 118</p> <p> Note</p> <p>After all repair work, wipe the Clean Room robot free from particles with spirit on a lint free cloth.</p>	

Continues on next page

5.7.1 Replacing the axis-1 motor sub-assembly
Continued

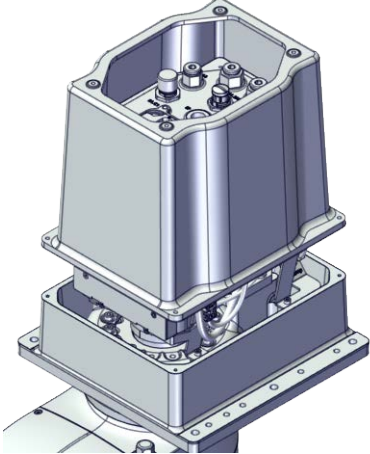
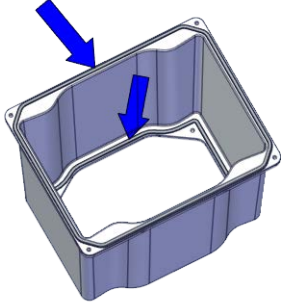
	Action	Note
2	Apply grease to the internal harness, cover all moving area of the harness.	
3	Apply grease to the covers that have contacting area with the harness.	
4	<p>Refit the base cover.</p> <p> Note</p> <p>For robots with protection class IP54 (option 3350-540)</p> <p>For robots with protection type Clean Room (option 3351-1)</p> <p>Check the gasket for the base and the gasket for the base cover before refitting the base cover.</p> <p> Tip</p> <p>Replace the gasket if needed.</p>	 <p>xx1800002828</p> <p>For robots with protection class IP54 (option 3350-540)</p> <p>For robots with protection type Clean Room (option 3351-1)</p>  <p>xx1900001635</p>

Continues on next page

5 Repair

5.7.1 Replacing the axis-1 motor sub-assembly

Continued

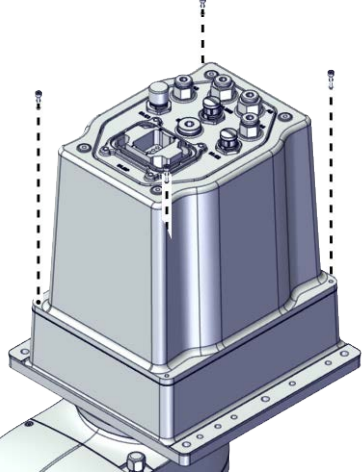
	Action	Note
5	Secure the base cover to the base with the screws.	<p>Screws: Hex socket head cap screw M3x12 12.9 Lafre 2C2B/FC6.9 (4 pcs) Tightening torque: 1.2 Nm \pm10%</p>  <p>xx1800002827</p>

Continues on next page

5.7.1 Replacing the axis-1 motor sub-assembly
Continued

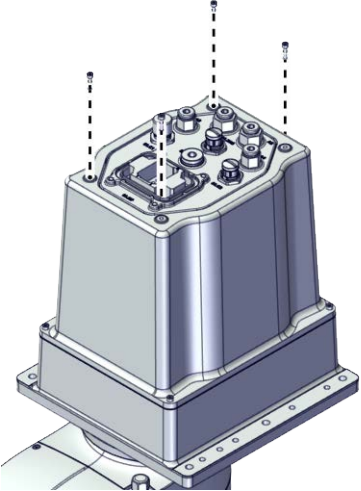
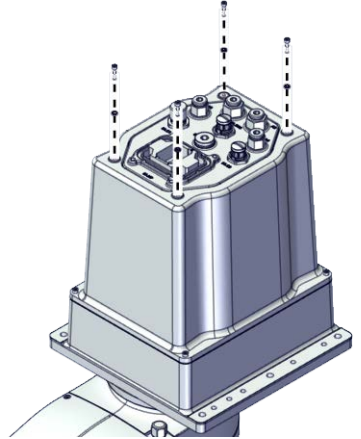
	Action	Note
6	<p>Secure the base harness to the base cover with the screws.</p> <p> Note</p> <p>For robots with protection class IP54 (option 3350-540)</p> <p>For robots with protection type Clean Room (option 3351-1)</p> <p>Refit the extra sealing washers on the base cover to the base harness.</p>	<p>For robots with protection class IP30 (option 3350-300)</p> <p>Screws: Hex socket head cap screw M3x12 12.9 Lafre 2C2B/FC6.9 (4 pcs)</p> <p>Tightening torque: 1.2 Nm ±10%</p>  <p>xx1800002826</p> <p>For robots with protection class IP54 (option 3350-540)</p> <p>For robots with protection type Clean Room (option 3351-1)</p> <p>Screws: Hex socket head cap screw M3x12 12.9 Lafre 2C2B/FC6.9 (4 pcs)</p> <p>Washers: Sealing washer M3 (4 pcs)</p> <p>Tightening torque: 1.2 Nm ±10%</p>  <p>xx1900001634</p>



Continues on next page

5 Repair

5.7.1 Replacing the axis-1 motor sub-assembly

Continued

Concluding procedure

	Action	Note
1	<p>For robots with protection type Clean Room: Seal and paint the joints that have been opened. See Cut the paint or surface on the robot before replacing parts on page 118</p> <p> Note</p> <p>After all repair work, wipe the Clean Room robot free from particles with spirit on a lint free cloth.</p>	
2	Recalibrate the robot.	Calibration is detailed in section Calibration on page 771 .
3	<p> DANGER</p> <p>Make sure all safety requirements are met when performing the first test run. See Test run after installation, maintenance, or repair on page 56.</p>	

5.7.2 Replacing the axis-2 motor sub-assembly

Location of the axis-2 motor sub-assembly

The axis-2 motor sub-assembly is located as shown in the figure.

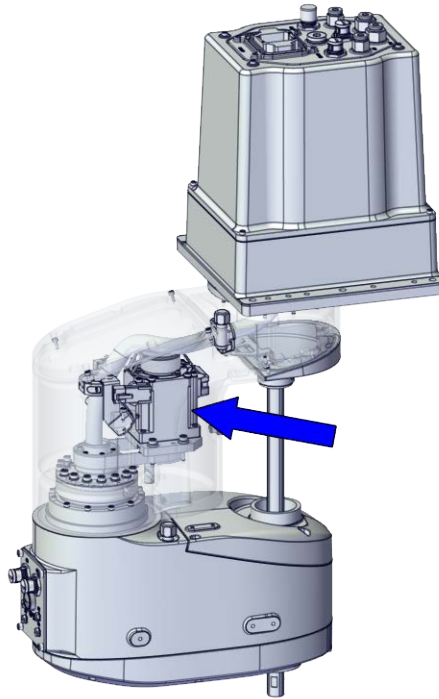

xx1800002872

Required spare parts



Note

The spare part numbers that are listed in the table can be out of date. See the latest spare parts of the IRB 910INV via myABB Business Portal, www.abb.com/myABB.

Spare part	Article number	Note
Axis-2 motor sub-assembly	3HAC083593-001	Used for IRB 910INV-3/0.35
Axis-2 motor sub-assembly	3HAC083595-001	Used for IRB 910INV-6/0.55
Timing belt	3HAC061861-001	

Required tools and equipment

Equipment	Article number	Note
Standard toolkit	-	Content is defined in section Standard toolkit on page 840 .

Continues on next page

5 Repair

5.7.2 Replacing the axis-2 motor sub-assembly

Continued

Equipment	Article number	Note
Calibration tool box, Axis Calibration	3HAC074119-001	Delivered as a set of calibration tools. Required if Axis Calibration is the valid calibration method for the robot. ⁱ
Sonic tension meter	-	Used for measuring the timing belt tension.
Handheld dynamometer	-	Used for measuring the timing belt tension.

- ⁱ The robot is calibrated by either manual calibration or Axis Calibration at ABB factory before delivery. Always use the same calibration method as used at the factory.
Information about valid calibration method is found on the calibration label or in the calibration menu on the FlexPendant.
If no data is found related to standard calibration, manual calibration is used as default.

Required consumables

Consumable	Article number	Note
Cable straps	-	
Grease	3HAC029132-001	FM 222 Used to lubricate the cable harness.

Deciding calibration routine

Decide which calibration routine to be used, based on the information in the table. Depending on which routine is chosen, action might be required prior to beginning the repair work of the robot, see the table.



	Action	Note
1	Decide which calibration routine to use for calibrating the robot. <ul style="list-style-type: none"> Reference calibration. External cable packages (DressPack) and tools can stay fitted on the robot. Fine calibration. All external cable packages (DressPack) and tools must be removed from the robot. 	
	If the robot is to be calibrated with reference calibration: Find previous reference values for the axis or create new reference values. These values are to be used after the repair procedure is completed, for calibration of the robot. If no previous reference values exist, and no new reference values can be created, then reference calibration is not possible.	Follow the instructions given in the reference calibration routine on the FlexPendant to create reference values. Creating new values requires possibility to move the robot. Read more about reference calibration for Axis Calibration in Reference calibration routine on page 798 .
	If the robot is to be calibrated with fine calibration: Remove all external cable packages (DressPack) and tools from the robot.	

Continues on next page

Removing the axis-2 motor sub-assembly

Use these procedures to remove the axis-2 motor sub-assembly.

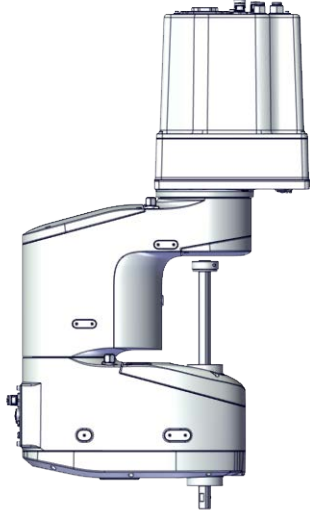
Preparations before removing the axis-2 motor sub-assembly

	Action	Note
1	Decide which calibration routine to use, and take actions accordingly prior to beginning the repair procedure.	
2	<p>If there is no enough space for the maintenance work, remove the robot from the wall and place it on the maintenance bracket.</p> <p> CAUTION</p> <p>Do not lay down the robot during the transportation, always keep it straight. If the robot lay down in any situation, the grease may come out from gearbox.</p>	
3	Jog all axes to zero position.	 <p>xx1800002825</p>
4	<p> DANGER</p> <p>Turn off all:</p> <ul style="list-style-type: none"> • electric power supply • hydraulic pressure supply • air pressure supply <p>to the robot, before entering the safeguarded space.</p>	
5	<p> CAUTION</p> <p>For robots with protection type Clean Room Always cut the paint with a knife and grind the paint edge when disassembling parts of the robot! See <i>Cut the paint or surface on the robot before replacing parts on page 118.</i></p>	



Continues on next page

5 Repair



5.7.2 Replacing the axis-2 motor sub-assembly

Continued

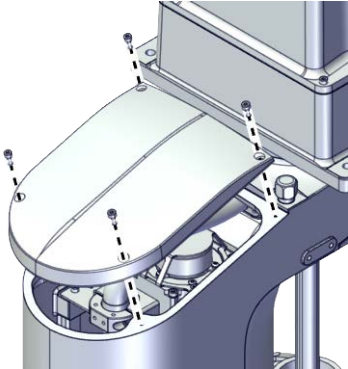
Removing the casting cover of the inner arm



	Action	Note
1	 DANGER Make sure that all supplies for electrical power, hydraulic pressure, and air pressure are turned off.	
2	 CAUTION For robots with protection type Clean Room Always cut the paint with a knife and grind the paint edge when disassembling parts of the robot! See Cut the paint or surface on the robot before replacing parts on page 118 .	
3	Remove the screws.	 xx1800002873
4	Remove the casting cover.	

Removing the cable bracket at the axis -2 motor position in the inner arm

	Action	Note
1	 DANGER Make sure that all supplies for electrical power, hydraulic pressure, and air pressure are turned off.	
2	 CAUTION For robots with protection type Clean Room Always cut the paint with a knife and grind the paint edge when disassembling parts of the robot! See Cut the paint or surface on the robot before replacing parts on page 118 .	

Continues on next page

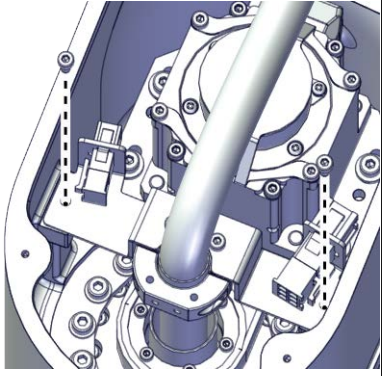
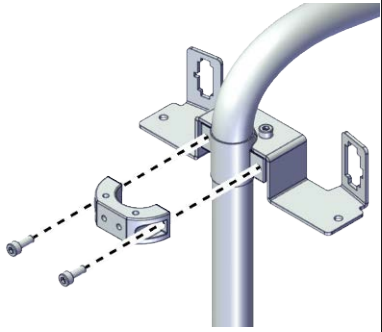
5.7.2 Replacing the axis-2 motor sub-assembly
Continued

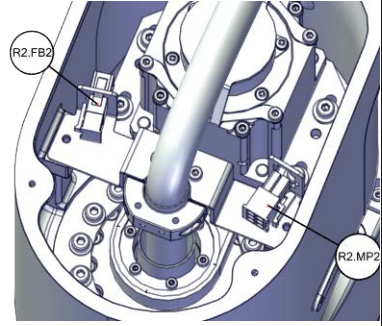
	Action	Note
3	Remove the screws.	 <p>xx1800002874</p>
4	Remove the screws on the cable ferrule to release the cable.	 <p>xx1800002876</p>
5	Disconnect the connectors. <ul style="list-style-type: none"> • R2.MP2 • R2.FB2  Tip Take photos of the connector and cable position before disconnecting them, to have as a reference when reconnecting.	 <p>xx1800002875</p>

Removing the axis-2 motor sub-assembly



	Action	Note
1	 DANGER Make sure that all supplies for electrical power, hydraulic pressure, and air pressure are turned off.	

Continues on next page

5 Repair

5.7.2 Replacing the axis-2 motor sub-assembly

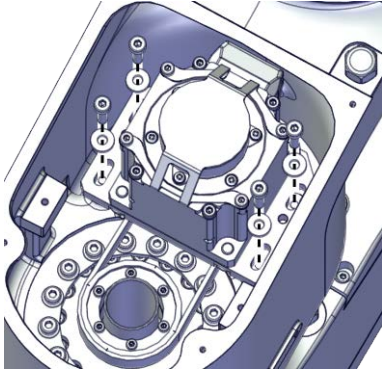
Continued

	Action	Note
2	 CAUTION For robots with protection type Clean Room Always cut the paint with a knife and grind the paint edge when disassembling parts of the robot! See Cut the paint or surface on the robot before replacing parts on page 118 .	
3	Remove the screws and washers.	 xx1800002877
4	Remove the motor and the timing belt.  Tip Move the internal harness out of the way.	

Refitting the axis-2 motor sub-assembly



Use these procedures to refit the axis-2 motor sub-assembly.

Refitting the axis-2 motor sub-assembly

	Action	Note
1	For robots with protection type Clean Room: Clean the joints that have been opened and wipe the parts free from particles with spirit on a lint free. See Cut the paint or surface on the robot before replacing parts on page 118  Note After all repair work, wipe the Clean Room robot free from particles with spirit on a lint free cloth.	

Continues on next page

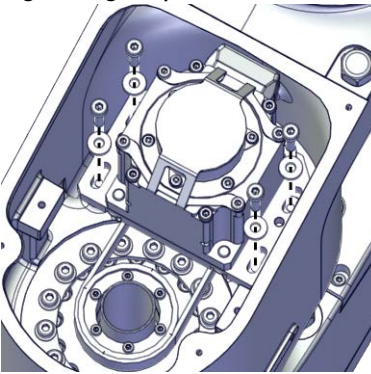
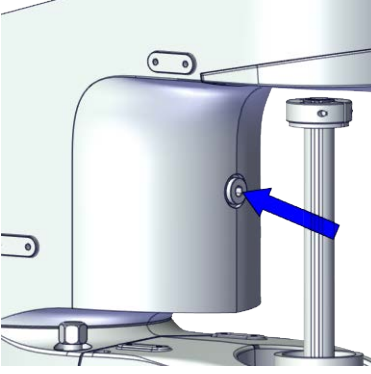
5.7.2 Replacing the axis-2 motor sub-assembly
Continued

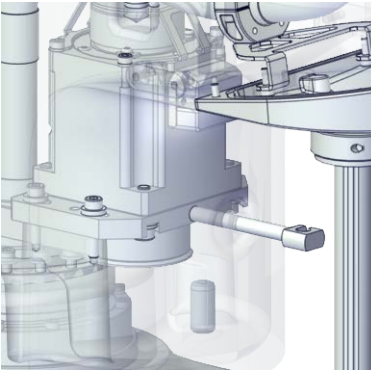



	Action	Note
2	Refit the axis-2 timing belt onto the pulley on the axis-2 gearbox.	Screws: Hex socket head cap screw M4x20 12.9 Lafre 2C2B/FC6.9 (4 pcs)
3	Refit the motor and refit the timing belt to the motor. Ensure that the belt runs correctly in the grooves.  Tip Move the internal harness out of the way.	Washers: Washer 4.3x10x2 steel (4 pcs) Tightening torque: 3 Nm \pm 10%  xx1800002877
4	Refit the screws and washers without fully tightened.	Timing belt: 3HAC061861-001
5	Remove the plug.	 xx1800002878
6	Install the axis-1&2 belt tension adjustment tool to the motor through the hole.  Note Just tighten the tool.	Belt tension adjustment tool set, axis 1&2:-  xx1800002879

Continues on next page

5 Repair



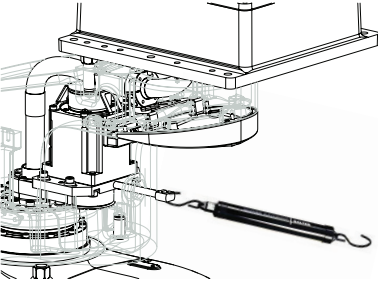
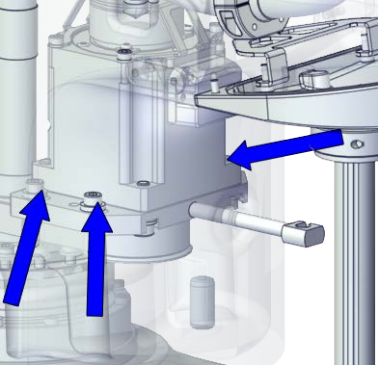

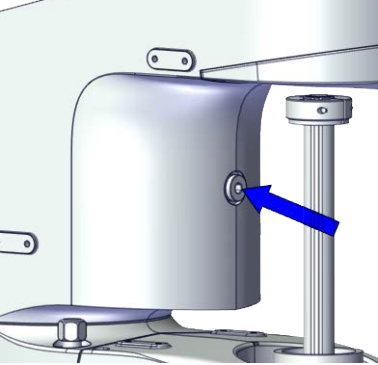
5.7.2 Replacing the axis-2 motor sub-assembly

Continued

	Action	Note
7	<p>Use a handheld dynamometer hooking to the screw and pull the dynamometer to make the tension falling in the allowed force range.</p> <p> Note</p> <p>During the measurement, make sure that all interferences that may affect the force are removed. Pay attention to the force application direction.</p> <p> Tip</p> <p>If the ball screw will interfere with the handheld dynamometer, adjust the ball screw manually.</p>	<p>Used belt: 45-51N New belt:65-71N</p>  <p>xx1900000095</p>
8	<p>Fasten the screws to the recommended tightening torque.</p>	<p>Tightening torque: 3 Nm \pm10%</p>  <p>xx1800002880</p>
9	<p>Use a sonic tension meter to measure the timing belt tension.</p>	<p>Used belt: 193-236Hz New belt:229-293Hz</p>
10	<p>If the timing belt tension does not meet the requirement, loosen the motor screws and readjust.</p>	
11	<p>Remove the axis-1&2 belt tension adjustment tool.</p>	
12	<p>Refit the plug.</p> <p> Tip</p> <p>Just tighten it.</p>	<p>Tightening torque: 2 Nm \pm10%</p>  <p>xx1800002878</p>

Continues on next page

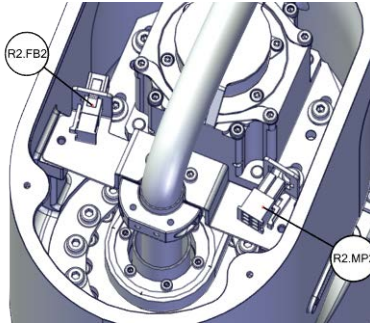
Refitting the cable bracket

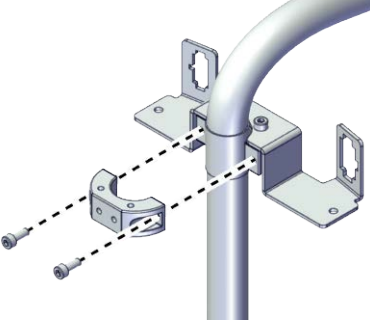
	Action	Note
1	<p>For robots with protection type Clean Room: Clean the joints that have been opened and wipe the parts free from particles with spirit on a lint free. See Cut the paint or surface on the robot before replacing parts on page 118</p> <p> Note</p> <p>After all repair work, wipe the Clean Room robot free from particles with spirit on a lint free cloth.</p>	
2	<p>Reconnect the connectors.</p> <ul style="list-style-type: none"> • R2.MP2 • R2.FB2 <p> Tip</p> <p>Take photos of the connector and cable position before disconnecting them, to have as a reference when reconnecting.</p> <p> Tip</p> <p>See the number markings on the connectors for help to find the corresponding connector.</p>	 <p>xx1800002875</p>
3	<p>Lay the internal harness in a natural state without distortion.</p>	
4	<p>Refit the cable ferrule on the cable at the marked position and secure with screws.</p> <p> Tip</p> <p>The position with wrapped tape is the marked position for the cable ferrule.</p> <p> Tip</p> <p>Align all the cable ferrules so that the cable is in a natural bending position to avoid twisting.</p>	<p>Screws: Hex socket head cap screw M3x8 12.9 Lafre 2C2B/FC6.9 (2 pcs)</p> <p>Tightening torque: 1.5 Nm ±10%</p>  <p>xx1800002876</p>

Continues on next page

5 Repair

5.7.2 Replacing the axis-2 motor sub-assembly

Continued

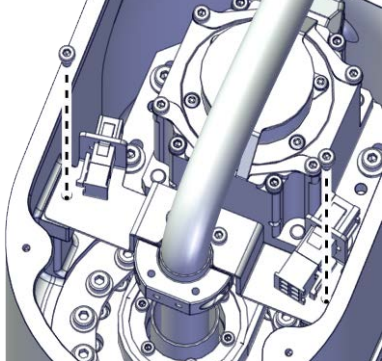

	Action	Note
5	Refit the bracket and secure with the screws.	<p>Screws: Hex socket head cap screw M3x5 12.9 Lafre 2C2B/FC6.9 (2 pcs) Tightening torque: 1.5 Nm \pm10%</p>  <p>xx1800002874</p>

Refitting the casting cover of the inner arm

	Action	Note
1	<p>For robots with protection type Clean Room: Clean the joints that have been opened and wipe the parts free from particles with spirit on a lint free. See Cut the paint or surface on the robot before replacing parts on page 118</p> <p> Note</p> <p>After all repair work, wipe the Clean Room robot free from particles with spirit on a lint free cloth.</p>	

Continues on next page

5.7.2 Replacing the axis-2 motor sub-assembly
Continued

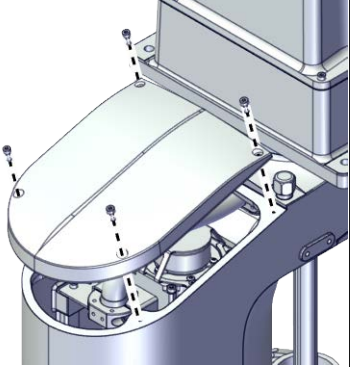
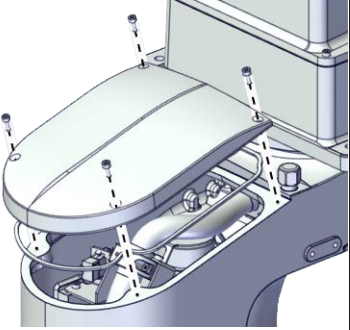
	Action	Note
2	<p>Refit the casting cover.</p> <p> Note</p> <p>For robots with protection class IP54 (option 3350-540)</p> <p>For robots with protection type Clean Room (option 3351-1)</p> <p>Check the gasket for the casting cover before refitting the base cover.</p> <p> Tip</p> <p>Replace the gasket if needed.</p>	<p>Screw: Hex socket head cap screw M3x8 12.9 Lafre 2C2B/FC6.9 (4 pcs)</p> <p>Tightening torque: 1.2 Nm ±10%</p> <p>For robots with protection class IP30 (option 3350-300)</p>  <p>xx1800002873</p>
3	<p>Refit the screws.</p>	<p>For robots with protection class IP54 (option 3350-540)</p> <p>For robots with protection type Clean Room (option 3351-1)</p>  <p>xx1900001637</p>

Concluding procedure

	Action	Note
1	<p>For robots with protection type Clean Room: Seal and paint the joints that have been opened. See Cut the paint or surface on the robot before replacing parts on page 118</p> <p> Note</p> <p>After all repair work, wipe the Clean Room robot free from particles with spirit on a lint free cloth.</p>	
2	<p>Recalibrate the robot.</p>	<p>Calibration is detailed in section Calibration on page 771.</p>

Continues on next page

5 Repair

5.7.2 Replacing the axis-2 motor sub-assembly

Continued

	Action	Note
3	 DANGER Make sure all safety requirements are met when performing the first test run. See Test run after installation, maintenance, or repair on page 56 .	

5.7.3 Replacing the axis-3 motor sub-assembly

Location of the axis-3 motor sub-assembly

The axis-3 motor sub-assembly is located as shown in the figure.

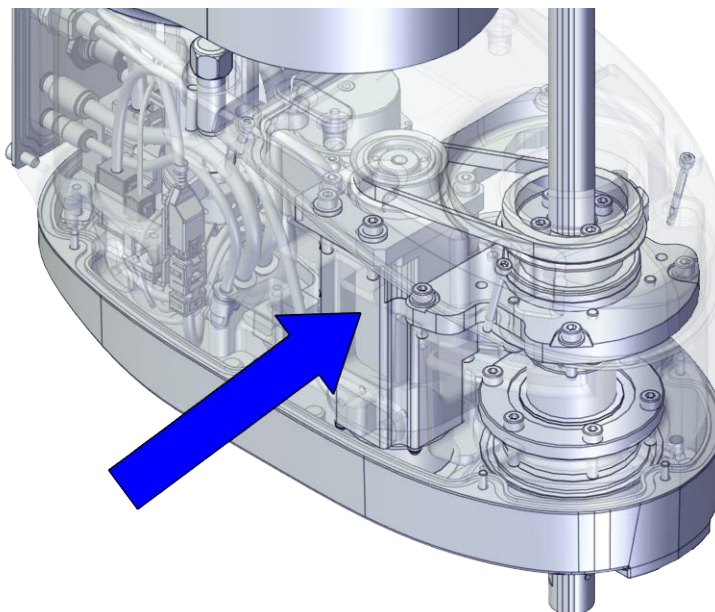

xx1800002881

Required spare parts



Note

The spare part numbers that are listed in the table can be out of date. See the latest spare parts of the IRB 910INV via myABB Business Portal, www.abb.com/myABB.

Spare part	Article number	Note
Axis-3 motor sub-assembly	3HAC083594-001	
Timing belt	3HAC061862-001	

Required tools and equipment

Equipment	Article number	Note
Standard toolkit	-	Content is defined in section Standard toolkit on page 840 .
Calibration tool box, Axis Calibration	3HAC074119-001	Delivered as a set of calibration tools. Required if Axis Calibration is the valid calibration method for the robot. ⁱ
24 VDC power supply	-	Used to release the motor brakes.

Continues on next page

5 Repair

5.7.3 Replacing the axis-3 motor sub-assembly

Continued

Equipment	Article number	Note
Sonic tension meter	-	Used for measuring the timing belt tension.
Handheld dynamometer	-	Used for measuring the timing belt tension.

- i The robot is calibrated by either manual calibration or Axis Calibration at ABB factory before delivery. Always use the same calibration method as used at the factory.
Information about valid calibration method is found on the calibration label or in the calibration menu on the FlexPendant.
If no data is found related to standard calibration, manual calibration is used as default.

Required consumables

Consumable	Article number	Note
Cable straps	-	
Grease	3HAC029132-001	FM 222 Used to lubricate the cable harness.

Deciding calibration routine

Decide which calibration routine to be used, based on the information in the table. Depending on which routine is chosen, action might be required prior to beginning the repair work of the robot, see the table.



	Action	Note
1	Decide which calibration routine to use for calibrating the robot. <ul style="list-style-type: none"> Reference calibration. External cable packages (DressPack) and tools can stay fitted on the robot. Fine calibration. All external cable packages (DressPack) and tools must be removed from the robot. 	
	If the robot is to be calibrated with reference calibration: Find previous reference values for the axis or create new reference values. These values are to be used after the repair procedure is completed, for calibration of the robot. If no previous reference values exist, and no new reference values can be created, then reference calibration is not possible.	Follow the instructions given in the reference calibration routine on the FlexPendant to create reference values. Creating new values requires possibility to move the robot. Read more about reference calibration for Axis Calibration in Reference calibration routine on page 798 .
	If the robot is to be calibrated with fine calibration: Remove all external cable packages (DressPack) and tools from the robot.	

Continues on next page

Removing the axis-3 motor sub-assembly

Use these procedures to remove the axis-3 motor sub-assembly.

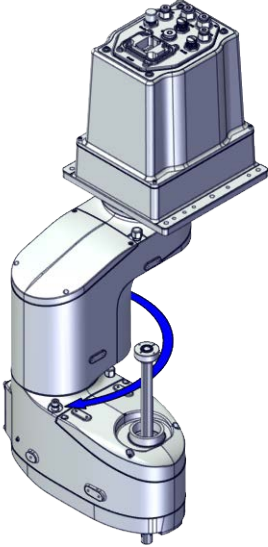
Preparations before removing the axis-3 motor sub-assembly

	Action	Note
1	Decide which calibration routine to use, and take actions accordingly prior to beginning the repair procedure.	
2	<p>If there is no enough space for the maintenance work, remove the robot from the wall and place it on the maintenance bracket.</p> <p> CAUTION</p> <p>Do not lay down the robot during the transportation, always keep it straight. If the robot lay down in any situation, the grease may come out from gearbox.</p>	
3	Jog the outer arm to access the casting cover screws.	 <p>xx1800003407</p>
4	<p> DANGER</p> <p>Turn off all:</p> <ul style="list-style-type: none"> • electric power supply • hydraulic pressure supply • air pressure supply <p>to the robot, before entering the safeguarded space.</p>	

Continues on next page



5 Repair

5.7.3 Replacing the axis-3 motor sub-assembly

Continued

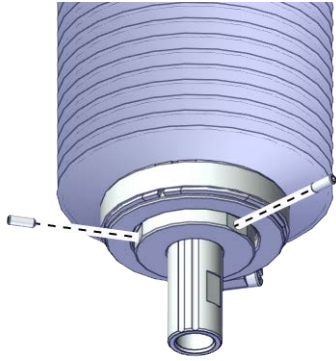
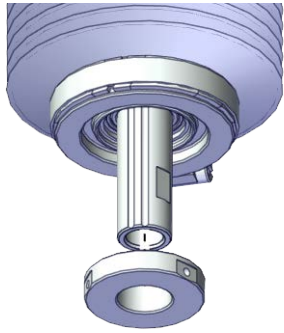

	Action	Note
5	 CAUTION For robots with protection type Clean Room Always cut the paint with a knife and grind the paint edge when disassembling parts of the robot! See Cut the paint or surface on the robot before replacing parts on page 118 .	

Removing the lower cover

	Action	Note
1	 DANGER Make sure that all supplies for electrical power, hydraulic pressure, and air pressure are turned off.	
2	 CAUTION For robots with protection type Clean Room Always cut the paint with a knife and grind the paint edge when disassembling parts of the robot! See Cut the paint or surface on the robot before replacing parts on page 118 .	
3	For robots with protection class IP54 (option 3350-540) For robots with protection type Clean Room (option 3351-1) Loose the locking screws.	 xx1900001606
4	For robots with protection class IP54 (option 3350-540) For robots with protection type Clean Room (option 3351-1) Remove the lower cover from the ball screw.	 xx1900001607

Continues on next page

Removing the cover of the outer arm





	Action	Note
1	 DANGER Make sure that all supplies for electrical power, hydraulic pressure, and air pressure are turned off.	
2	 CAUTION For robots with protection type Clean Room Always cut the paint with a knife and grind the paint edge when disassembling parts of the robot! See <i>Cut the paint or surface on the robot before replacing parts on page 118.</i>	

Continues on next page

5 Repair

5.7.3 Replacing the axis-3 motor sub-assembly

Continued

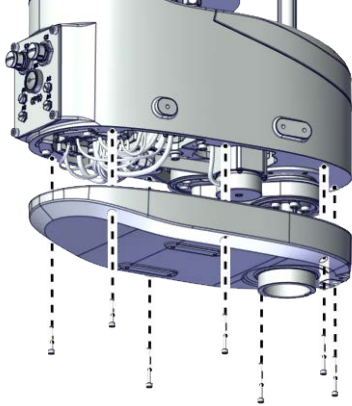
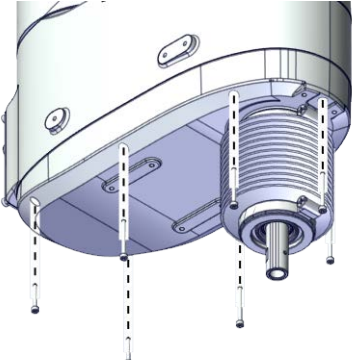
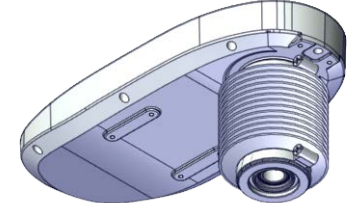
	Action	Note
3	<p>Remove the screws on the cover of the outer arm and remove the cover.</p> <p> Note</p> <p>For robots with protection class IP54 (option 3350-540)</p> <p>For robots with protection type Clean Room (option 3351-1)</p> <p>Remove the cover with bellow and housing.</p> <p> Note</p> <p>The bellow does not need to be removed separately.</p> <p> CAUTION</p> <p>There is a gasket in the cover. Be careful when removing the cover with bellow and housing.</p> <p> Tip</p> <p>Check the gasket and replace it if needed.</p>	<p>For robots with protection class IP30 (option 3350-300)</p>  <p>xx1800002836</p> <p>For robots with protection class IP54 (option 3350-540)</p> <p>For robots with protection type Clean Room (option 3351-1)</p>  <p>xx1900001631</p>  <p>xx1900001632</p>

Removing the bracket for the process hub



	Action	Note
1	<p> DANGER</p> <p>Make sure that all supplies for electrical power, hydraulic pressure, and air pressure are turned off.</p>	

Continues on next page

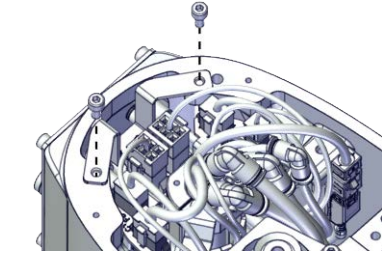
5.7.3 Replacing the axis-3 motor sub-assembly
Continued

	Action	Note
2	 CAUTION For robots with protection type Clean Room Always cut the paint with a knife and grind the paint edge when disassembling parts of the robot! See <i>Cut the paint or surface on the robot before replacing parts on page 118.</i>	
3	Remove the screws on the bracket and take it out carefully.	 <p>xx1800002839</p>

Disconnecting the connectors for axis-3 motor

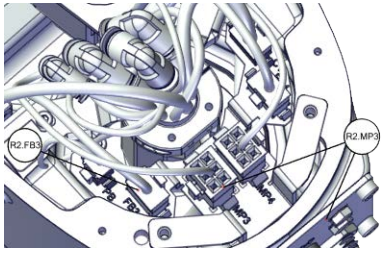
	Action	Note
1	 DANGER Make sure that all supplies for electrical power, hydraulic pressure, and air pressure are turned off.	
2	 CAUTION For robots with protection type Clean Room Always cut the paint with a knife and grind the paint edge when disassembling parts of the robot! See <i>Cut the paint or surface on the robot before replacing parts on page 118.</i>	
3	Disconnect the connectors. <ul style="list-style-type: none"> • R2.MP3 • R2.FB3 	 <p>xx1900000063</p>

Continues on next page



5 Repair

5.7.3 Replacing the axis-3 motor sub-assembly

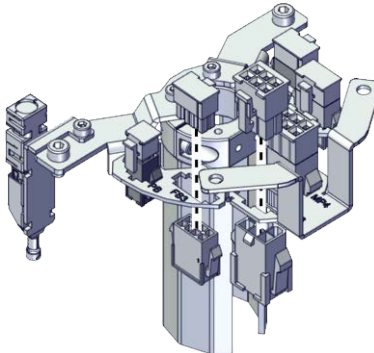
Continued

	Action	Note
4	Snap loose and remove the female head of the connectors from the bracket.	 <p data-bbox="1029 672 1141 694">xx190000064</p>

Removing the upper cover

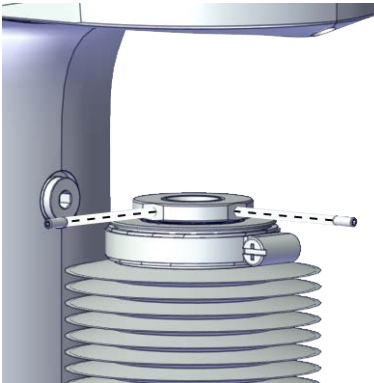

	Action	Note
1	 <p data-bbox="566 873 678 907">DANGER</p> <p data-bbox="478 929 1013 1019">Make sure that all supplies for electrical power, hydraulic pressure, and air pressure are turned off.</p>	
2	 <p data-bbox="566 1075 686 1108">CAUTION</p> <p data-bbox="478 1131 1013 1265">For robots with protection type Clean Room Always cut the paint with a knife and grind the paint edge when disassembling parts of the robot! See Cut the paint or surface on the robot before replacing parts on page 118.</p>	
3	<p data-bbox="478 1310 1013 1355">For robots with protection class IP54 (option 3350-540)</p> <p data-bbox="478 1366 1013 1422">For robots with protection type Clean Room (option 3351-1)</p> <p data-bbox="478 1433 774 1456">Loose the locking screws.</p>	 <p data-bbox="1029 1691 1141 1713">xx1900001547</p>

Continues on next page

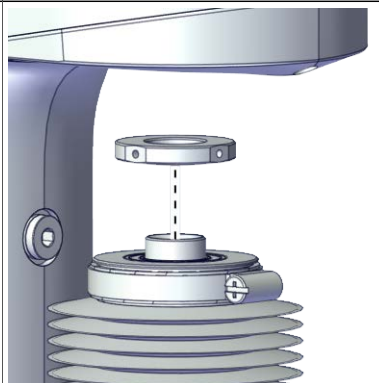
5.7.3 Replacing the axis-3 motor sub-assembly
Continued

	Action	Note
4	<p>For robots with protection class IP54 (option 3350-540) For robots with protection type Clean Room (option 3351-1) Remove the upper cover from the ball screw.</p>	 <p>xx1900001548</p>

Removing the casting cover of the outer arm





	Action	Note
1	<p> DANGER</p> <p>Make sure that all supplies for electrical power, hydraulic pressure, and air pressure are turned off.</p>	
2	<p> CAUTION</p> <p>For robots with protection type Clean Room Always cut the paint with a knife and grind the paint edge when disassembling parts of the robot! See Cut the paint or surface on the robot before replacing parts on page 118.</p>	

Continues on next page

5 Repair

5.7.3 Replacing the axis-3 motor sub-assembly

Continued

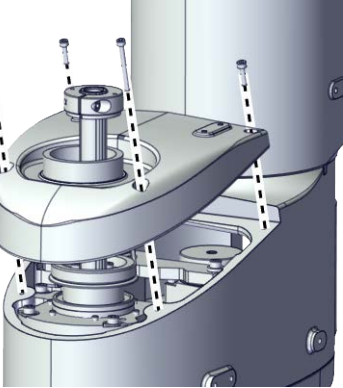
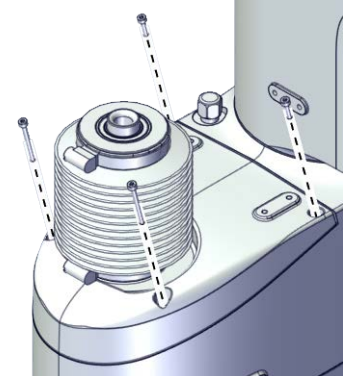
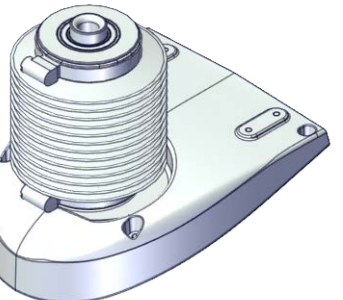

	Action	Note
3	<p>Remove the screws on the casting cover of the outer arm and remove the cover.</p> <p> Note</p> <p>For robots with protection class IP54 (option 3350-540)</p> <p>For robots with protection type Clean Room (option 3351-1)</p> <p>Remove the cover with bellow and housing.</p> <p> Note</p> <p>The bellow does not need to be removed separately.</p> <p> CAUTION</p> <p>There is a gasket in the cover. Be careful when removing the cover with bellow and housing.</p> <p> Tip</p> <p>Check the gasket and replace it if needed.</p>	<p>For robots with protection class IP30 (option 3350-300)</p>  <p>xx1800002883</p> <p>For robots with protection class IP54 (option 3350-540)</p> <p>For robots with protection type Clean Room (option 3351-1)</p>  <p>xx1900001628</p>  <p>xx1900001629</p>

Removing the axis-3 motor sub-assembly

	Action	Note
1	<p> DANGER</p> <p>Make sure that all supplies for electrical power, hydraulic pressure, and air pressure are turned off.</p>	

Continues on next page

5.7.3 Replacing the axis-3 motor sub-assembly
Continued

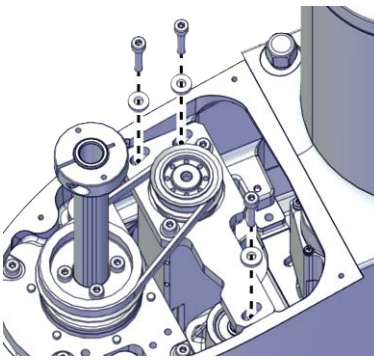
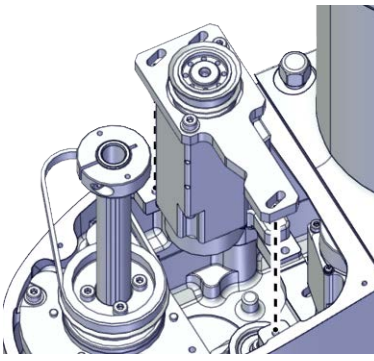
	Action	Note
2	<p> CAUTION</p> <p>For robots with protection type Clean Room Always cut the paint with a knife and grind the paint edge when disassembling parts of the robot! See <i>Cut the paint or surface on the robot before replacing parts on page 118.</i></p>	
3	<p> DANGER</p> <p>Make sure that the ball screw is supported with something. The sudden drop of the ball screw due the lost of the axis-3 motor may cause danger.</p>	
4	Remove the screws.	 <p>xx1800002884</p>
5	Remove the axis-3 motor sub-assembly and the timing belt.	 <p>xx1800002885</p>

Continues on next page

5 Repair



5.7.3 Replacing the axis-3 motor sub-assembly

Continued

Refitting the axis-3 motor sub-assembly

Use these procedures to refit the axis-3 motor sub-assembly.

Refitting the axis-3 motor sub-assembly

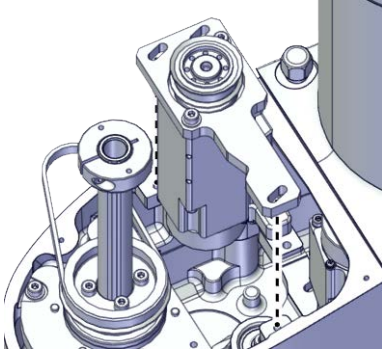
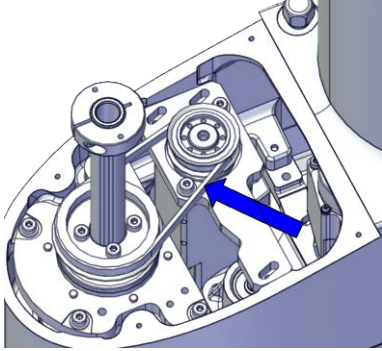
	Action	Note
1	<p>For robots with protection type Clean Room: Clean the joints that have been opened and wipe the parts free from particles with spirit on a lint free. See Cut the paint or surface on the robot before replacing parts on page 118</p> <p> Note</p> <p>After all repair work, wipe the Clean Room robot free from particles with spirit on a lint free cloth.</p>	
2	<p>Refit the motor to the outer arm.</p> <p> Tip</p> <p>Move the internal harness out of the way.</p>	 xx1800002885
3	<p>Refit the timing belt to the pulley on the ball screw and the motor. Ensure that the belt runs correctly in the grooves.</p>	<p>Timing belt: 3HAC061862-001</p>  xx1800002886

Continues on next page

5.7.3 Replacing the axis-3 motor sub-assembly
Continued

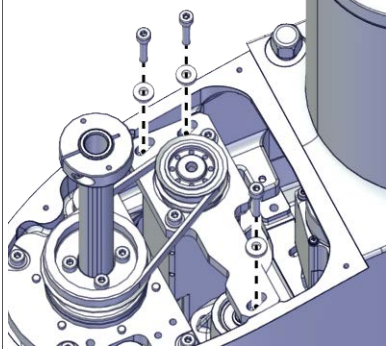
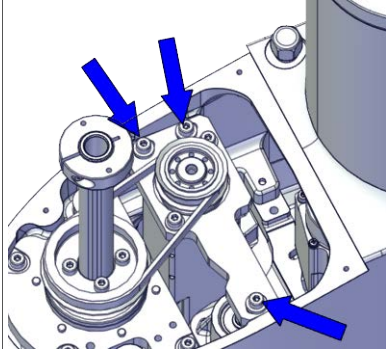
	Action	Note
4	Refit the screws and washers.	<p>Screws: Hex socket head cap screw M4x20 12.9 Lafre 2C2B/FC6.9 (3 pcs) Washers: Washer 4.3x10x2 steel (3 pcs) Tightening torque: 3 Nm ±10%</p>  <p>xx1800002884</p>
5	Use a sonic tension meter to measure the timing belt tension.	<p>Used belt: 190-232Hz New belt: 225-287Hz</p>
6	If the timing belt tension does not meet the requirement, loosen the motor screws and readjust.	 <p>xx1800002887</p>

Refitting the casting cover of the outer arm



	Action	Note
1	<p>For robots with protection type Clean Room: Clean the joints that have been opened and wipe the parts free from particles with spirit on a lint free. See Cut the paint or surface on the robot before replacing parts on page 118</p> <p> Note</p> <p>After all repair work, wipe the Clean Room robot free from particles with spirit on a lint free cloth.</p>	

Continues on next page

5 Repair

5.7.3 Replacing the axis-3 motor sub-assembly

Continued

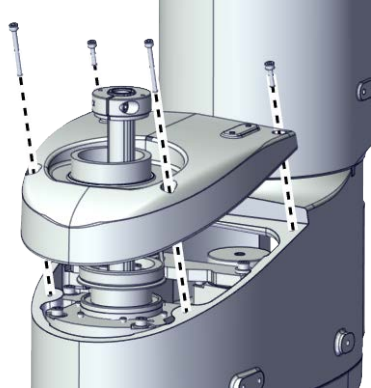
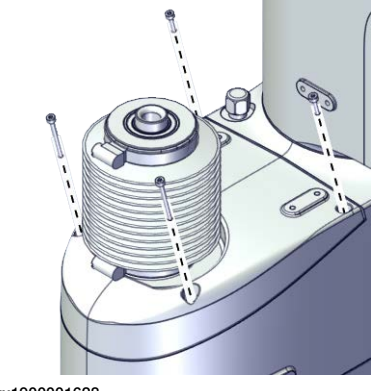
	Action	Note
2	<p>Refit the cover.</p> <p> Note</p> <p>For robots with protection class IP54 (option 3350-540)</p> <p>For robots with protection type Clean Room (option 3351-1)</p> <p>Refit the cover with bellow and housing.</p> <p>Check the gasket on the casting cover.</p> <p> CAUTION</p> <p>There is a gasket in the cover. Be careful when refitting the cover with bellow and housing.</p> <p> Tip</p> <p>Replace the gasket if needed.</p>	<p>Long screw: Hex socket head cap screw M3x30 12.9 Lafre 2C2B/FC6.9 (2 pcs)</p> <p>Tightening torque: 1.2 Nm ±10%</p> <p>Short screw: Hex socket head cap screw M3x12 12.9 Lafre 2C2B/FC6.9 (2 pcs)</p> <p>Tightening torque: 1.2 Nm ±10%</p> <p>For robots with protection class IP30 (option 3350-300)</p>  <p>xx1800002883</p>
3	<p>Refit the screws.</p>	<p>For robots with protection class IP54 (option 3350-540)</p> <p>For robots with protection type Clean Room (option 3351-1)</p>  <p>xx1900001628</p>

Refitting the upper cover



	Action	Note
1	<p>For robots with protection type Clean Room:</p> <p>Clean the joints that have been opened and wipe the parts free from particles with spirit on a lint free. See Cut the paint or surface on the robot before replacing parts on page 118</p> <p> Note</p> <p>After all repair work, wipe the Clean Room robot free from particles with spirit on a lint free cloth.</p>	

Continues on next page

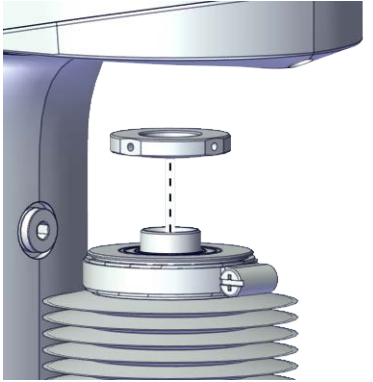
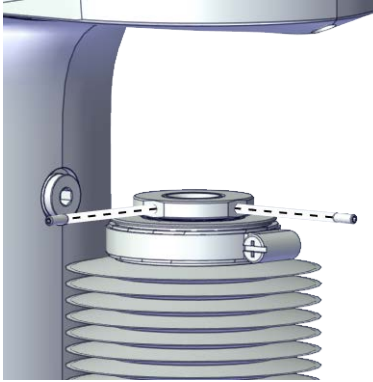
5.7.3 Replacing the axis-3 motor sub-assembly
Continued

	Action	Note
2	<p>For robots with protection class IP54 (option 3350-540) For robots with protection type Clean Room (option 3351-1) Refit the upper cover to the ball screw.</p>	 <p>xx1900001548</p>
3	<p>For robots with protection class IP54 (option 3350-540) For robots with protection type Clean Room (option 3351-1) Refit the locking screws.</p>	<p>Screws: Hexagon socket set screws with flat point, ISO 4026 stainless steel M3x8 (2 pcs) Tightening torque: 0.6 Nm ±10%</p>  <p>xx1900001547</p>

Reconnecting the connectors for axis-3 motor



	Action	Note
1	<p>For robots with protection type Clean Room: Clean the joints that have been opened and wipe the parts free from particles with spirit on a lint free. See Cut the paint or surface on the robot before replacing parts on page 118</p> <p> Note After all repair work, wipe the Clean Room robot free from particles with spirit on a lint free cloth.</p>	
2	<p>Route the cabling on the axis-3 motor behind the protected bracket to the bracket.</p> <p> CAUTION Correct cable routing is highly important. If the cables are routed and secured incorrectly the cables can be damaged.</p>	

Continues on next page

5 Repair

5.7.3 Replacing the axis-3 motor sub-assembly

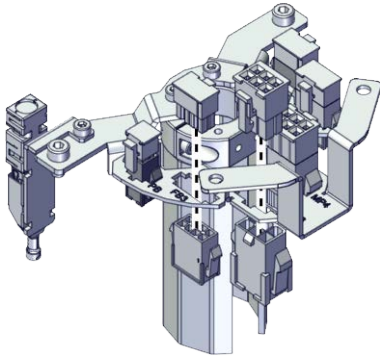
Continued

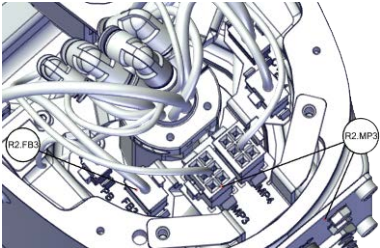
	Action	Note
3	<p>Insert the female head of the connectors to the bracket accordingly.</p> <p> Tip</p> <p>The mistake proofing measure has been applied to the connectors, the connectors may be damaged if excessive force is used.</p>	 <p>xx1900000064</p>
4	<p>Reconnect the connectors.</p> <ul style="list-style-type: none"> • R2.MP3 • R2.FB3 <p> Tip</p> <p>See the number markings on the connectors for help to find the corresponding connector.</p>	 <p>xx1900000063</p>

Refitting the bracket for the process hub

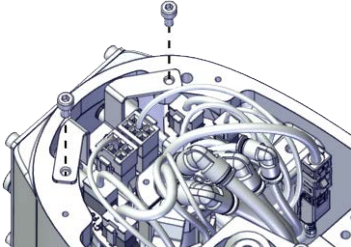
	Action	Note
1	<p>For robots with protection type Clean Room: Clean the joints that have been opened and wipe the parts free from particles with spirit on a lint free. See Cut the paint or surface on the robot before replacing parts on page 118</p> <p> Note</p> <p>After all repair work, wipe the Clean Room robot free from particles with spirit on a lint free cloth.</p>	
2	<p>Secure the bracket with screws.</p>	<p>Screws: Hex socket head cap screw M4x8 12.9 Lafre 2C2B/FC6.9 (2 pcs)</p> <p>Tightening torque: 4 Nm \pm10%</p>  <p>xx1800002839</p>

Continues on next page

Refitting the cover of the outer arm



	Action	Note
1	<p>For robots with protection type Clean Room: Clean the joints that have been opened and wipe the parts free from particles with spirit on a lint free. See Cut the paint or surface on the robot before replacing parts on page 118</p> <p> Note</p> <p>After all repair work, wipe the Clean Room robot free from particles with spirit on a lint free cloth.</p>	

Continues on next page

5 Repair

5.7.3 Replacing the axis-3 motor sub-assembly

Continued

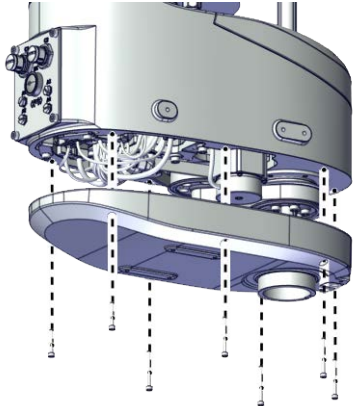
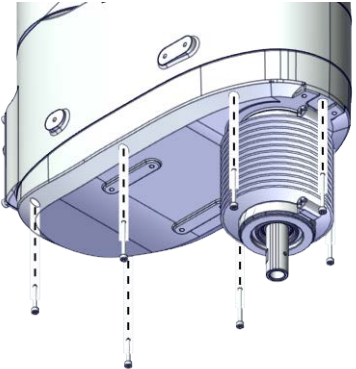
	Action	Note
2	<p>Refit the cover.</p> <p> Note</p> <p>For robots with protection class IP54 (option 3350-540)</p> <p>For robots with protection type Clean Room (option 3351-1)</p> <p>Refit the cover with bellow and housing.</p> <p>Check the gasket on the outer arm cover.</p> <p> Tip</p> <p>Replace the gasket if needed.</p>	<p>For IRB 910INV-3/0.35:</p> <p>Screw: Hex socket head cap screw M3x20 12.9 Lafre 2C2B/FC6.9 (2 pcs)</p> <p>Hex socket head cap screw M3x30 12.9 Lafre 2C2B/FC6.9 (5 pcs)</p> <p>Tightening torque: 1.2 Nm ±10%</p> <p>For IRB 910INV-6/0.55:</p> <p>Screw: Hex socket head cap screw M3x20 12.9 Lafre 2C2B/FC6.9 (2 pcs)</p> <p>Hex socket head cap screw M3x30 12.9 Lafre 2C2B/FC6.9 (7 pcs)</p> <p>Tightening torque: 1.2 Nm ±10%</p> <p>For robots with protection class IP30 (option 3350-300)</p>
3	<p>Refit the screws.</p>	 <p>xx1800002836</p> <p>For robots with protection class IP54 (option 3350-540)</p> <p>For robots with protection type Clean Room (option 3351-1)</p>  <p>xx1900001631</p>

Continues on next page

Refitting the lower cover

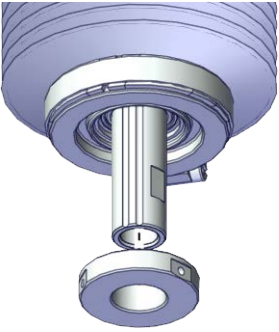
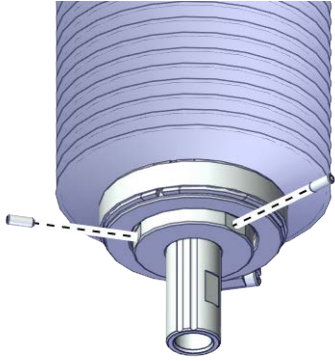
	Action	Note
1	<p>For robots with protection type Clean Room: Clean the joints that have been opened and wipe the parts free from particles with spirit on a lint free. See Cut the paint or surface on the robot before replacing parts on page 118</p> <p> Note</p> <p>After all repair work, wipe the Clean Room robot free from particles with spirit on a lint free cloth.</p>	
2	<p>For robots with protection class IP54 (option 3350-540) For robots with protection type Clean Room (option 3351-1) Refit the lower cover to the ball screw.</p>	 <p>xx1900001607</p>
3	<p>For robots with protection class IP54 (option 3350-540) For robots with protection type Clean Room (option 3351-1) Refit the locking screws.</p>	<p>Screws: Hexagon socket set screws with flat point, ISO 4026 stainless steel M3x8 (2 pcs) Tightening torque: 0.6 Nm ±10%</p>  <p>xx1900001606</p>



Continues on next page

5 Repair

5.7.3 Replacing the axis-3 motor sub-assembly

Continued

Concluding procedure

	Action	Note
1	<p>For robots with protection type Clean Room: Seal and paint the joints that have been opened. See Cut the paint or surface on the robot before replacing parts on page 118</p> <p> Note</p> <p>After all repair work, wipe the Clean Room robot free from particles with spirit on a lint free cloth.</p>	
2	Recalibrate the robot.	Calibration is detailed in section Calibration on page 771 .
3	<p> DANGER</p> <p>Make sure all safety requirements are met when performing the first test run. See Test run after installation, maintenance, or repair on page 56.</p>	

5.7.4 Replacing the axis-4 motor sub-assembly

Location of the axis-4 motor sub-assembly

The axis-4 motor sub-assembly is located as shown in the figure.

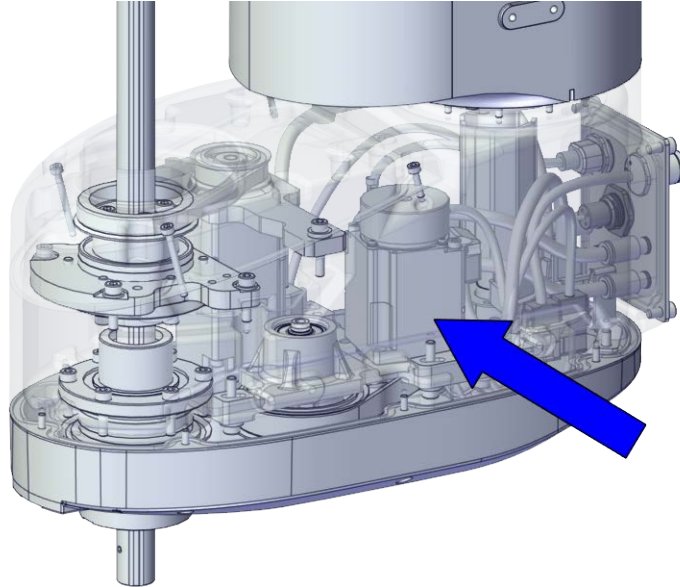

xx1800002882

Required spare parts



Note

The spare part numbers that are listed in the table can be out of date. See the latest spare parts of the IRB 910INV via myABB Business Portal, www.abb.com/myABB.

Spare part	Article number	Note
Axis-4 motor sub-assembly	3HAC083592-001	Used for IRB 910INV-3/0.35
Axis-4 motor sub-assembly	3HAC083590-001	Used for IRB 910INV-6/0.55
Timing belt	3HAC061863-001	
Timing belt	3HAC061864-001	
Pulley pre-assembly	3HAC073057-001	

Required tools and equipment

Equipment	Article number	Note
Standard toolkit	-	Content is defined in section Standard toolkit on page 840 .

Continues on next page

5 Repair

5.7.4 Replacing the axis-4 motor sub-assembly

Continued

Equipment	Article number	Note
Calibration tool box, Axis Calibration	3HAC074119-001	Delivered as a set of calibration tools. Required if Axis Calibration is the valid calibration method for the robot. ⁱ
24 VDC power supply	-	Used to release the motor brakes.
Belt tension adjustment tool set, stage two of axis 4	-	Included in the special toolkit 3HAC073070-001. Used to adjust the tension of axis-4 timing belt. Special tool for L2
Sonic tension meter	-	Used for measuring the timing belt tension.
Handheld dynamometer	-	Used for measuring the timing belt tension.

ⁱ The robot is calibrated by either manual calibration or Axis Calibration at ABB factory before delivery. Always use the same calibration method as used at the factory. Information about valid calibration method is found on the calibration label or in the calibration menu on the FlexPendant. If no data is found related to standard calibration, manual calibration is used as default.

Required consumables

Consumable	Article number	Note
Cable straps	-	
Grease	3HAC029132-001	FM 222 Used to lubricate the cable harness.

Deciding calibration routine

Decide which calibration routine to be used, based on the information in the table. Depending on which routine is chosen, action might be required prior to beginning the repair work of the robot, see the table.

	Action	Note
1	Decide which calibration routine to use for calibrating the robot. <ul style="list-style-type: none"> Reference calibration. External cable packages (DressPack) and tools can stay fitted on the robot. Fine calibration. All external cable packages (DressPack) and tools must be removed from the robot. 	
	<p>If the robot is to be calibrated with reference calibration:</p> <p>Find previous reference values for the axis or create new reference values. These values are to be used after the repair procedure is completed, for calibration of the robot.</p> <p>If no previous reference values exist, and no new reference values can be created, then reference calibration is not possible.</p>	<p>Follow the instructions given in the reference calibration routine on the FlexPendant to create reference values.</p> <p>Creating new values requires possibility to move the robot.</p> <p>Read more about reference calibration for Axis Calibration in Reference calibration routine on page 798.</p>



Continues on next page

Action	Note
<p>If the robot is to be calibrated with fine calibration: Remove all external cable packages (DressPack) and tools from the robot.</p>	

Removing the axis-4 motor sub-assembly

Use these procedures to remove the axis-4 motor sub-assembly.

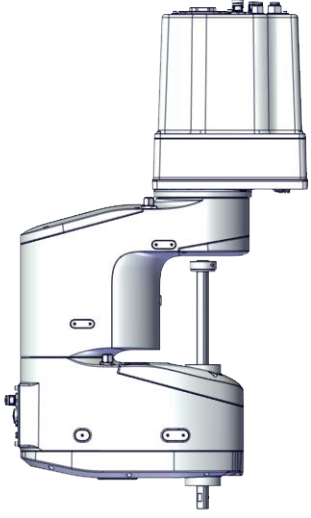
Preparations before removing the axis-4 motor sub-assembly

Action	Note
1	Decide which calibration routine to use, and take actions accordingly prior to beginning the repair procedure.
2	<p>If there is no enough space for the maintenance work, remove the robot from the wall and place it on the maintenance bracket.</p> <p> CAUTION</p> <p>Do not lay down the robot during the transportation, always keep it straight. If the robot lay down in any situation, the grease may come out from gearbox.</p>
3	<p>Jog all axes to zero position.</p> <div style="text-align: right;">  <p>xx1800002825</p> </div>
4	<p> DANGER</p> <p>Turn off all:</p> <ul style="list-style-type: none"> • electric power supply • hydraulic pressure supply • air pressure supply <p>to the robot, before entering the safeguarded space.</p>

Continues on next page



5 Repair

5.7.4 Replacing the axis-4 motor sub-assembly

Continued

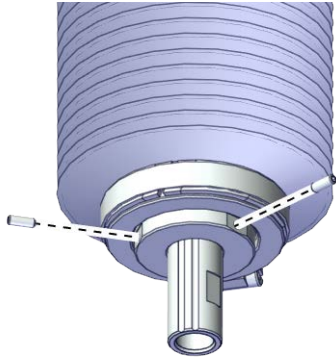
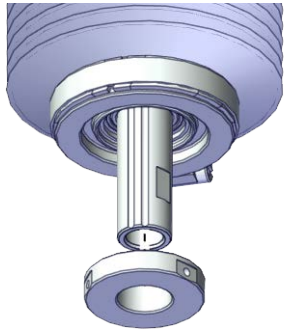

	Action	Note
5	 CAUTION For robots with protection type Clean Room Always cut the paint with a knife and grind the paint edge when disassembling parts of the robot! See Cut the paint or surface on the robot before replacing parts on page 118 .	

Removing the lower cover

	Action	Note
1	 DANGER Make sure that all supplies for electrical power, hydraulic pressure, and air pressure are turned off.	
2	 CAUTION For robots with protection type Clean Room Always cut the paint with a knife and grind the paint edge when disassembling parts of the robot! See Cut the paint or surface on the robot before replacing parts on page 118 .	
3	For robots with protection class IP54 (option 3350-540) For robots with protection type Clean Room (option 3351-1) Loose the locking screws.	 xx1900001606
4	For robots with protection class IP54 (option 3350-540) For robots with protection type Clean Room (option 3351-1) Remove the lower cover from the ball screw.	 xx1900001607

Continues on next page

Removing the cover of the outer arm





	Action	Note
1	 DANGER Make sure that all supplies for electrical power, hydraulic pressure, and air pressure are turned off.	
2	 CAUTION For robots with protection type Clean Room Always cut the paint with a knife and grind the paint edge when disassembling parts of the robot! See <i>Cut the paint or surface on the robot before replacing parts on page 118.</i>	

Continues on next page

5 Repair

5.7.4 Replacing the axis-4 motor sub-assembly

Continued

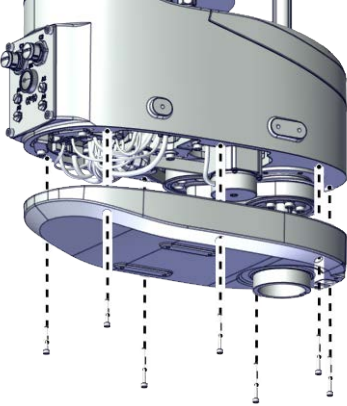
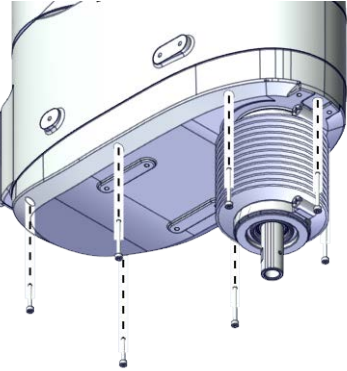
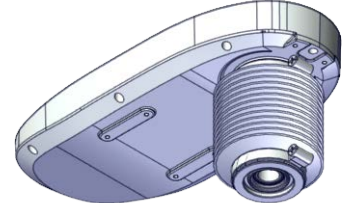
	Action	Note
3	<p>Remove the screws on the cover of the outer arm and remove the cover.</p> <p> Note</p> <p>For robots with protection class IP54 (option 3350-540) For robots with protection type Clean Room (option 3351-1) Remove the cover with bellow and housing.</p> <p> Note</p> <p>The bellow does not need to be removed separately.</p> <p> CAUTION</p> <p>There is a gasket in the cover. Be careful when removing the cover with bellow and housing.</p> <p> Tip</p> <p>Check the gasket and replace it if needed.</p>	<p>For robots with protection class IP30 (option 3350-300)</p>  <p>xx1800002836</p> <p>For robots with protection class IP54 (option 3350-540) For robots with protection type Clean Room (option 3351-1)</p>  <p>xx1900001631</p>  <p>xx1900001632</p>

Removing the bracket for the process hub



	Action	Note
1	<p> DANGER</p> <p>Make sure that all supplies for electrical power, hydraulic pressure, and air pressure are turned off.</p>	

Continues on next page

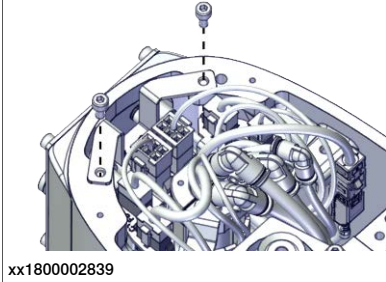
5.7.4 Replacing the axis-4 motor sub-assembly
Continued

	Action	Note
2	 CAUTION For robots with protection type Clean Room Always cut the paint with a knife and grind the paint edge when disassembling parts of the robot! See <i>Cut the paint or surface on the robot before replacing parts on page 118.</i>	
3	Remove the screws on the bracket and take it out carefully.	

Disconnecting the connectors for axis-4 motor

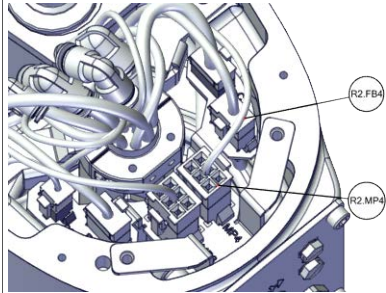
	Action	Note
1	 DANGER Make sure that all supplies for electrical power, hydraulic pressure, and air pressure are turned off.	
2	 CAUTION For robots with protection type Clean Room Always cut the paint with a knife and grind the paint edge when disassembling parts of the robot! See <i>Cut the paint or surface on the robot before replacing parts on page 118.</i>	
3	Disconnect the connectors. <ul style="list-style-type: none"> • R2.MP4 • R2.FB4 	

Continues on next page



5 Repair

5.7.4 Replacing the axis-4 motor sub-assembly

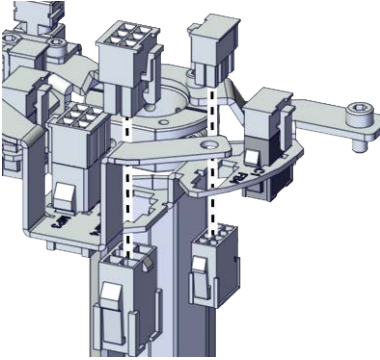
Continued

	Action	Note
4	Snap loose and remove the female head of the connectors from the bracket.	 <p>xx1900000066</p>

Removing the pulley pre-assembly with the motor

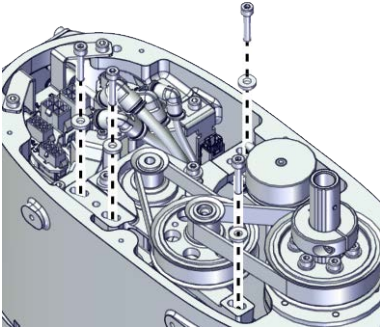

	Action	Note
1	 <p>DANGER</p> <p>Make sure that all supplies for electrical power, hydraulic pressure, and air pressure are turned off.</p>	
2	 <p>CAUTION</p> <p>For robots with protection type Clean Room Always cut the paint with a knife and grind the paint edge when disassembling parts of the robot! See Cut the paint or surface on the robot before replacing parts on page 118.</p>	
3	 <p>DANGER</p> <p>Make sure that the ball screw is supported with something. The sudden drop of the ball screw due the lost of the axis-4 motor may cause danger.</p>	
4	Remove the screws.	 <p>xx1800002888</p>

Continues on next page

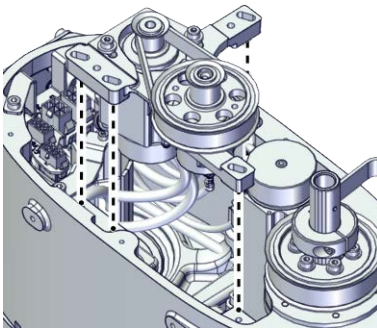
5.7.4 Replacing the axis-4 motor sub-assembly
Continued

	Action	Note
5	Remove the pulley pre-assembly and the timing belt.	 <p>xx1800002889</p>

Separating the axis-4 motor sub-assembly with the pulley pre-assembly

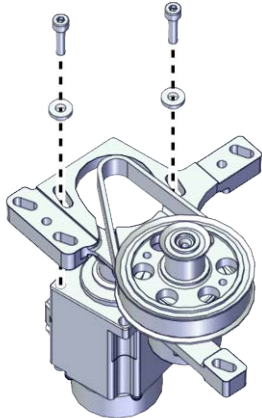
	Action	Note
1	 DANGER Make sure that all supplies for electrical power, hydraulic pressure, and air pressure are turned off.	
2	 CAUTION For robots with protection type Clean Room Always cut the paint with a knife and grind the paint edge when disassembling parts of the robot! See Cut the paint or surface on the robot before replacing parts on page 118 .	
3	Remove the screws and washers.	
4	Remove the motor and timing belt.  Tip Move the internal harness out of the way.	 <p>xx1800002890</p>

Continues on next page

5 Repair



5.7.4 Replacing the axis-4 motor sub-assembly

Continued

Refitting the axis-4 motor sub-assembly

Use these procedures to refit the axis-4 motor sub-assembly.

Refitting the axis-4 motor sub-assembly to the pulley pre-assembly

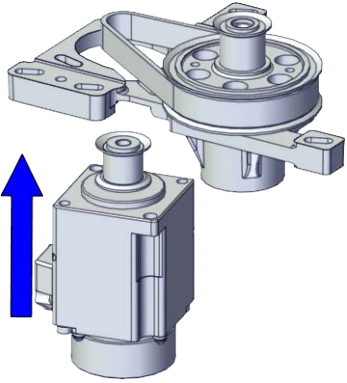
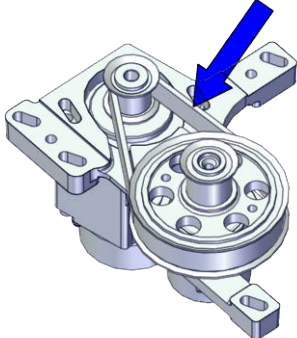
	Action	Note
1	<p>For robots with protection type Clean Room: Clean the joints that have been opened and wipe the parts free from particles with spirit on a lint free. See Cut the paint or surface on the robot before replacing parts on page 118</p> <p> Note</p> <p>After all repair work, wipe the Clean Room robot free from particles with spirit on a lint free cloth.</p>	
2	<p>Refit the motor to the pulley pre-assembly.</p> <p> Tip</p> <p>Move the internal harness out of the way.</p>	 <p>xx1800002891</p>
3	<p>Refit the timing belt to the motor. Ensure that the belt runs correctly in the grooves.</p>	<p>Timing belt: 3HAC061863-001</p>  <p>xx1800002892</p>

Continues on next page

5.7.4 Replacing the axis-4 motor sub-assembly
Continued

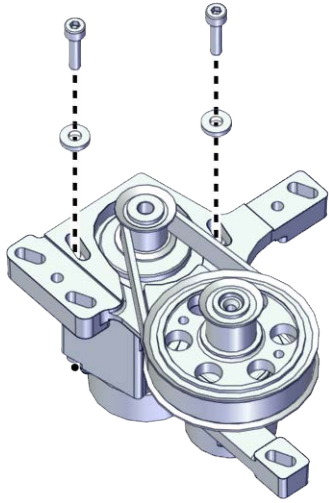
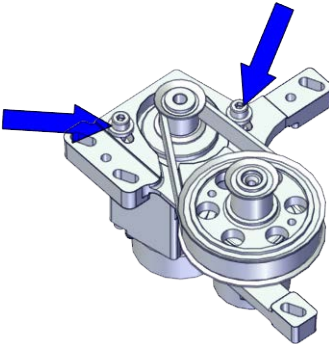
	Action	Note
4	Refit the screws and washers.	<p>Screws: Hex socket head cap screw M4x16 12.9 Lafre 2C2B/FC6.9 (2 pcs) Washers: Washer 4.3x10x2 steel (2 pcs) Tightening torque: 3 Nm ±10%</p>  <p>xx1800002893</p>
5	Use a sonic tension meter to measure the timing belt tension.	<p>Used belt: 178-217Hz New belt:210-268Hz</p>
6	If the timing belt tension does not meet the requirement, loosen the motor screws and readjust.	 <p>xx1800002894</p>

Refitting the pulley pre-assembly with the motor

	Action	Note
1	<p>For robots with protection type Clean Room: Clean the joints that have been opened and wipe the parts free from particles with spirit on a lint free. See Cut the paint or surface on the robot before replacing parts on page 118</p> <p> Note</p> <p>After all repair work, wipe the Clean Room robot free from particles with spirit on a lint free cloth.</p>	

Continues on next page

5 Repair

5.7.4 Replacing the axis-4 motor sub-assembly

Continued

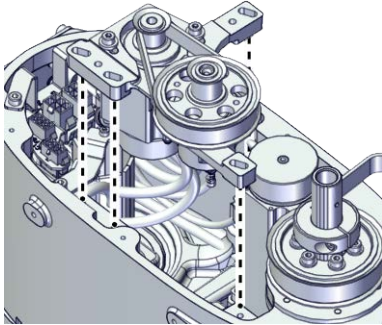
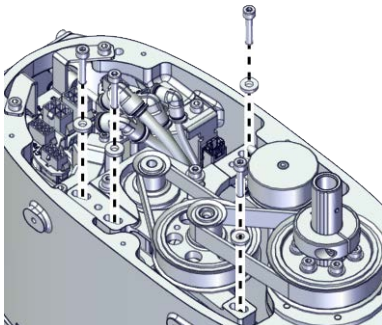

	Action	Note
2	Refit the pulley pre-assembly with the motor to the outer arm.	<p>Screws: Hex socket head cap screw M4x20 12.9 Lafre 2C2B/FC6.9 (4 pcs) Washers: Washer 4.3x10x2 steel (4 pcs) Tightening torque: 3 Nm \pm10%</p>  <p>xx1800002889</p>
3	Secure with the screws.	 <p>xx1800002888</p>

Refitting the axis-4 second timing belt

	Action	Note
1	<p>For robots with protection type Clean Room: Clean the joints that have been opened and wipe the parts free from particles with spirit on a lint free. See Cut the paint or surface on the robot before replacing parts on page 118</p> <p> Note</p> <p>After all repair work, wipe the Clean Room robot free from particles with spirit on a lint free cloth.</p>	

Continues on next page

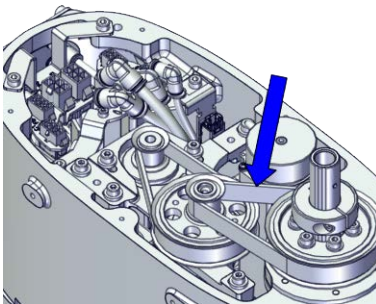
5.7.4 Replacing the axis-4 motor sub-assembly
Continued

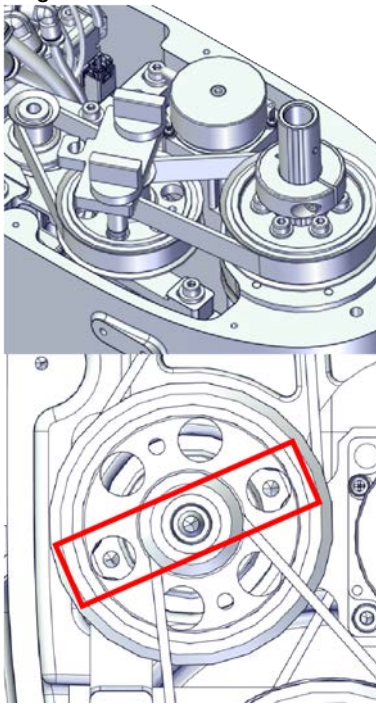

	Action	Note
2	<p>Refit the timing belt to the pulley and the motor. Ensure that the belt runs correctly in the grooves.</p>	 <p>xx1800002895</p> <p>Timing belt: 3HAC061864-001</p>
3	<p>Install the axis-4 belt tension adjustment tool to the motor.</p> <p> Note Just tighten the tool.</p>	<p>Belt tension adjustment tool set, stage two of axis 4:-</p>  <p>xx1900000096</p>

Continues on next page

5 Repair

5.7.4 Replacing the axis-4 motor sub-assembly

Continued

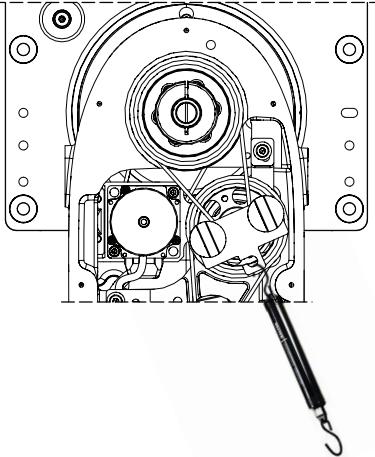
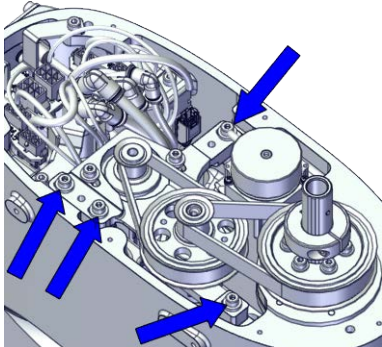



	Action	Note
4	<p>Use a handheld dynamometer hooking to the screw and pull the dynamometer to make the tension falling in the allowed force range.</p> <p> Note</p> <p>During the measurement, make sure that all interferences that may affect the force are removed. Pay attention to the force application direction.</p> <p> Tip</p> <p>If the ball screw will interfere with the handheld dynamometer, adjust the ball screw manually.</p>	<p>Used belt: 84-96N New belt:120-132N</p>  <p>xx190000097</p>
5	<p>Fasten the screws to the recommended tightening torque.</p>	<p>Tightening torque: 3 Nm \pm10%</p>  <p>xx1800003389</p>
6	<p>Use a sonic tension meter to measure the timing belt tension.</p>	<p>Used belt: 257-314Hz New belt:304-389Hz</p>
7	<p>If the timing belt tension does not meet the requirement, loosen the motor screws and readjust.</p>	
8	<p>Remove the axis-4 belt tension adjustment tool.</p>	

Reconnecting the connectors for axis-4 motor

	Action	Note
1	<p>For robots with protection type Clean Room: Clean the joints that have been opened and wipe the parts free from particles with spirit on a lint free. See Cut the paint or surface on the robot before replacing parts on page 118</p> <p> Note</p> <p>After all repair work, wipe the Clean Room robot free from particles with spirit on a lint free cloth.</p>	

Continues on next page

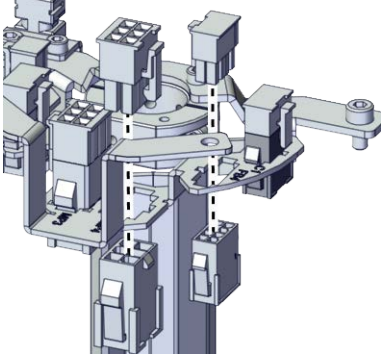
5.7.4 Replacing the axis-4 motor sub-assembly
Continued

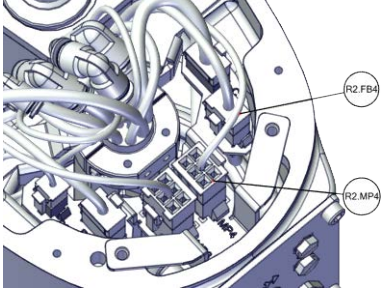
	Action	Note
2	<p>Route the cabling on the axis-4 motor behind the protected bracket to the bracket.</p> <p> CAUTION</p> <p>Correct cable routing is highly important. If the cables are routed and secured incorrectly the cables can be damaged.</p>	
	<p>Insert the female head of the connectors to the bracket accordingly.</p> <p> Tip</p> <p>The mistake proofing measure has been applied to the connectors, the connectors may be damaged if excessive force is used.</p>	 <p>xx1900000066</p>
3	<p>Reconnect the connectors.</p> <ul style="list-style-type: none"> • R2.MP4 • R2.FB4 <p> Tip</p> <p>See the number markings on the connectors for help to find the corresponding connector.</p>	 <p>xx1900000065</p>

Refitting the bracket for the process hub

	Action	Note
1	<p>For robots with protection type Clean Room: Clean the joints that have been opened and wipe the parts free from particles with spirit on a lint free. See Cut the paint or surface on the robot before replacing parts on page 118</p> <p> Note</p> <p>After all repair work, wipe the Clean Room robot free from particles with spirit on a lint free cloth.</p>	

Continues on next page

5 Repair

5.7.4 Replacing the axis-4 motor sub-assembly

Continued

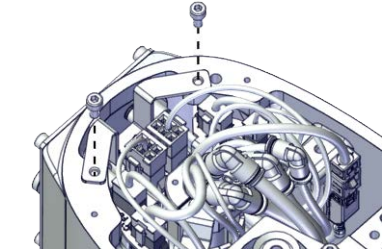

	Action	Note
2	Secure the bracket with screws.	<p>Screws: Hex socket head cap screw M4x8 12.9 Lafre 2C2B/FC6.9 (2 pcs) Tightening torque: 4 Nm \pm10%</p>  <p>xx1800002839</p>

Refitting the cover of the outer arm

	Action	Note
1	<p>For robots with protection type Clean Room: Clean the joints that have been opened and wipe the parts free from particles with spirit on a lint free. See Cut the paint or surface on the robot before replacing parts on page 118</p> <p> Note</p> <p>After all repair work, wipe the Clean Room robot free from particles with spirit on a lint free cloth.</p>	

Continues on next page

5.7.4 Replacing the axis-4 motor sub-assembly
Continued

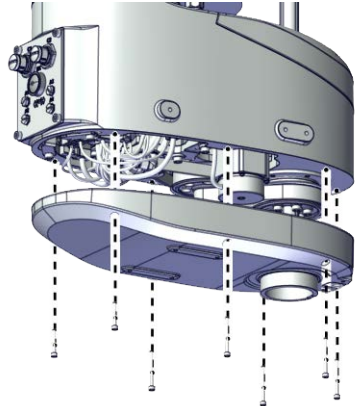
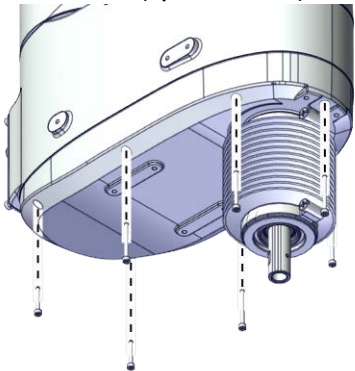
	Action	Note
2	<p>Refit the cover.</p> <p> Note</p> <p>For robots with protection class IP54 (option 3350-540)</p> <p>For robots with protection type Clean Room (option 3351-1)</p> <p>Refit the cover with bellow and housing.</p> <p>Check the gasket on the outer arm cover.</p> <p> Tip</p> <p>Replace the gasket if needed.</p>	<p>For IRB 910INV-3/0.35:</p> <p>Screw: Hex socket head cap screw M3x20 12.9 Lafre 2C2B/FC6.9 (2 pcs)</p> <p>Hex socket head cap screw M3x30 12.9 Lafre 2C2B/FC6.9 (5 pcs)</p> <p>Tightening torque: 1.2 Nm ±10%</p> <p>For IRB 910INV-6/0.55:</p> <p>Screw: Hex socket head cap screw M3x20 12.9 Lafre 2C2B/FC6.9 (2 pcs)</p> <p>Hex socket head cap screw M3x30 12.9 Lafre 2C2B/FC6.9 (7 pcs)</p> <p>Tightening torque: 1.2 Nm ±10%</p> <p>For robots with protection class IP30 (option 3350-300)</p>
3	<p>Refit the screws.</p>	 <p>xx1800002836</p> <p>For robots with protection class IP54 (option 3350-540)</p> <p>For robots with protection type Clean Room (option 3351-1)</p>  <p>xx1900001631</p>

Continues on next page

5 Repair

5.7.4 Replacing the axis-4 motor sub-assembly

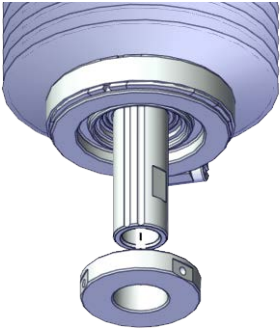
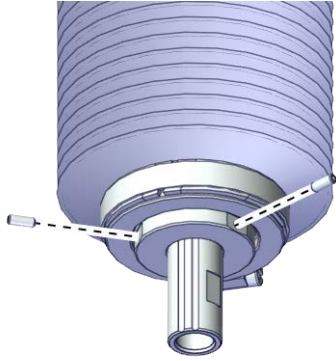

Continued

Refitting the lower cover

	Action	Note
1	<p>For robots with protection type Clean Room: Clean the joints that have been opened and wipe the parts free from particles with spirit on a lint free. See Cut the paint or surface on the robot before replacing parts on page 118</p> <p> Note</p> <p>After all repair work, wipe the Clean Room robot free from particles with spirit on a lint free cloth.</p>	
2	<p>For robots with protection class IP54 (option 3350-540)</p> <p>For robots with protection type Clean Room (option 3351-1)</p> <p>Refit the lower cover to the ball screw.</p>	 <p>xx1900001607</p>
3	<p>For robots with protection class IP54 (option 3350-540)</p> <p>For robots with protection type Clean Room (option 3351-1)</p> <p>Refit the locking screws.</p>	<p>Screws: Hexagon socket set screws with flat point, ISO 4026 stainless steel M3x8 (2 pcs)</p> <p>Tightening torque: 0.6 Nm \pm10%</p>  <p>xx1900001606</p>

Continues on next page

Concluding procedure

	Action	Note
1	<p>For robots with protection type Clean Room: Seal and paint the joints that have been opened. See Cut the paint or surface on the robot before replacing parts on page 118</p> <p> Note</p> <p>After all repair work, wipe the Clean Room robot free from particles with spirit on a lint free cloth.</p>	
2	Recalibrate the robot.	Calibration is detailed in section Calibration on page 771 .
3	<p> DANGER</p> <p>Make sure all safety requirements are met when performing the first test run. See Test run after installation, maintenance, or repair on page 56.</p>	

5 Repair

5.8.1 Replacing the axis-1 gear unit sub-assembly

5.8 Gearboxes

5.8.1 Replacing the axis-1 gear unit sub-assembly

Location of the axis-1 gear unit sub-assembly

The axis-1 gear unit sub-assembly is located as shown in the figure.

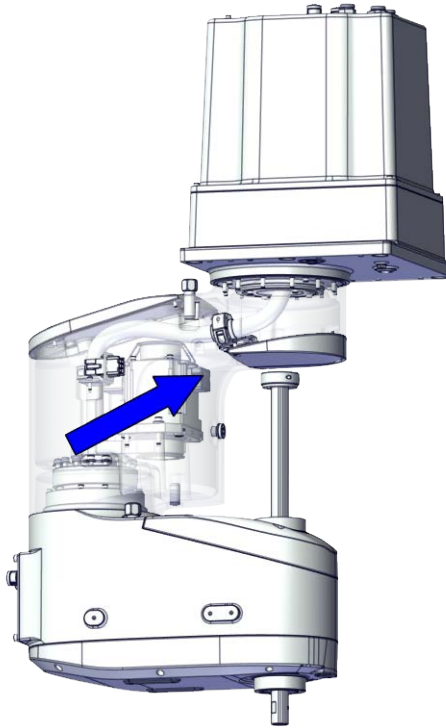

xx1800002896

Required spare parts



Note

The spare part numbers that are listed in the table can be out of date. See the latest spare parts of the IRB 910INV via myABB Business Portal, www.abb.com/myABB.

Spare part	Article number	Note
Axis-1 gear unit sub-assembly	3HAC073046-001	Used for IRB 910INV-3/0.35
Axis-1 gear unit sub-assembly	3HAC073062-001	Used for IRB 910INV-6/0.55

Required tools and equipment

Equipment	Article number	Note
Standard toolkit	-	Content is defined in section Standard toolkit on page 840 .

Continues on next page

5.8.1 Replacing the axis-1 gear unit sub-assembly

Continued

Equipment	Article number	Note
Calibration tool box, Axis Calibration	3HAC074119-001	Delivered as a set of calibration tools. Required if Axis Calibration is the valid calibration method for the robot. ⁱ
Belt tension adjustment tool set, axis 1&2	-	Included in the special toolkit 3HAC073070-001. Used to adjust the tension of axis-1&2 timing belts. Special tool for L2
Sonic tension meter	-	Used for measuring the timing belt tension.
Handheld dynamometer	-	Used for measuring the timing belt tension.

ⁱ The robot is calibrated by either manual calibration or Axis Calibration at ABB factory before delivery. Always use the same calibration method as used at the factory.
Information about valid calibration method is found on the calibration label or in the calibration menu on the FlexPendant.
If no data is found related to standard calibration, manual calibration is used as default.

Required consumables

Consumable	Article number	Note
Cable straps	-	
Grease	3HAC029132-001	FM 222 Used to lubricate the cable harness.
Sealing compound	3HAC026759-002	Sikaflex 521 FC For robots with protection type Clean Room.

Deciding calibration routine

Decide which calibration routine to be used, based on the information in the table. Depending on which routine is chosen, action might be required prior to beginning the repair work of the robot, see the table.

	Action	Note
1	Decide which calibration routine to use for calibrating the robot. <ul style="list-style-type: none"> Reference calibration. External cable packages (DressPack) and tools can stay fitted on the robot. Fine calibration. All external cable packages (DressPack) and tools must be removed from the robot. 	

Continues on next page

5 Repair

5.8.1 Replacing the axis-1 gear unit sub-assembly

Continued

Action	Note
<p>If the robot is to be calibrated with reference calibration: Find previous reference values for the axis or create new reference values. These values are to be used after the repair procedure is completed, for calibration of the robot.</p> <p>If no previous reference values exist, and no new reference values can be created, then reference calibration is not possible.</p>	<p>Follow the instructions given in the reference calibration routine on the FlexPendant to create reference values.</p> <p>Creating new values requires possibility to move the robot.</p> <p>Read more about reference calibration for Axis Calibration in Reference calibration routine on page 798.</p>
<p>If the robot is to be calibrated with fine calibration: Remove all external cable packages (DressPack) and tools from the robot.</p>	

Removing the axis-1 gear unit sub-assembly

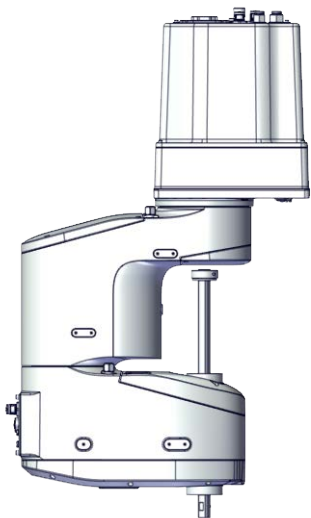

Use these procedures to remove the axis-1 gear unit sub-assembly.

Preparations before removing the axis-1 gear unit sub-assembly



	Action	Note
1	Decide which calibration routine to use, and take actions accordingly prior to beginning the repair procedure.	
2	<p>If there is no enough space for the maintenance work, remove the robot from the wall and place it on the maintenance bracket.</p> <p> CAUTION</p> <p>Do not lay down the robot during the transportation, always keep it straight.</p> <p>If the robot lay down in any situation, the grease may come out from gearbox.</p>	
3	Jog all axes to zero position.	 <p>xx1800002825</p>

Continues on next page

5.8.1 Replacing the axis-1 gear unit sub-assembly
Continued

	Action	Note
4	Move the ball screw to the lowest position.	 <p>xx1800002898</p>
5	 DANGER Turn off all: <ul style="list-style-type: none"> • electric power supply • hydraulic pressure supply • air pressure supply to the robot, before entering the safeguarded space.	
6	 CAUTION For robots with protection type Clean Room Always cut the paint with a knife and grind the paint edge when disassembling parts of the robot! See Cut the paint or surface on the robot before replacing parts on page 118 .	

Removing the base cover

	Action	Note
1	 DANGER Make sure that all supplies for electrical power, hydraulic pressure, and air pressure are turned off.	
2	 CAUTION For robots with protection type Clean Room Always cut the paint with a knife and grind the paint edge when disassembling parts of the robot! See Cut the paint or surface on the robot before replacing parts on page 118 .	

Continues on next page

5 Repair

5.8.1 Replacing the axis-1 gear unit sub-assembly

Continued

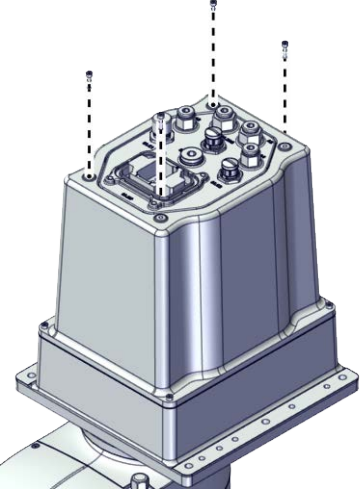
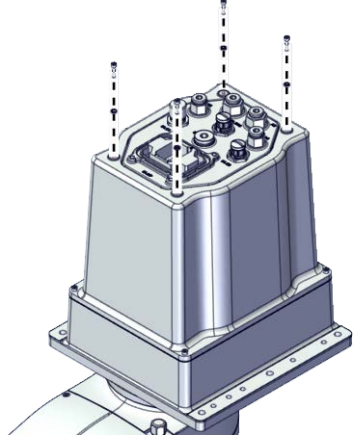

	Action	Note
3	<p>Remove the screws on the base cover to the base harness.</p> <p> Note</p> <p>For robots with protection class IP54 (option 3350-540)</p> <p>For robots with protection type Clean Room (option 3351-1)</p> <p>Remove the extra sealing washers on the base cover to the base harness.</p>	<p>For robots with protection class IP30 (option 3350-300)</p>  <p>xx1800002826</p> <p>For robots with protection class IP54 (option 3350-540)</p> <p>For robots with protection type Clean Room (option 3351-1)</p>  <p>xx1900001634</p>

Continues on next page

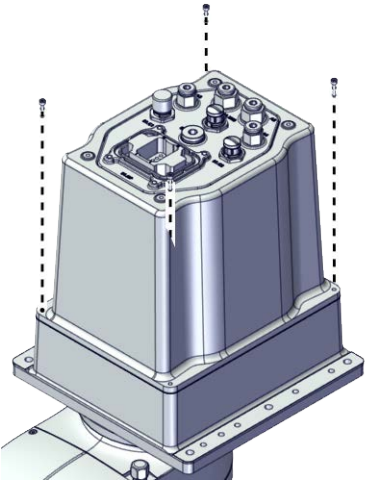
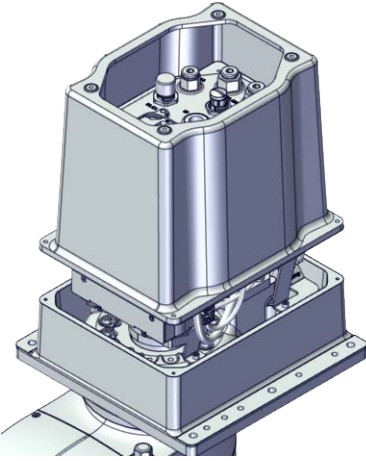
5.8.1 Replacing the axis-1 gear unit sub-assembly
Continued

	Action	Note
4	Remove the screws on the base cover to the base.	 <p>xx1800002827</p>
5	Take the base cover out.	 <p>xx1800002828</p>

Disconnecting the connectors on the base harness



	Action	Note
1	 <p>DANGER</p> <p>Make sure that all supplies for electrical power, hydraulic pressure, and air pressure are turned off.</p>	
2	 <p>CAUTION</p> <p>For robots with protection type Clean Room Always cut the paint with a knife and grind the paint edge when disassembling parts of the robot! See <i>Cut the paint or surface on the robot before replacing parts on page 118.</i></p>	

Continues on next page

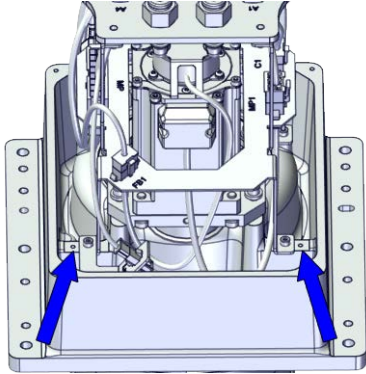

5 Repair

5.8.1 Replacing the axis-1 gear unit sub-assembly

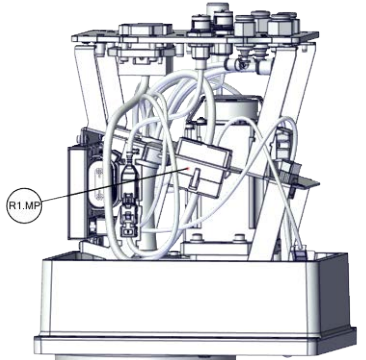
Continued





	Action	Note
3	Remove the three grounding cables from the bracket by unscrew the screws.	 <p>xx1900000062</p>
4	Disconnect the connector. <ul style="list-style-type: none"> R1.MP  Tip Take photos of the connector and cable position before disconnecting them, to have as a reference when reconnecting.	 <p>xx1800002829</p>

Disconnecting the air hoses, C1 cabling and C2 cabling (if equipped)

	Action	Note
1	 DANGER Make sure that all supplies for electrical power, hydraulic pressure, and air pressure are turned off.	
2	 CAUTION For robots with protection type Clean Room Always cut the paint with a knife and grind the paint edge when disassembling parts of the robot! See Cut the paint or surface on the robot before replacing parts on page 118.	

Continues on next page

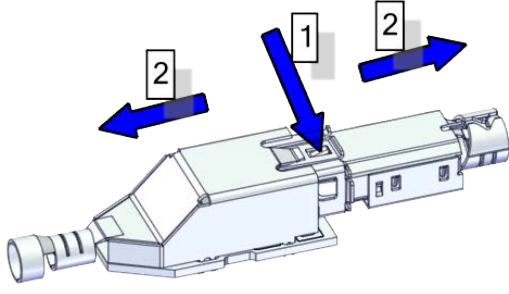
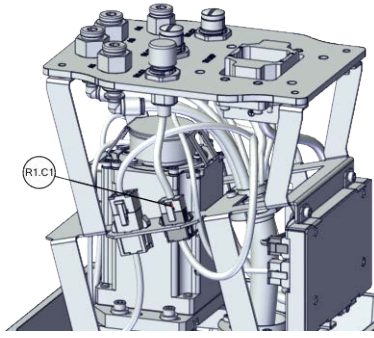
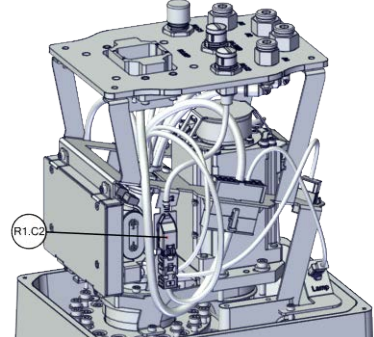
5.8.1 Replacing the axis-1 gear unit sub-assembly
Continued

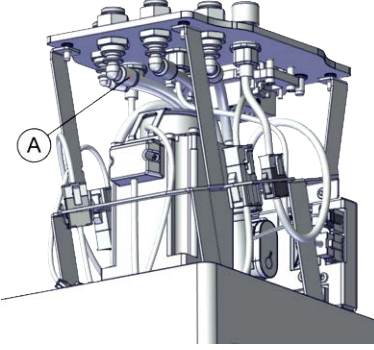
	Action	Note		
3	<p>Cut the cable straps and disconnect the connectors.</p> <ul style="list-style-type: none"> • R1.C1 • R1.C2 <p> Tip</p> <p>Take photos of the connector and cable position before disconnecting them, to have as a reference when reconnecting.</p> <p> Tip</p> <p>The connector clip has to be pressed (1) and pushed forward (2) to separate the R1.C2 (for C2 cabling).</p>  <p>xx1800002943</p>	 <p>xx1800002831</p>  <p>xx1800002832</p>		
4	<p>Disconnect the air hoses from the L-shaped connectors.</p> <p> Note</p> <p>Make sure that the air hoses are not bent or broken when you disconnect them.</p>	 <p>xx1800002830</p> <table border="1" data-bbox="1061 1612 1436 1657"> <tr> <td data-bbox="1061 1612 1117 1657">A</td> <td data-bbox="1117 1612 1436 1657">Air hoses</td> </tr> </table>	A	Air hoses
A	Air hoses			

Disconnecting the SMB cabling



	Action	Note
1	<p> DANGER</p> <p>Make sure that all supplies for electrical power, hydraulic pressure, and air pressure are turned off.</p>	

Continues on next page



5 Repair

5.8.1 Replacing the axis-1 gear unit sub-assembly

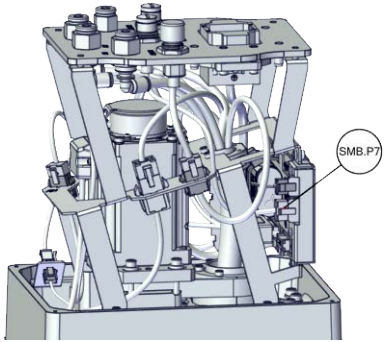
Continued

	Action	Note
2	 ELECTROSTATIC DISCHARGE (ESD) The unit is sensitive to ESD. Before handling the unit read the safety information in section The unit is sensitive to ESD on page 45 .	
3	 CAUTION For robots with protection type Clean Room Always cut the paint with a knife and grind the paint edge when disassembling parts of the robot! See Cut the paint or surface on the robot before replacing parts on page 118 .	
4	Disconnect the connectors. <ul style="list-style-type: none"> • SMB.P7 • SMB.J1 (Only when the internal harness)  Tip Take photos of the connector and cable position before disconnecting them, to have as a reference when reconnecting.	 <p>xx1800002833</p>



Removing the base harness

	Action	Note
1	 DANGER Make sure that all supplies for electrical power, hydraulic pressure, and air pressure are turned off.	
2	 CAUTION For robots with protection type Clean Room Always cut the paint with a knife and grind the paint edge when disassembling parts of the robot! See Cut the paint or surface on the robot before replacing parts on page 118 .	

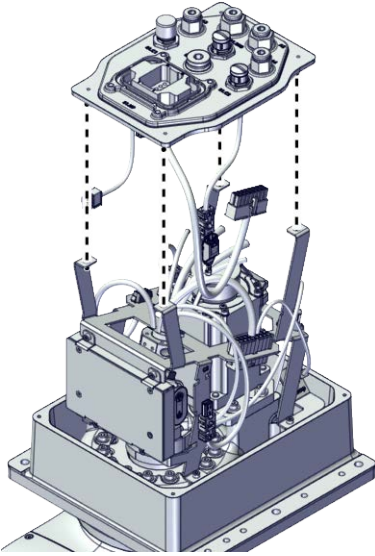
Continues on next page

	Action	Note
3	Remove the base harness from the bracket.	 <p>xx1800002834</p>

Removing the bracket

	Action	Note
1	 <p>DANGER</p> <p>Make sure that all supplies for electrical power, hydraulic pressure, and air pressure are turned off.</p>	
2	 <p>CAUTION</p> <p>For robots with protection type Clean Room Always cut the paint with a knife and grind the paint edge when disassembling parts of the robot! See <i>Cut the paint or surface on the robot before replacing parts on page 118.</i></p>	

Continues on next page

5 Repair

5.8.1 Replacing the axis-1 gear unit sub-assembly

Continued

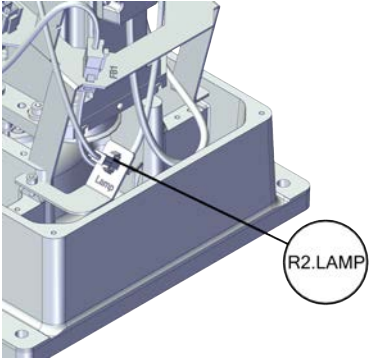
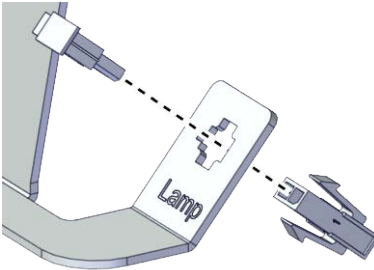
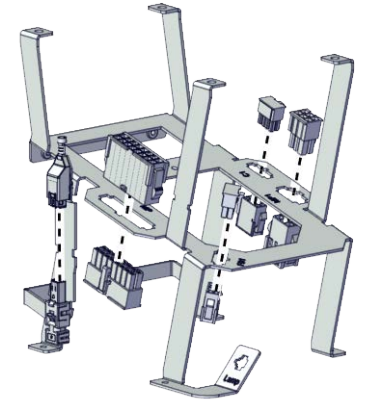
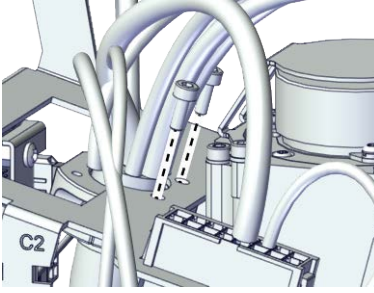

	Action	Note
3	Disconnect the lamp connector on the bracket.	 <p>xx1800002867</p>  <p>xx1900000079</p>
4	Snap loose and remove the female head of the connectors from the bracket.	 <p>xx1900000081</p>
5	Release the cable ferrule from the bracket.	 <p>xx1900000080</p>

Continues on next page

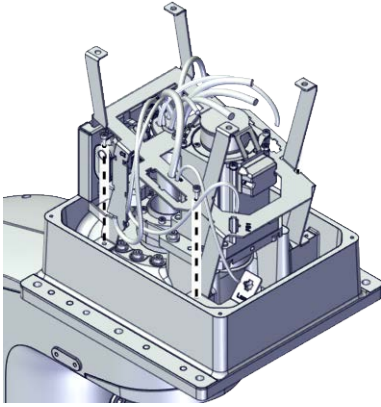
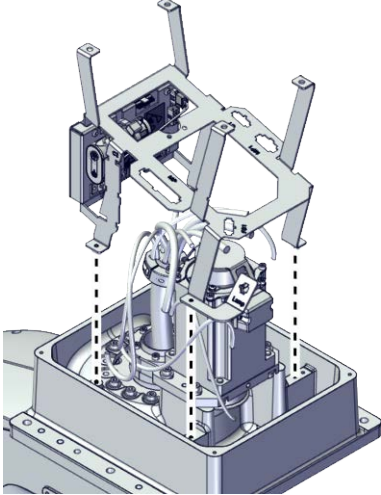
5.8.1 Replacing the axis-1 gear unit sub-assembly
Continued

	Action	Note
6	Remove the screws on the bracket.	 <p>xx1800002868</p>
7	Remove the bracket.	 <p>xx1800002869</p>

Removing the axis-1 motor sub-assembly

	Action	Note
1	 DANGER Make sure that all supplies for electrical power, hydraulic pressure, and air pressure are turned off.	
2	 CAUTION For robots with protection type Clean Room Always cut the paint with a knife and grind the paint edge when disassembling parts of the robot! See Cut the paint or surface on the robot before replacing parts on page 118.	

Continues on next page



5 Repair

5.8.1 Replacing the axis-1 gear unit sub-assembly

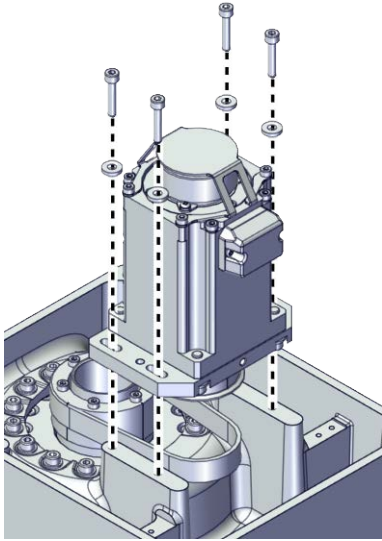
Continued

	Action	Note
3	Remove the screws and washers.	 <p>xx1800002870</p>
4	Remove the motor and the timing belt.	

Removing the base

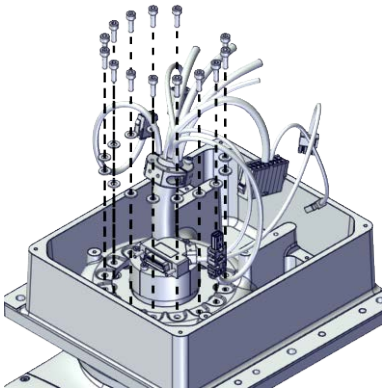

	Action	Note
1	 DANGER Make sure that all supplies for electrical power, hydraulic pressure, and air pressure are turned off.	
2	 CAUTION For robots with protection type Clean Room Always cut the paint with a knife and grind the paint edge when disassembling parts of the robot! See Cut the paint or surface on the robot before replacing parts on page 118 .	
3	Remove the screws and washers.	 <p>xx1800002851</p>

Continues on next page

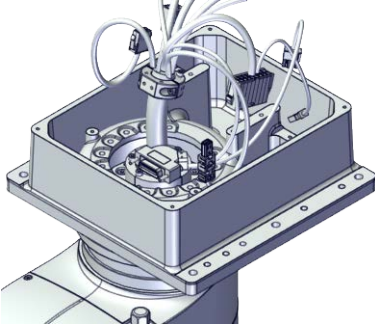
5.8.1 Replacing the axis-1 gear unit sub-assembly
Continued

	Action	Note
4	Remove the base.	 <p data-bbox="1061 645 1173 667">xx1800002852</p>

Removing the cover of the inner arm

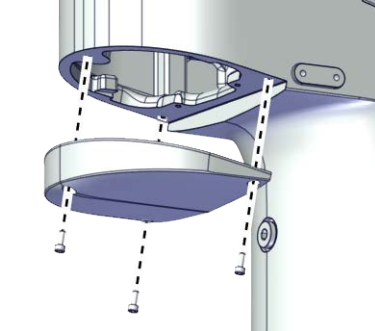
	Action	Note
1	 <p data-bbox="603 840 710 869">DANGER</p> <p data-bbox="510 900 1045 981">Make sure that all supplies for electrical power, hydraulic pressure, and air pressure are turned off.</p>	
2	 <p data-bbox="603 1041 715 1070">CAUTION</p> <p data-bbox="510 1102 1045 1243">For robots with protection type Clean Room Always cut the paint with a knife and grind the paint edge when disassembling parts of the robot! See Cut the paint or surface on the robot before replacing parts on page 118.</p>	
3	Remove the screws.	 <p data-bbox="1061 1617 1173 1639">xx1800002899</p>
4	Remove the cover.	

Removing the cable ferrule in the base

	Action	Note
1	 <p data-bbox="603 1812 710 1841">DANGER</p> <p data-bbox="510 1872 1045 1953">Make sure that all supplies for electrical power, hydraulic pressure, and air pressure are turned off.</p>	

Continues on next page



5 Repair

5.8.1 Replacing the axis-1 gear unit sub-assembly

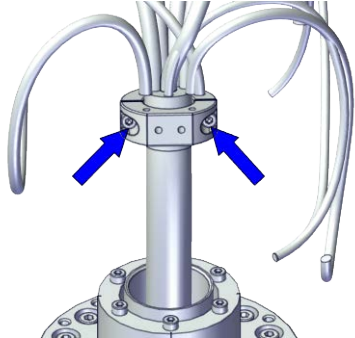
Continued



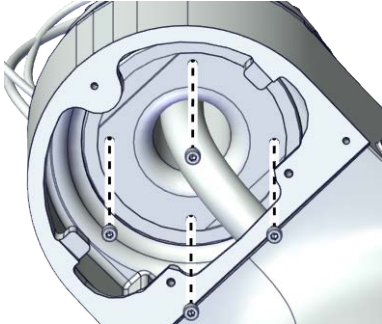

	Action	Note
2	 CAUTION For robots with protection type Clean Room Always cut the paint with a knife and grind the paint edge when disassembling parts of the robot! See Cut the paint or surface on the robot before replacing parts on page 118 .	
3	Remove the screws.	 xx1800002900
4	Remove the cable ferrule on the cable.	

Removing the axis-1 gear unit sub-assembly

	Action	Note
1	 DANGER Make sure that all supplies for electrical power, hydraulic pressure, and air pressure are turned off.	
2	 CAUTION For robots with protection type Clean Room Always cut the paint with a knife and grind the paint edge when disassembling parts of the robot! See Cut the paint or surface on the robot before replacing parts on page 118 .	
3	Remove the screws on the sleeve inside the inner arm.  Tip If the sleeve is not broken, separate the sleeve from the axis-1 gear unit sub-assembly. As the biggest connector on the internal harness upper side cannot pass the sleeve, so it's easier to separate the sleeve when removing the axis-1 gear unit sub-assembly.	 xx1800003378

Continues on next page

5.8.1 Replacing the axis-1 gear unit sub-assembly
Continued

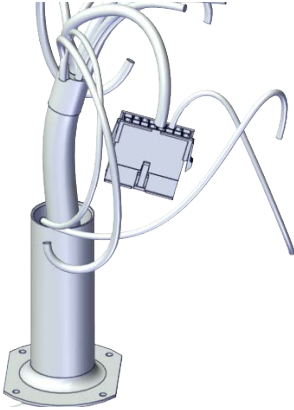
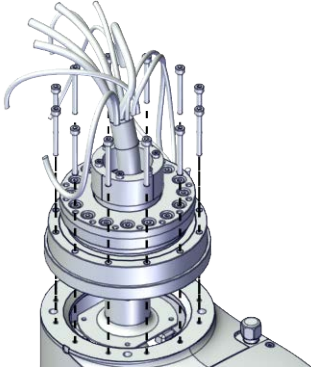
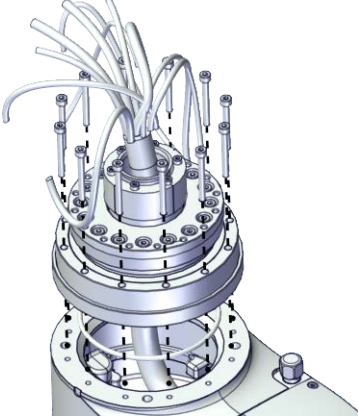
	Action	Note
4	Remove the screws.	
5	<p>Remove the gear unit through the cable slightly.</p> <p> Note</p> <p>For robots with protection class IP54 (option 3350-540)</p> <p>For robots with protection type Clean Room (option 3351-1)</p> <p>Remove the gear unit and the O-ring through the cable slightly.</p> <p> Tip</p> <p>Check the O-ring and replace it if needed.</p> <p> Tip</p> <p>Wrap the connectors with the masking tape.</p> <p> Tip</p> <p>Just remove the axis-1 gear unit sub-assembly without the sleeve.</p> <p>The MP connector cannot pass the sleeve.</p>  <p>xx190000145</p>	<p>For robots with protection class IP30 (option 3350-300)</p>  <p>xx1800003379</p> <p>For robots with protection class IP54 (option 3350-540)</p> <p>For robots with protection type Clean Room (option 3351-1)</p>  <p>xx1900001652</p>

Continues on next page

5 Repair







5.8.1 Replacing the axis-1 gear unit sub-assembly

Continued

Refitting the axis-1 gear unit sub-assembly

Use these procedures to refit the axis-1 gear unit sub-assembly.

Refitting the axis-1 gear unit sub-assembly

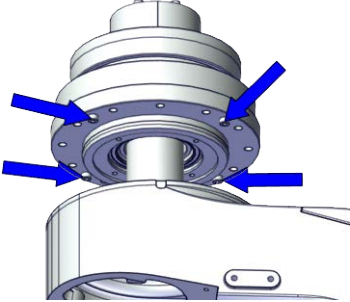
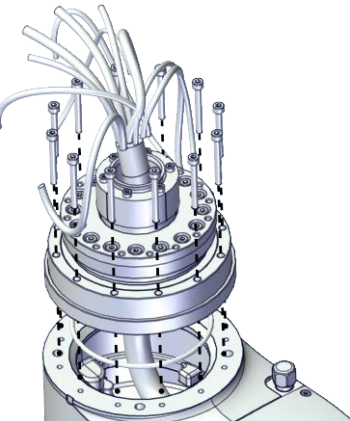
	Action	Note
1	<p>For robots with protection type Clean Room: Clean the joints that have been opened and wipe the parts free from particles with spirit on a lint free. See Cut the paint or surface on the robot before replacing parts on page 118</p> <p> Note</p> <p>After all repair work, wipe the Clean Room robot free from particles with spirit on a lint free cloth.</p>	
2	<p> CAUTION</p> <p>Whenever parting/mating motor and gearbox, the gears may be damaged if excessive force is used.</p>	
3	<p>Refit the gear unit according to the location pin through the cable.</p> <p> Note</p> <p>For robots with protection class IP54 (option 3350-540) For robots with protection type Clean Room (option 3351-1) Refit the gear unit and the O-ring according to the location pin through the cable.</p> <p> Tip</p> <p>Check the O-ring and replace it if needed.</p> <p> Tip</p> <p>When the gear unit is in the right position, you can hear a clear "Click".</p> <p> Tip</p> <p>Wrap the connectors with the masking tape.</p>	<p>For robots with protection class IP30 (option 3350-300)</p>  <p>xx1800003380</p> <p>For robots with protection class IP54 (option 3350-540) For robots with protection type Clean Room (option 3351-1)</p>  <p>xx1900001652</p>

Continues on next page

5.8.1 Replacing the axis-1 gear unit sub-assembly
Continued

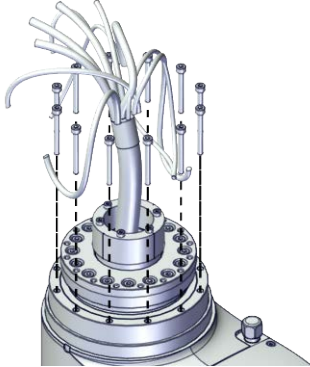
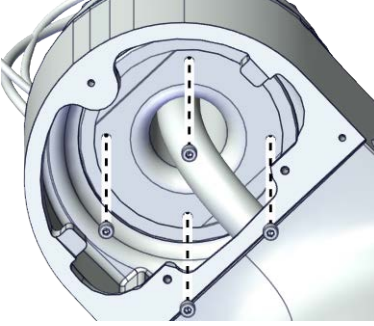
	Action	Note
4	Refit the screws.	<p>Screws: Hex socket head cap screw M4x35 12.9 Lafre 2C2B/FC6.9 (12 pcs) Tightening torque: 0.5 Nm-1 Nm-2 Nm-4.5 Nm ±10%</p>  <p>xx1800003381</p>
5	Refit the screws on the sleeve inside the inner arm.	<p>Screws: Hex socket head cap screw M3x5 12.9 Lafre 2C2B/FC6.9 (4 pcs) Tightening torque: 1.8 Nm ±10%</p>  <p>xx1800003378</p>

Refitting the cable ferrule in the base



	Action	Note
1	<p>For robots with protection type Clean Room: Clean the joints that have been opened and wipe the parts free from particles with spirit on a lint free. See Cut the paint or surface on the robot before replacing parts on page 118</p> <p> Note</p> <p>After all repair work, wipe the Clean Room robot free from particles with spirit on a lint free cloth.</p>	

Continues on next page

5 Repair

5.8.1 Replacing the axis-1 gear unit sub-assembly

Continued

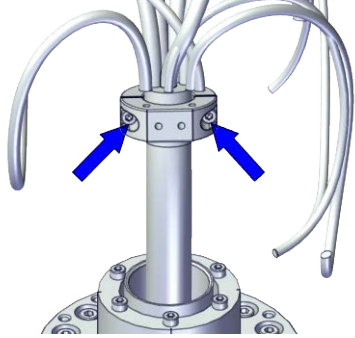
	Action	Note
2	<p>Refit the cable ferrule to the cable and secure it with the screw.</p> <p> Tip</p> <p>The cable ferrule should be refitted at the position where the tape is wrapped.</p> <p> Tip</p> <p>Align all the cable ferrules so that the cable is in a natural bending position to avoid twisting.</p>	<p>Screws: Hex socket head cap screw M3x5 12.9 Lafre 2C2B/FC6.9 (2 pcs)</p> <p>Tightening torque: 1.5 Nm \pm10%</p>  <p>xx1800002900</p>

Refitting the base

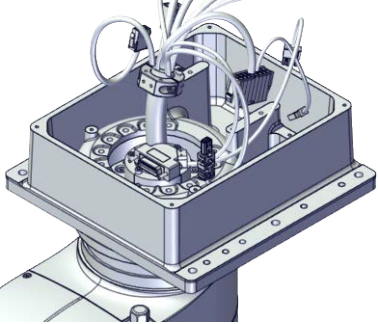
	Action	Note
1	<p>For robots with protection type Clean Room: Clean the joints that have been opened and wipe the parts free from particles with spirit on a lint free. See Cut the paint or surface on the robot before replacing parts on page 118</p> <p> Note</p> <p>After all repair work, wipe the Clean Room robot free from particles with spirit on a lint free cloth.</p>	
2	<p>Refit the base to the axis-1 gearbox as the illustration.</p>	 <p>xx1800002852</p>

Continues on next page

5.8.1 Replacing the axis-1 gear unit sub-assembly
Continued

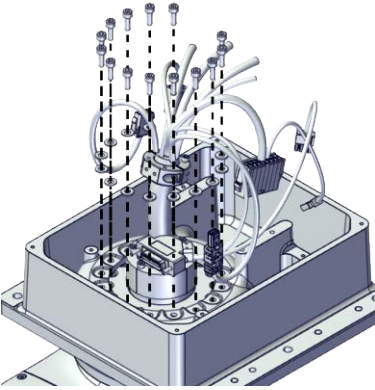
	Action	Note
3	Refit the screws.	<p>Screws: Hex socket head cap screw M4x12 12.9 Lafre 2C2B/FC6.9 (14 pcs) Tightening torque: 0.5 Nm-1 Nm-2 Nm-4 Nm $\pm 10\%$</p> 

Refitting the axis-1 motor sub-assembly



	Action	Note
1	<p>For robots with protection type Clean Room: Clean the joints that have been opened and wipe the parts free from particles with spirit on a lint free. See Cut the paint or surface on the robot before replacing parts on page 118</p> <p> Note</p> <p>After all repair work, wipe the Clean Room robot free from particles with spirit on a lint free cloth.</p>	

Continues on next page

5 Repair

5.8.1 Replacing the axis-1 gear unit sub-assembly

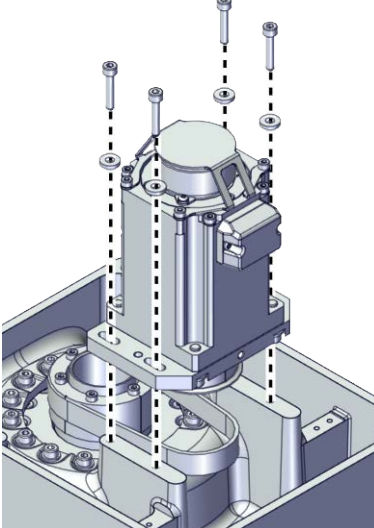
Continued

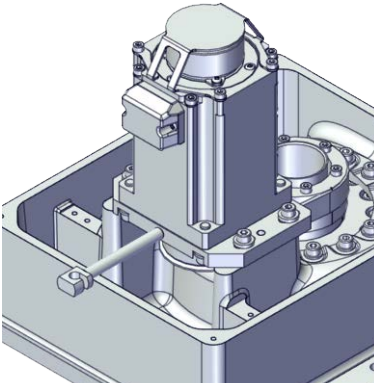
	Action	Note
2	Refit the timing belt to the pulley.	Screws: Hex socket head cap screw M4x20 12.9 Lafre 2C2B/FC6.9 (4 pcs) Washers: Washer 4.3x10x2 steel (4 pcs) Tightening torque: 3 Nm \pm 10%
3	Refit the motor.	
4	Refit the timing belt to the motor. Ensure that the belt runs correctly in the grooves.	
5	Refit the screws and washers without fully tightened.	 <p data-bbox="1029 1041 1141 1064">xx1800002870</p> <p data-bbox="1029 1086 1220 1142">Timing belt: 3HAC061864-001</p>
6	Install the axis1&2 belt tension adjustment tool to the motor.  Note Just tighten the tool.	Belt tension adjustment tool set, axis 1&2:-  <p data-bbox="1029 1624 1141 1646">xx1900000093</p>

Continues on next page

5.8.1 Replacing the axis-1 gear unit sub-assembly

Continued

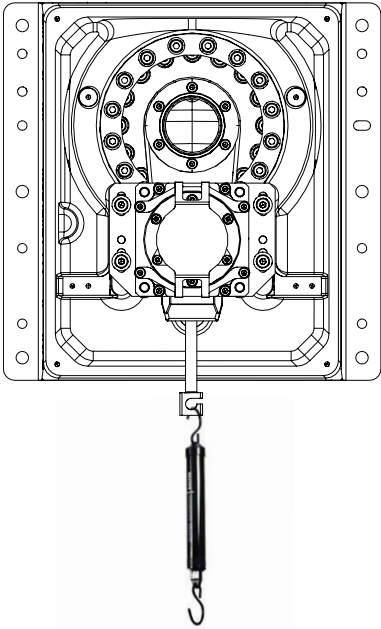
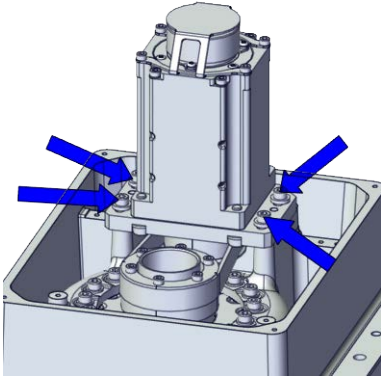
	Action	Note
7	<p>Use a handheld dynamometer hooking to the special tool and pull the dynamometer to make the tension falling in the allowed force range.</p> <p> Note</p> <p>During the measurement, make sure that all interferences that may affect the force are removed. Pay attention to the force application direction.</p>	<p>Used belt: 70-80N New belt:100-110N</p>  <p>xx1900000094</p>
8	<p>Fasten the screws to the recommended tightening torque.</p>	<p>Tightening torque: 3 Nm ±10%</p>  <p>xx1800002871</p>
9	<p>Use a sonic tension meter to measure the timing belt tension.</p>	<p>Used belt: 250-305Hz New belt:296-378Hz</p>
10	<p>If the timing belt tension does not meet the requirement, loosen the motor screws and readjust.</p>	



Continues on next page

5 Repair

5.8.1 Replacing the axis-1 gear unit sub-assembly

Continued

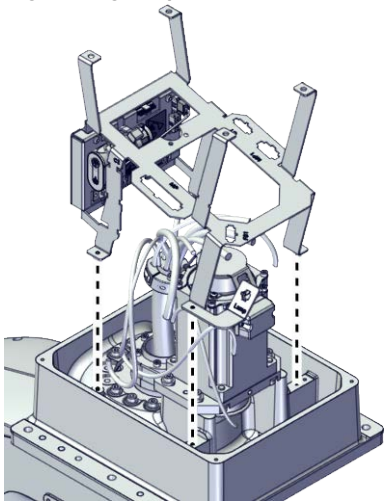
Refitting the bracket

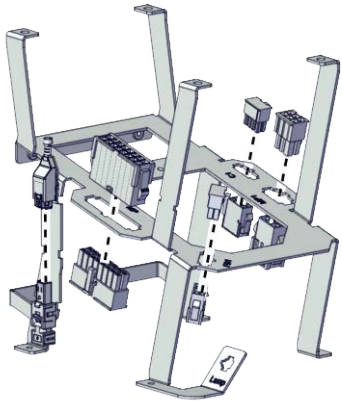
	Action	Note
1	<p>For robots with protection type Clean Room: Clean the joints that have been opened and wipe the parts free from particles with spirit on a lint free. See Cut the paint or surface on the robot before replacing parts on page 118</p> <p> Note</p> <p>After all repair work, wipe the Clean Room robot free from particles with spirit on a lint free cloth.</p>	
2	<p>Refit the bracket and secure with the screws.</p>	<p>Screws: Hex socket head cap screw M3x8 12.9 Lafre 2C2B/FC6.9 (4 pcs) Tightening torque: 1.5 Nm \pm10%</p>  <p>xx1800002869</p>
3	<p>Insert the female head of the connectors to the bracket accordingly.</p> <p> Tip</p> <p>The mistake proofing measure has been applied to the connectors, the connectors may be damaged if excessive force is used.</p>	 <p>xx1900000081</p>

Continues on next page

5.8.1 Replacing the axis-1 gear unit sub-assembly
Continued

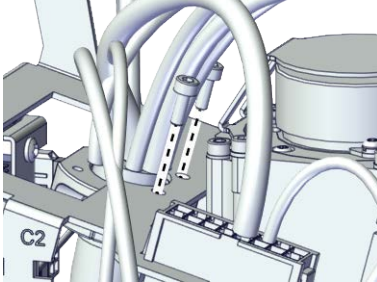
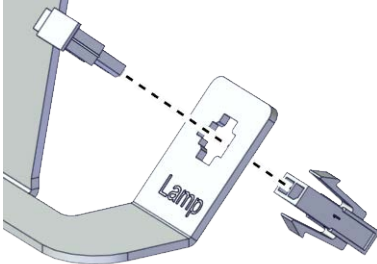
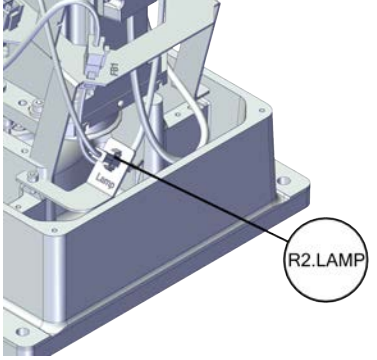
	Action	Note
4	Secure the cable ferrule to the bracket with the screws.	<p>Screws: Hex socket head cap screw M3x5 12.9 Lafre 2C2B/FC6.9 (2 pcs) Tightening torque: 1.5 Nm ±10%</p>  <p>xx190000080</p>
5	Reconnect the lamp connector on the bracket.	 <p>xx190000079</p>  <p>xx1800002867</p>

Refitting the base harness

	Action	Note
1	<p>For robots with protection type Clean Room: Clean the joints that have been opened and wipe the parts free from particles with spirit on a lint free. See Cut the paint or surface on the robot before replacing parts on page 118</p> <p> Note</p> <p>After all repair work, wipe the Clean Room robot free from particles with spirit on a lint free cloth.</p>	

Continues on next page



5 Repair

5.8.1 Replacing the axis-1 gear unit sub-assembly

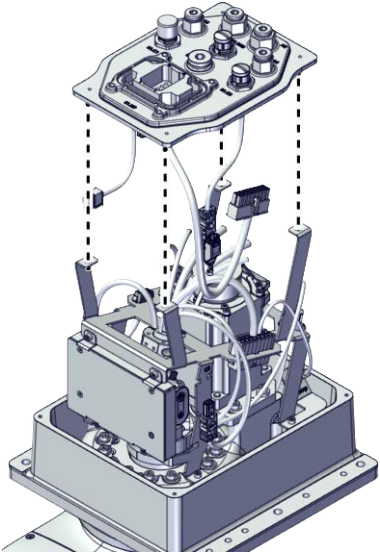
Continued

	Action	Note
2	Refit the base harness to the bracket.	 <p>xx1800002834</p>

Reconnecting the SMB cabling

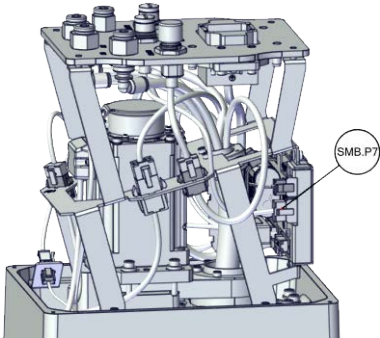

	Action	Note
1	 <p>ELECTROSTATIC DISCHARGE (ESD)</p> <p>The unit is sensitive to ESD. Before handling the unit read the safety information in section The unit is sensitive to ESD on page 45.</p>	
2	<p>For robots with protection type Clean Room: Clean the joints that have been opened and wipe the parts free from particles with spirit on a lint free. See Cut the paint or surface on the robot before replacing parts on page 118</p> <p> Note</p> <p>After all repair work, wipe the Clean Room robot free from particles with spirit on a lint free cloth.</p>	
3	<p>Reconnect the connectors.</p> <ul style="list-style-type: none"> • SMB.P7 • SMB.J1 <p> Tip</p> <p>See the number markings on the connectors for help to find the corresponding connector.</p>	 <p>xx1800002833</p>

Continues on next page

5.8.1 Replacing the axis-1 gear unit sub-assembly
Continued

	Action	Note
4	<p>Route and secure the cabling with cable straps if needed.</p> <p> CAUTION</p> <p>Correct cable routing is highly important. If the cables are routed and secured incorrectly the cables can be damaged.</p>	

Reconnecting the air hoses, C1 cabling and C2 cabling (if equipped)

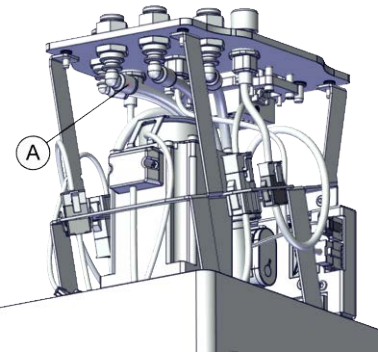

	Action	Note		
1	<p>For robots with protection type Clean Room: Clean the joints that have been opened and wipe the parts free from particles with spirit on a lint free. See Cut the paint or surface on the robot before replacing parts on page 118</p> <p> Note</p> <p>After all repair work, wipe the Clean Room robot free from particles with spirit on a lint free cloth.</p>			
2	<p>Reconnect the air hoses in a cross pattern to the L-shaped connectors on the base harness.</p> <p> Tip</p> <p>See the number markings on the air hoses for help to find the corresponding air hoses. The air hoses with the same number connect to the same L-shaped connector.</p> <p> Note</p> <p>Make sure that the air hoses are not bent or broken when you disconnect them.</p>	 <p>xx1800002830</p> <table border="1" data-bbox="1062 1424 1441 1469"> <tr> <td data-bbox="1062 1424 1118 1469">A</td> <td data-bbox="1118 1424 1441 1469">Air hoses</td> </tr> </table>	A	Air hoses
A	Air hoses			

Continues on next page

5 Repair

5.8.1 Replacing the axis-1 gear unit sub-assembly

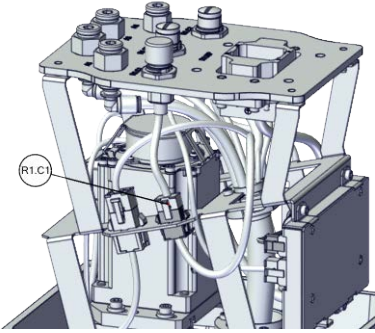
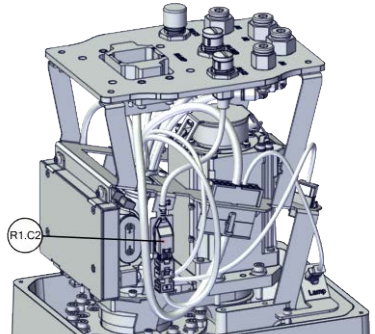
Continued



	Action	Note
3	<p>Reconnect the connectors.</p> <ul style="list-style-type: none"> • R1.C1 • R1.C2 <p> Tip</p> <p>See the number markings on the connectors for help to find the corresponding connector.</p>	 <p>xx1800002831</p>  <p>xx1800002832</p>
4	<p>Route and secure the cabling with cable straps if needed.</p> <p> CAUTION</p> <p>Correct cable routing is highly important. If the cables are routed and secured incorrectly the cables can be damaged.</p>	

Reconnecting the connectors on the base harness

	Action	Note
1	<p>For robots with protection type Clean Room: Clean the joints that have been opened and wipe the parts free from particles with spirit on a lint free. See Cut the paint or surface on the robot before replacing parts on page 118</p> <p> Note</p> <p>After all repair work, wipe the Clean Room robot free from particles with spirit on a lint free cloth.</p>	

Continues on next page

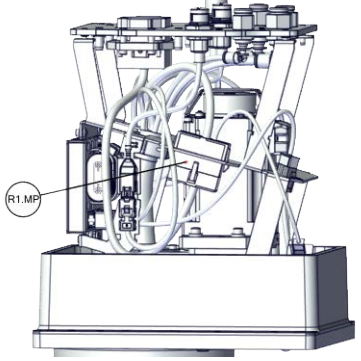
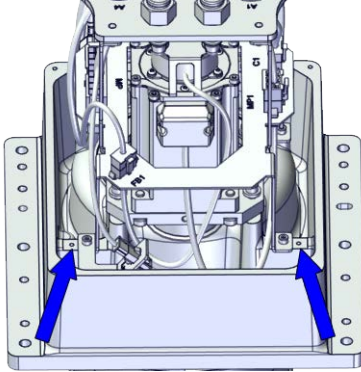
5.8.1 Replacing the axis-1 gear unit sub-assembly
Continued

	Action	Note
2	<p>Reconnect the connector.</p> <ul style="list-style-type: none"> R1.MP  Tip See the number markings on the connectors for help to find the corresponding connector.	 <p>xx1800002829</p>
3	<p>Secure the three grounding cables to the bracket with the screw.</p>	<p>Screws: Hex socket head cap screw M3x5 12.9 Lafre 2C2B/FC6.9 (2 pcs) Tightening torque: 1.5 Nm ±10%</p>  <p>xx1900000062</p>
4	<p>Route and secure the cabling with cable straps if needed.</p>  CAUTION Correct cable routing is highly important. If the cables are routed and secured incorrectly the cables can be damaged.	

Refitting the base cover



	Action	Note
1	<p>For robots with protection type Clean Room: Clean the joints that have been opened and wipe the parts free from particles with spirit on a lint free. See Cut the paint or surface on the robot before replacing parts on page 118</p>  Note After all repair work, wipe the Clean Room robot free from particles with spirit on a lint free cloth.	

Continues on next page

5 Repair

5.8.1 Replacing the axis-1 gear unit sub-assembly

Continued

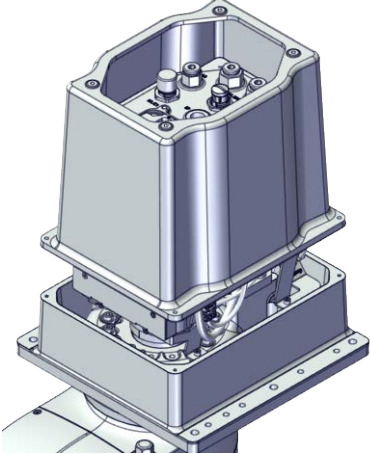
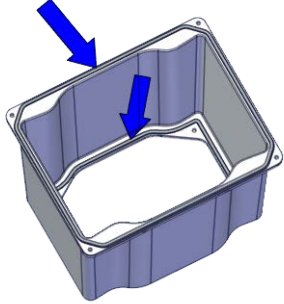
	Action	Note
2	Apply grease to the internal harness, cover all moving area of the harness.	
3	Apply grease to the covers that have contacting area with the harness.	
4	<p>Refit the base cover.</p> <p> Note</p> <p>For robots with protection class IP54 (option 3350-540)</p> <p>For robots with protection type Clean Room (option 3351-1)</p> <p>Check the gasket for the base and the gasket for the base cover before refitting the base cover.</p> <p> Tip</p> <p>Replace the gasket if needed.</p>	 <p>xx1800002828</p> <p>For robots with protection class IP54 (option 3350-540)</p> <p>For robots with protection type Clean Room (option 3351-1)</p>  <p>xx1900001635</p>

Continues on next page

5.8.1 Replacing the axis-1 gear unit sub-assembly

Continued

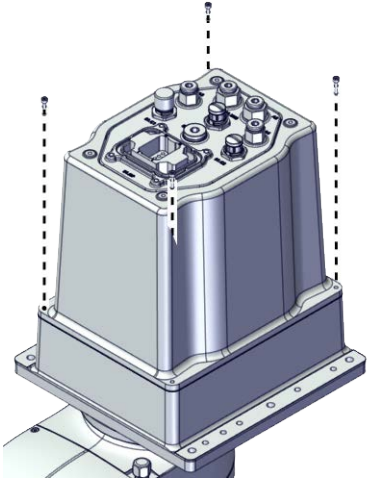
	Action	Note
5	Secure the base cover to the base with the screws.	<p>Screws: Hex socket head cap screw M3x12 12.9 Lafre 2C2B/FC6.9 (4 pcs) Tightening torque: 1.2 Nm \pm10%</p>  <p>xx1800002827</p>

Continues on next page

5 Repair

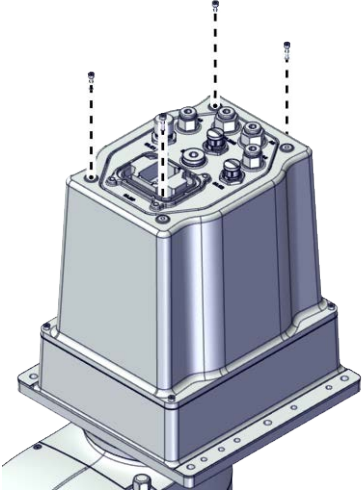
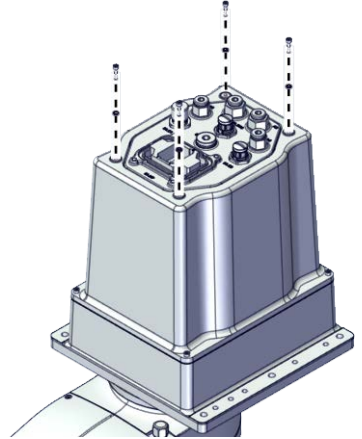

5.8.1 Replacing the axis-1 gear unit sub-assembly

Continued

	Action	Note
6	<p>Secure the base harness to the base cover with the screws.</p> <p> Note</p> <p>For robots with protection class IP54 (option 3350-540)</p> <p>For robots with protection type Clean Room (option 3351-1)</p> <p>Refit the extra sealing washers on the base cover to the base harness.</p>	<p>For robots with protection class IP30 (option 3350-300)</p> <p>Screws: Hex socket head cap screw M3x12 12.9 Lafre 2C2B/FC6.9 (4 pcs)</p> <p>Tightening torque: 1.2 Nm \pm10%</p>  <p>xx1800002826</p> <p>For robots with protection class IP54 (option 3350-540)</p> <p>For robots with protection type Clean Room (option 3351-1)</p> <p>Screws: Hex socket head cap screw M3x12 12.9 Lafre 2C2B/FC6.9 (4 pcs)</p> <p>Washers: Sealing washer M3 (4 pcs)</p> <p>Tightening torque: 1.2 Nm \pm10%</p>  <p>xx1900001634</p>

Continues on next page

Refitting the cover of the inner arm

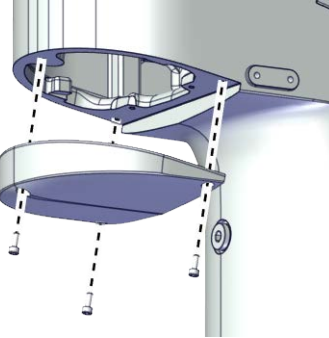
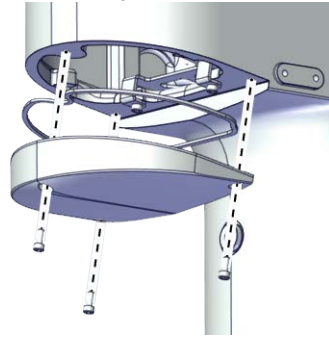
	Action	Note
1	<p>For robots with protection type Clean Room: Clean the joints that have been opened and wipe the parts free from particles with spirit on a lint free. See Cut the paint or surface on the robot before replacing parts on page 118</p> <p> Note</p> <p>After all repair work, wipe the Clean Room robot free from particles with spirit on a lint free cloth.</p>	
2	<p>Refit the cover.</p> <p> Note</p> <p>For robots with protection class IP54 (option 3350-540)</p> <p>For robots with protection type Clean Room (option 3351-1)</p> <p>Check the gasket for the cover before refitting the base cover.</p> <p> Tip</p> <p>Replace the gasket if needed.</p>	<p>Screw: Hex socket head cap screw M3x8 12.9 Lafre 2C2B/FC6.9 (3 pcs)</p> <p>Tightening torque: 1.2 Nm ±10%</p> <p>For robots with protection class IP30 (option 3350-300)</p> 
3	<p>Refit the screws.</p>	<p>xx1800002899</p> <p>For robots with protection class IP54 (option 3350-540)</p> <p>For robots with protection type Clean Room (option 3351-1)</p>  <p>xx1900001636</p>



Continues on next page

5 Repair

5.8.1 Replacing the axis-1 gear unit sub-assembly

Continued

Concluding procedure

	Action	Note
1	<p>For robots with protection type Clean Room: Seal and paint the joints that have been opened. See Cut the paint or surface on the robot before replacing parts on page 118</p> <p> Note</p> <p>After all repair work, wipe the Clean Room robot free from particles with spirit on a lint free cloth.</p>	
2	Recalibrate the robot.	Calibration is detailed in section Calibration on page 771 .
3	<p> DANGER</p> <p>Make sure all safety requirements are met when performing the first test run. See Test run after installation, maintenance, or repair on page 56.</p>	

5.8.2 Replacing the axis-2 gear unit sub-assembly

Location of the axis-2 gear unit sub-assembly

The axis-2 gear unit sub-assembly is located as shown in the figure.

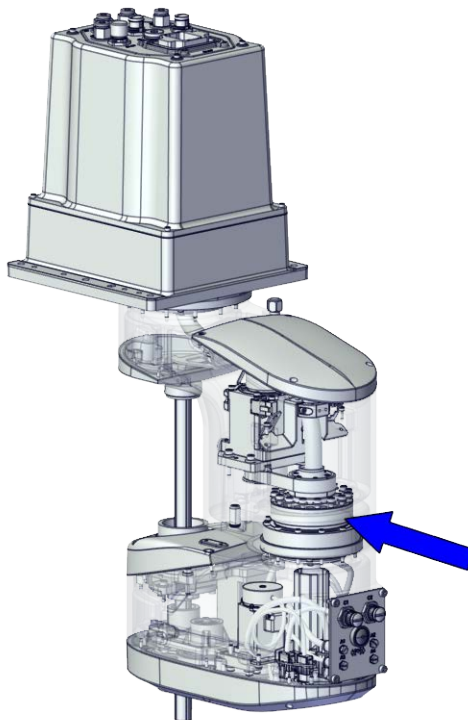

xx1800002897

Required spare parts



Note

The spare part numbers that are listed in the table can be out of date. See the latest spare parts of the IRB 910INV via myABB Business Portal, www.abb.com/myABB.

Spare part	Article number	Note
Axis-2 gear unit sub-assembly	3HAC073054-001	

Required tools and equipment

Equipment	Article number	Note
Standard toolkit	-	Content is defined in section Standard toolkit on page 840 .
Calibration tool box, Axis Calibration	3HAC074119-001	Delivered as a set of calibration tools. Required if Axis Calibration is the valid calibration method for the robot. ¹

Continues on next page

5 Repair

5.8.2 Replacing the axis-2 gear unit sub-assembly

Continued

Equipment	Article number	Note
Belt tension adjustment tool set, axis 1&2	-	Included in the special toolkit 3HAC073070-001. Used to adjust the tension of axis-1&2 timing belts. Special tool for L2
Sonic tension meter	-	Used for measuring the timing belt tension.
Handheld dynamometer	-	Used for measuring the timing belt tension.

- i The robot is calibrated by either manual calibration or Axis Calibration at ABB factory before delivery. Always use the same calibration method as used at the factory.
Information about valid calibration method is found on the calibration label or in the calibration menu on the FlexPendant.
If no data is found related to standard calibration, manual calibration is used as default.

Required consumables

Consumable	Article number	Note
Cable straps	-	
Grease	3HAC029132-001	FM 222 Used to lubricate the cable harness.

Deciding calibration routine

Decide which calibration routine to be used, based on the information in the table. Depending on which routine is chosen, action might be required prior to beginning the repair work of the robot, see the table.



	Action	Note
1	Decide which calibration routine to use for calibrating the robot. <ul style="list-style-type: none"> Reference calibration. External cable packages (DressPack) and tools can stay fitted on the robot. Fine calibration. All external cable packages (DressPack) and tools must be removed from the robot. 	
	If the robot is to be calibrated with reference calibration: Find previous reference values for the axis or create new reference values. These values are to be used after the repair procedure is completed, for calibration of the robot. If no previous reference values exist, and no new reference values can be created, then reference calibration is not possible.	Follow the instructions given in the reference calibration routine on the FlexPendant to create reference values. Creating new values requires possibility to move the robot. Read more about reference calibration for Axis Calibration in Reference calibration routine on page 798 .
	If the robot is to be calibrated with fine calibration: Remove all external cable packages (DressPack) and tools from the robot.	

Continues on next page

Removing the axis-2 gear unit sub-assembly

Use these procedures to remove the axis-2 gear unit sub-assembly.

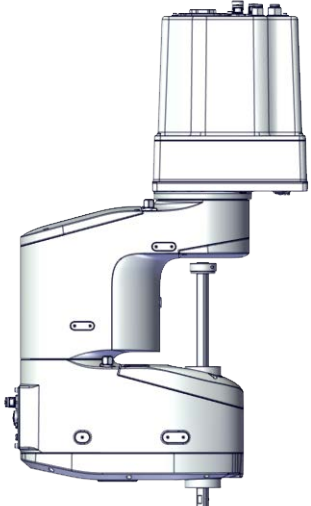
Preparations before removing the axis-2 gear unit sub-assembly

	Action	Note
1	Decide which calibration routine to use, and take actions accordingly prior to beginning the repair procedure.	
2	<p>If there is no enough space for the maintenance work, remove the robot from the wall and place it on the maintenance bracket.</p> <p> CAUTION</p> <p>Do not lay down the robot during the transportation, always keep it straight. If the robot lay down in any situation, the grease may come out from gearbox.</p>	
3	Jog all axes to zero position.	 <p>xx1800002825</p>
4	<p> DANGER</p> <p>Turn off all:</p> <ul style="list-style-type: none"> • electric power supply • hydraulic pressure supply • air pressure supply <p>to the robot, before entering the safeguarded space.</p>	
5	<p> CAUTION</p> <p>For robots with protection type Clean Room Always cut the paint with a knife and grind the paint edge when disassembling parts of the robot! See <i>Cut the paint or surface on the robot before replacing parts on page 118.</i></p>	



Continues on next page

5 Repair

5.8.2 Replacing the axis-2 gear unit sub-assembly

Continued

Removing the lower cover

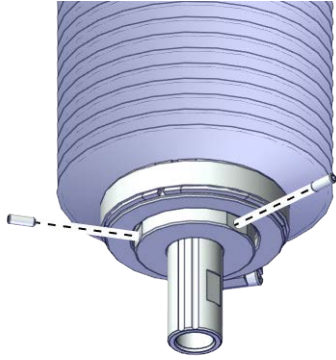
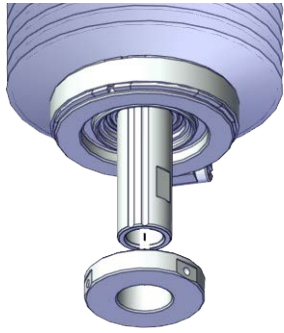



	Action	Note
1	 DANGER Make sure that all supplies for electrical power, hydraulic pressure, and air pressure are turned off.	
2	 CAUTION For robots with protection type Clean Room Always cut the paint with a knife and grind the paint edge when disassembling parts of the robot! See Cut the paint or surface on the robot before replacing parts on page 118 .	
3	For robots with protection class IP54 (option 3350-540) For robots with protection type Clean Room (option 3351-1) Loose the locking screws.	 <small>xx1900001606</small>
4	For robots with protection class IP54 (option 3350-540) For robots with protection type Clean Room (option 3351-1) Remove the lower cover from the ball screw.	 <small>xx1900001607</small>

Removing the cover of the outer arm

	Action	Note
1	 DANGER Make sure that all supplies for electrical power, hydraulic pressure, and air pressure are turned off.	

Continues on next page

5.8.2 Replacing the axis-2 gear unit sub-assembly
Continued

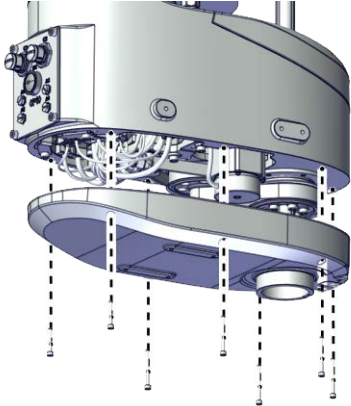
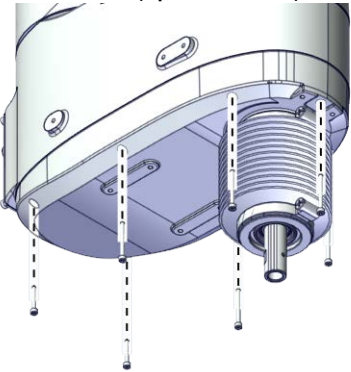
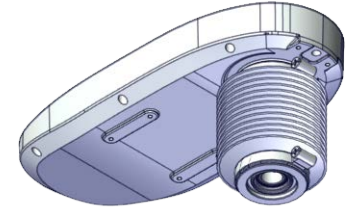
	Action	Note
2	<p> CAUTION</p> <p>For robots with protection type Clean Room Always cut the paint with a knife and grind the paint edge when disassembling parts of the robot! See <i>Cut the paint or surface on the robot before replacing parts on page 118.</i></p>	
3	<p>Remove the screws on the cover of the outer arm and remove the cover.</p> <p> Note</p> <p>For robots with protection class IP54 (option 3350-540) For robots with protection type Clean Room (option 3351-1) Remove the cover with bellow and housing.</p> <p> Note</p> <p>The bellow does not need to be removed separately.</p> <p> CAUTION</p> <p>There is a gasket in the cover. Be careful when removing the cover with bellow and housing.</p> <p> Tip</p> <p>Check the gasket and replace it if needed.</p>	<p>For robots with protection class IP30 (option 3350-300)</p>  <p>xx1800002836</p> <p>For robots with protection class IP54 (option 3350-540) For robots with protection type Clean Room (option 3351-1)</p>  <p>xx1900001631</p>  <p>xx1900001632</p>



Continues on next page

5 Repair



5.8.2 Replacing the axis-2 gear unit sub-assembly

Continued

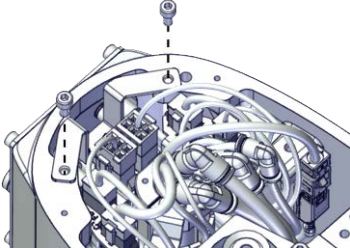
Removing the bracket for the process hub

	Action	Note
1	 DANGER Make sure that all supplies for electrical power, hydraulic pressure, and air pressure are turned off.	
2	 CAUTION For robots with protection type Clean Room Always cut the paint with a knife and grind the paint edge when disassembling parts of the robot! See Cut the paint or surface on the robot before replacing parts on page 118 .	
3	Remove the screws on the bracket and take it out carefully.	 xx1800002839

Disconnecting the connectors for axis-3 motor

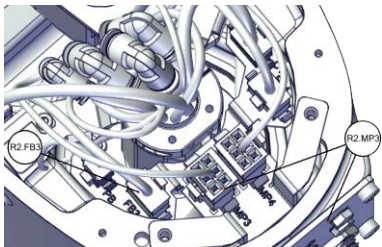

	Action	Note
1	 DANGER Make sure that all supplies for electrical power, hydraulic pressure, and air pressure are turned off.	
2	 CAUTION For robots with protection type Clean Room Always cut the paint with a knife and grind the paint edge when disassembling parts of the robot! See Cut the paint or surface on the robot before replacing parts on page 118 .	
3	Disconnect the connectors. <ul style="list-style-type: none"> • R2.MP3 • R2.FB3 	 xx1900000063

Continues on next page

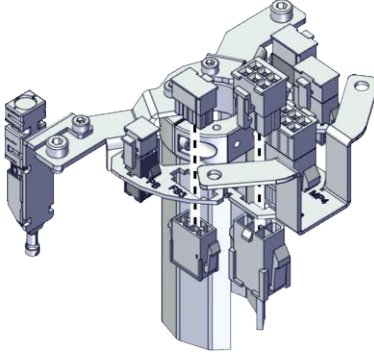
5.8.2 Replacing the axis-2 gear unit sub-assembly
Continued

	Action	Note
4	Snap loose and remove the female head of the connectors from the bracket.	 <p>xx1900000064</p>

Disconnecting the connectors for axis-4 motor

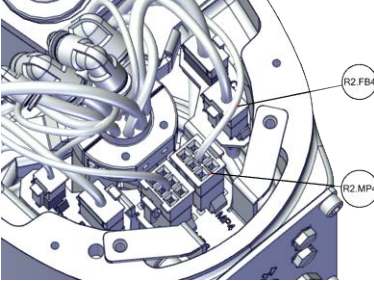
	Action	Note
1	 DANGER Make sure that all supplies for electrical power, hydraulic pressure, and air pressure are turned off.	
2	 CAUTION For robots with protection type Clean Room Always cut the paint with a knife and grind the paint edge when disassembling parts of the robot! See Cut the paint or surface on the robot before replacing parts on page 118.	
3	Disconnect the connectors. <ul style="list-style-type: none"> • R2.MP4 • R2.FB4 	 <p>xx1900000065</p>

Continues on next page



5 Repair

5.8.2 Replacing the axis-2 gear unit sub-assembly

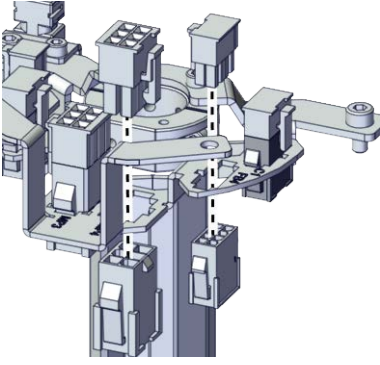
Continued

	Action	Note
4	Snap loose and remove the female head of the connectors from the bracket.	 <p>xx1900000066</p>

Disconnecting the connector for PB

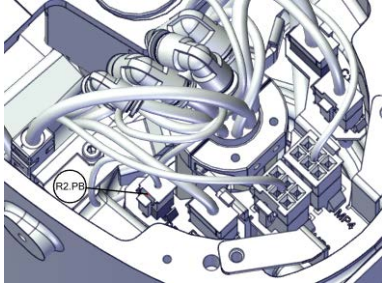

	Action	Note
1	 DANGER Make sure that all supplies for electrical power, hydraulic pressure, and air pressure are turned off.	
2	 CAUTION For robots with protection type Clean Room Always cut the paint with a knife and grind the paint edge when disassembling parts of the robot! See Cut the paint or surface on the robot before replacing parts on page 118 .	
3	Disconnect the connector. <ul style="list-style-type: none"> R2.PB 	 <p>xx1900000068</p>

Continues on next page

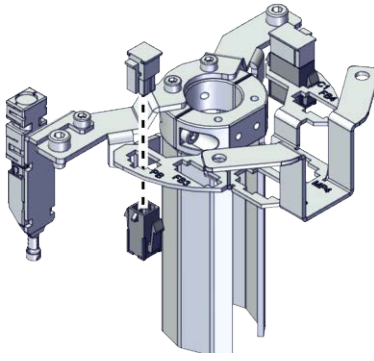
5.8.2 Replacing the axis-2 gear unit sub-assembly
Continued

	Action	Note
4	Snap loose and remove the female head of the connector from the bracket.	 <p>xx190000069</p>

Disconnecting the air hoses, C1 cabling and C2 cabling (if equipped)

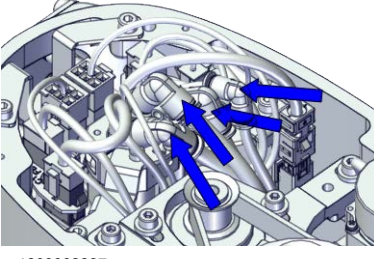



	Action	Note
1	 DANGER Make sure that all supplies for electrical power, hydraulic pressure, and air pressure are turned off.	
2	 CAUTION For robots with protection type Clean Room Always cut the paint with a knife and grind the paint edge when disassembling parts of the robot! See Cut the paint or surface on the robot before replacing parts on page 118 .	
3	Disconnect the air hoses from the L-shaped connectors.	 <p>xx1800002837</p>

Continues on next page

5 Repair

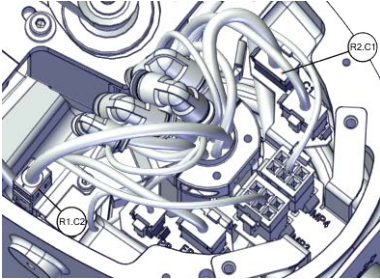

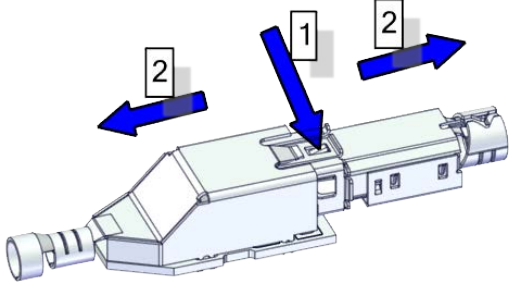
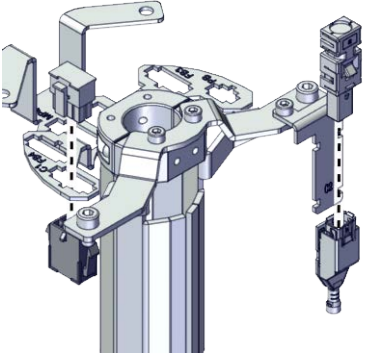

5.8.2 Replacing the axis-2 gear unit sub-assembly

Continued

	Action	Note
4	<p>For robots with C1 cabling</p> <p>Disconnect the connector.</p> <ul style="list-style-type: none"> • R2.C1 	
5	<p>For robots with C2 cabling</p> <p>Disconnect the connector.</p> <ul style="list-style-type: none"> • R1.C2 <p> Tip</p> <p>Cut the cable straps for the R1.C2 at the same time.</p> <p> Tip</p> <p>Take photos of the connector and cable position before disconnecting them, to have as a reference when reconnecting.</p> <p> Tip</p> <p>The connector clip has to be pressed (1) and pushed forward (2) to separate the R1.C2 (for C2 cabling).</p>  <p>xx1800002943</p>	<p>xx1900000070</p>
6	<p>Snap loose and remove the female head of the connectors from the bracket.</p>	 <p>xx1900000071</p>

Continues on next page

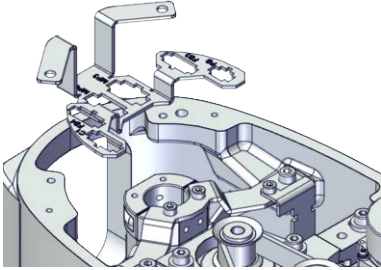
Removing the cable ferrule, bracket and protected bracket

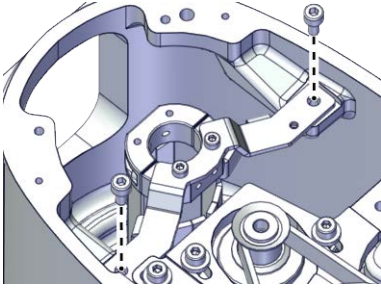

	Action	Note
1	 <p>DANGER</p> <p>Make sure that all supplies for electrical power, hydraulic pressure, and air pressure are turned off.</p>	
2	 <p>CAUTION</p> <p>For robots with protection type Clean Room Always cut the paint with a knife and grind the paint edge when disassembling parts of the robot! See <i>Cut the paint or surface on the robot before replacing parts on page 118.</i></p>	
3	<p>Take out the bracket from the outer arm.</p>  <p>Note</p> <p>The harness are not visible due to the cleanness requirements of the illustration. They are still existing inside the cable ferrule in the actual situation.</p>	 <p>xx1900000073</p>
4	<p>Remove the screws on the protected bracket.</p>  <p>Note</p> <p>The harness are not visible due to the cleanness requirements of the illustration. They are still existing inside the cable ferrule in the actual situation.</p>	 <p>xx1900000074</p>

Continues on next page

5 Repair

5.8.2 Replacing the axis-2 gear unit sub-assembly

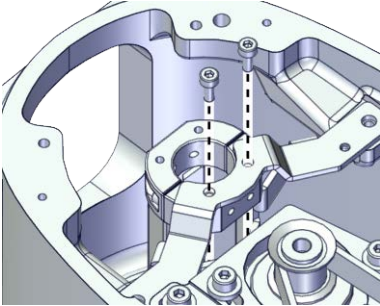
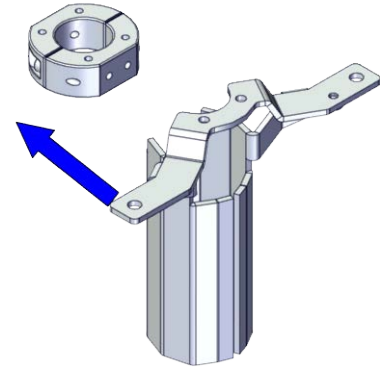
Continued

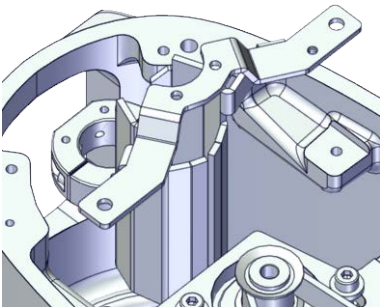

	Action	Note
5	<p>Remove the screws on the protected bracket to the cable ferrule to release the cable ferrule with cable.</p> <p> Note</p> <p>The harness are not visible due to the cleanness requirements of the illustration. They are still existing inside the cable ferrule in the actual situation.</p>	 <p>xx1900000075</p>  <p>xx1900000076</p>
6	<p>Remove the protected bracket.</p> <p> Tip</p> <p>Pull the protected bracket to the ball screw side to push the cable with the cable ferrule out from the protected bracket.</p> <p> Note</p> <p>The harness are not visible due to the cleanness requirements of the illustration. They are still existing inside the cable ferrule in the actual situation.</p>	 <p>xx1900000078</p>

Continues on next page

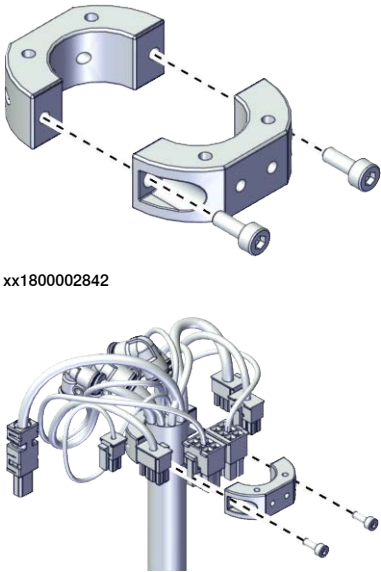
5.8.2 Replacing the axis-2 gear unit sub-assembly
Continued

	Action	Note
7	Remove the screws on the cable ferrule and take the cable ferrule out.	 <p>xx1800002842</p> <p>xx1800002849</p>

Removing the casting cover of the inner arm

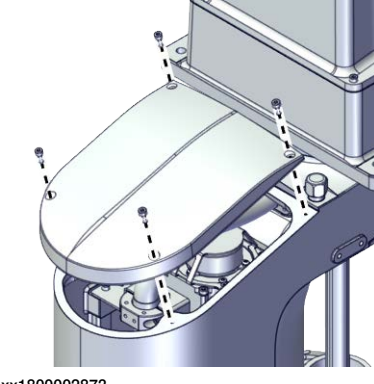
	Action	Note
1	 <p>DANGER</p> <p>Make sure that all supplies for electrical power, hydraulic pressure, and air pressure are turned off.</p>	
2	 <p>CAUTION</p> <p>For robots with protection type Clean Room Always cut the paint with a knife and grind the paint edge when disassembling parts of the robot! See Cut the paint or surface on the robot before replacing parts on page 118.</p>	
3	Remove the screws.	 <p>xx1800002873</p>
4	Remove the casting cover.	





Continues on next page

5 Repair

5.8.2 Replacing the axis-2 gear unit sub-assembly



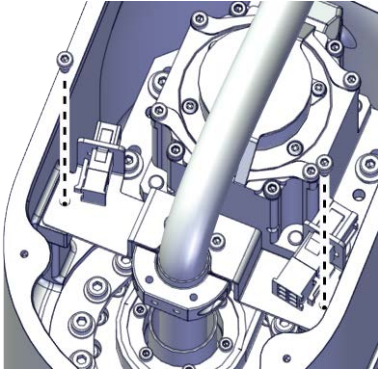
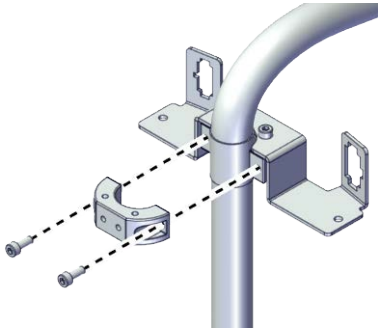

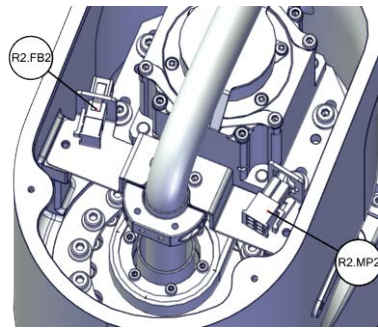
Continued

Removing the cable bracket at the axis -2 motor position in the inner arm

	Action	Note
1	 DANGER Make sure that all supplies for electrical power, hydraulic pressure, and air pressure are turned off.	
2	 CAUTION For robots with protection type Clean Room Always cut the paint with a knife and grind the paint edge when disassembling parts of the robot! See Cut the paint or surface on the robot before replacing parts on page 118 .	
3	Remove the screws.	 xx1800002874
4	Remove the screws on the cable ferrule to release the cable.	 xx1800002876
5	Disconnect the connectors. <ul style="list-style-type: none"> • R2.MP2 • R2.FB2  Tip Take photos of the connector and cable position before disconnecting them, to have as a reference when reconnecting.	 xx1800002875

Continues on next page

Removing the internal harness from the axis -2 gearbox position

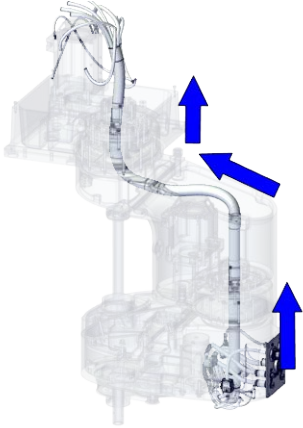
	Action	Note
1	 DANGER Make sure that all supplies for electrical power, hydraulic pressure, and air pressure are turned off.	
2	 CAUTION For robots with protection type Clean Room Always cut the paint with a knife and grind the paint edge when disassembling parts of the robot! See Cut the paint or surface on the robot before replacing parts on page 118 .	
3	Cut the cable straps for R2.MP3 and R2.MP4.  Tip Take photos of the cable straps position before cutting them, to have as a reference when routing the cable.	
4	Pull the internal harness out of the outer arm from the centre of the axis-2 gearbox.  Tip Wrap the connectors with the masking tape.  Tip Take photos of the connector and cable position before disconnecting them, to have as a reference when reconnecting.	 xx1800003411

Removing the axis-2 motor sub-assembly



	Action	Note
1	 DANGER Make sure that all supplies for electrical power, hydraulic pressure, and air pressure are turned off.	

Continues on next page

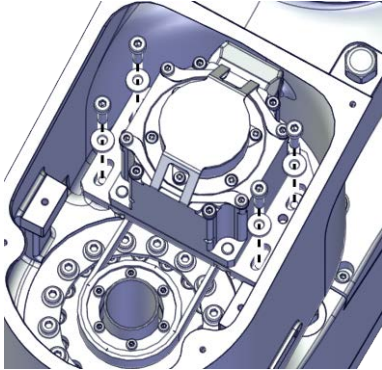

5 Repair

5.8.2 Replacing the axis-2 gear unit sub-assembly

Continued

	Action	Note
2	 CAUTION For robots with protection type Clean Room Always cut the paint with a knife and grind the paint edge when disassembling parts of the robot! See Cut the paint or surface on the robot before replacing parts on page 118 .	
3	Remove the screws and washers.	 xx1800002877
4	Remove the motor and the timing belt.  Tip Move the internal harness out of the way.	

Separating the outer arm from the inner arm

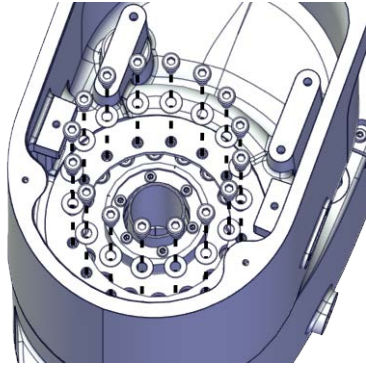

	Action	Note
1	 DANGER Make sure that all supplies for electrical power, hydraulic pressure, and air pressure are turned off.	
2	 CAUTION For robots with protection type Clean Room Always cut the paint with a knife and grind the paint edge when disassembling parts of the robot! See Cut the paint or surface on the robot before replacing parts on page 118 .	
3	Remove the screws and washers.	 xx1800003382

Continues on next page

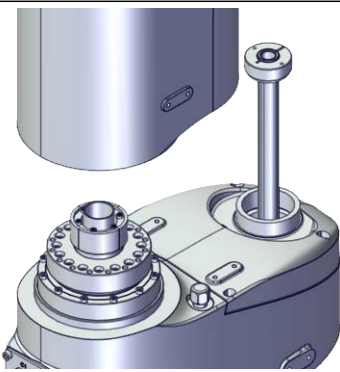
5.8.2 Replacing the axis-2 gear unit sub-assembly
Continued

	Action	Note
4	<p>Remove the outer arm with the axis-2 gear unit assembly from the inner arm.</p> <p> Tip</p> <p>Move the internal harness out of the way.</p>	 <p>xx1800003383</p>

Separating the axis-2 gear unit sub-assembly from the outer arm

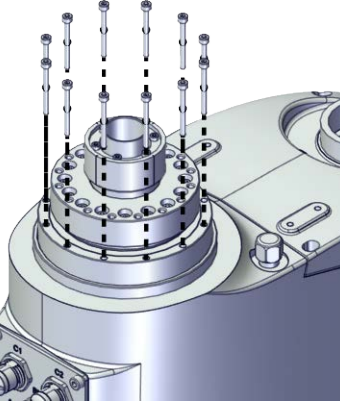

	Action	Note
1	<p> DANGER</p> <p>Make sure that all supplies for electrical power, hydraulic pressure, and air pressure are turned off.</p>	
2	<p> CAUTION</p> <p>For robots with protection type Clean Room Always cut the paint with a knife and grind the paint edge when disassembling parts of the robot! See Cut the paint or surface on the robot before replacing parts on page 118.</p>	
3	<p>Remove the screws and washers.</p>	 <p>xx1800003384</p>

Continues on next page

5 Repair

5.8.2 Replacing the axis-2 gear unit sub-assembly

Continued

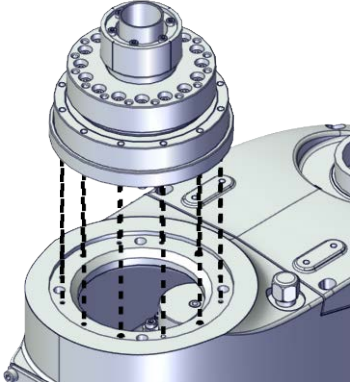
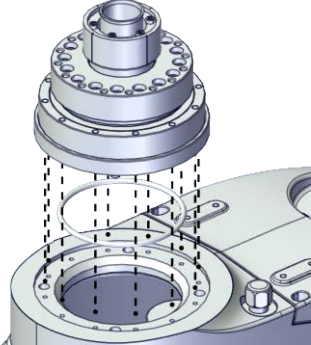
	Action	Note
4	<p>Remove the gear unit.</p> <p> Note</p> <p>For robots with protection class IP54 (option 3350-540)</p> <p>For robots with protection type Clean Room (option 3351-1)</p> <p>Remove the gear unit sub-assembly and the O-ring.</p> <p> Tip</p> <p>Check the O-ring and replace it if needed.</p> <p> Tip</p> <p>Move the internal harness out of the way.</p>	<p>For robots with protection class IP30 (option 3350-300)</p>  <p>xx1800003385</p> <p>For robots with protection class IP54 (option 3350-540)</p> <p>For robots with protection type Clean Room (option 3351-1)</p>  <p>xx1900001645</p>

Refitting the axis-2 gear unit sub-assembly





Use these procedures to refit the axis-2 gear unit sub-assembly.

Refitting the axis-2 gear unit sub-assembly to the outer arm

	Action	Note
1	<p>For robots with protection type Clean Room:</p> <p>Clean the joints that have been opened and wipe the parts free from particles with spirit on a lint free. See Cut the paint or surface on the robot before replacing parts on page 118</p> <p> Note</p> <p>After all repair work, wipe the Clean Room robot free from particles with spirit on a lint free cloth.</p>	

Continues on next page

5.8.2 Replacing the axis-2 gear unit sub-assembly
Continued

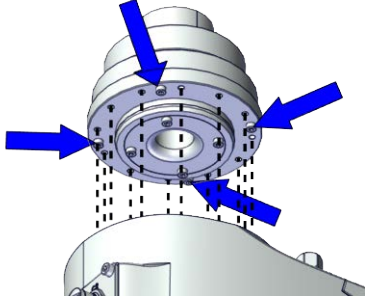
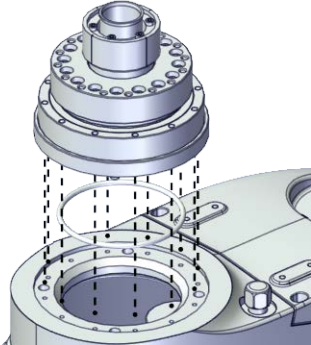
	Action	Note
2	<p> CAUTION</p> <p>Whenever parting/mating motor and gearbox, the gears may be damaged if excessive force is used.</p>	
3	<p>Refit the gear unit according to the location pin.</p> <p> Note</p> <p>For robots with protection class IP54 (option 3350-540)</p> <p>For robots with protection type Clean Room (option 3351-1)</p> <p>Refit the gear unit and the O-ring according to the location pin.</p> <p> Tip</p> <p>Check the O-ring and replace it if needed.</p> <p> Tip</p> <p>When the gear unit is in the right position, you can hear a clear "Click".</p>	<p>For robots with protection class IP30 (option 3350-300)</p>  <p>xx1800003386</p> <p>For robots with protection class IP54 (option 3350-540)</p> <p>For robots with protection type Clean Room (option 3351-1)</p>  <p>xx1900001645</p>

Continues on next page



5 Repair

5.8.2 Replacing the axis-2 gear unit sub-assembly

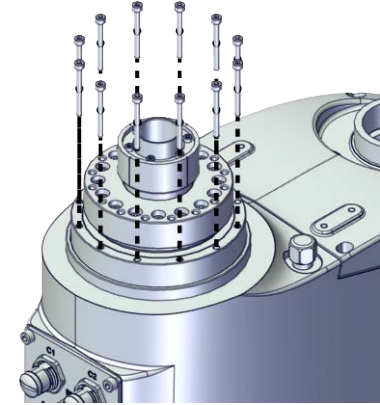
Continued

	Action	Note
4	Refit the screws.	<p>Screws: Hex socket head cap screw M3x30 12.9 Lafre 2C2B/FC6.9 (12 pcs) Tightening torque: 0.5 Nm-1 Nm-1.8 Nm $\pm 10\%$</p>  <p>xx1800003384</p>

Refitting the outer arm to the inner arm

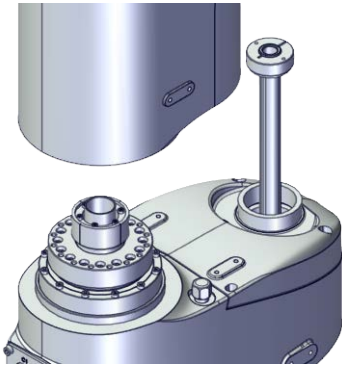

	Action	Note
1	<p>For robots with protection type Clean Room: Clean the joints that have been opened and wipe the parts free from particles with spirit on a lint free. See Cut the paint or surface on the robot before replacing parts on page 118</p> <p> Note</p> <p>After all repair work, wipe the Clean Room robot free from particles with spirit on a lint free cloth.</p>	
2	<p> CAUTION</p> <p>Whenever parting/mating motor and gearbox, the gears may be damaged if excessive force is used.</p>	
3	<p>Refit the outer arm with the gear unit to the inner arm. (Location pin?)</p> <p> Tip</p> <p>When the gear unit is in the right position, you can hear a clear "Click".</p>	 <p>xx1800003383</p>

Continues on next page

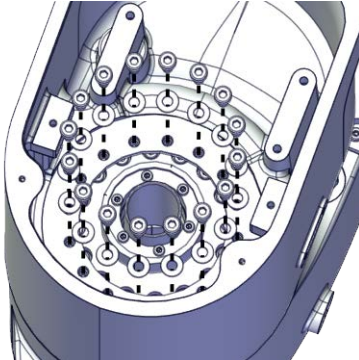
5.8.2 Replacing the axis-2 gear unit sub-assembly
Continued

	Action	Note
4	Refit the screws.	<p>Screws: Hex socket head cap screw M4x12 12.9 Lafre 2C2B/FC6.9 (16 pcs)</p> <p>Washers: Spring washer 9x4.3x1 Steel (16 pcs)</p> <p>Tightening torque: 0.5 Nm-1 Nm-2 Nm-4.5 Nm ±10%</p>  <p>xx1800003382</p>

Refitting the axis-2 motor sub-assembly

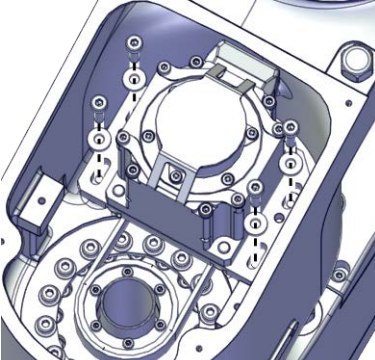



	Action	Note
1	<p>For robots with protection type Clean Room: Clean the joints that have been opened and wipe the parts free from particles with spirit on a lint free. See Cut the paint or surface on the robot before replacing parts on page 118</p> <p> Note</p> <p>After all repair work, wipe the Clean Room robot free from particles with spirit on a lint free cloth.</p>	
2	Refit the axis-2 timing belt onto the pulley on the axis-2 gearbox.	Screws: Hex socket head cap screw M4x20 12.9 Lafre 2C2B/FC6.9 (4 pcs)
3	<p>Refit the motor and refit the timing belt to the motor. Ensure that the belt runs correctly in the grooves.</p> <p> Tip</p> <p>Move the internal harness out of the way.</p>	<p>Washers: Washer 4.3x10x2 steel (4 pcs)</p> <p>Tightening torque: 3 Nm ±10%</p>  <p>xx1800002877</p>
4	Refit the screws and washers without fully tightened.	<p>Timing belt: 3HAC061861-001</p>

Continues on next page

5 Repair

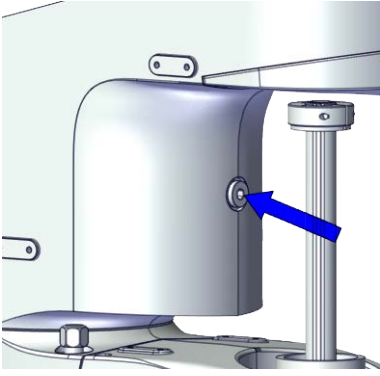

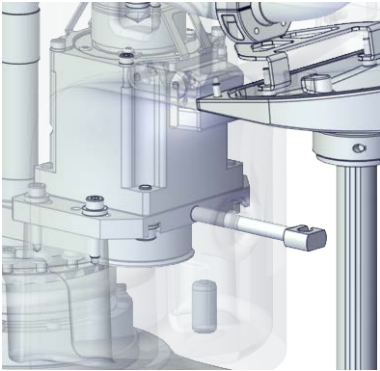
5.8.2 Replacing the axis-2 gear unit sub-assembly

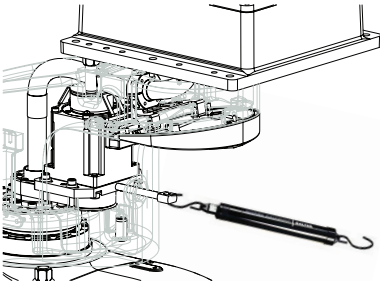
Continued

	Action	Note
5	Remove the plug.	 xx1800002878
6	Install the axis-1&2 belt tension adjustment tool to the motor through the hole.  Note Just tighten the tool.	Belt tension adjustment tool set, axis 1&2:-  xx1800002879
7	Use a handheld dynamometer hooking to the screw and pull the dynamometer to make the tension falling in the allowed force range.  Note During the measurement, make sure that all interferences that may affect the force are removed. Pay attention to the force application direction.  Tip If the ball screw will interfere with the handheld dynamometer, adjust the ball screw manually.	Used belt: 45-51N New belt:65-71N  xx1900000095

Continues on next page

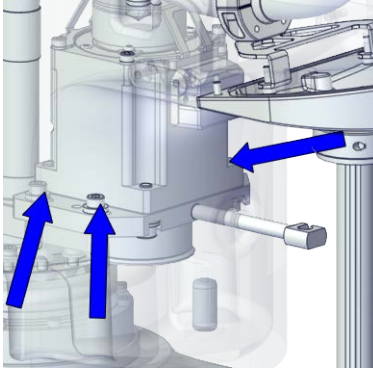
5.8.2 Replacing the axis-2 gear unit sub-assembly
Continued

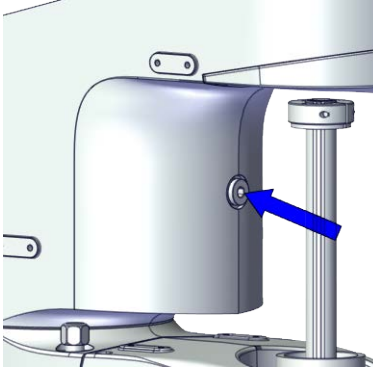
	Action	Note
8	Fasten the screws to the recommended tightening torque.	Tightening torque: 3 Nm \pm 10%  xx1800002880
9	Use a sonic tension meter to measure the timing belt tension.	Used belt: 193-236Hz New belt:229-293Hz
10	If the timing belt tension does not meet the requirement, loosen the motor screws and readjust.	
11	Remove the axis-1&2 belt tension adjustment tool.	
12	Refit the plug.  Tip Just tighten it.	Tightening torque: 2 Nm \pm 10%  xx1800002878

Inserting the internal harness through the axis -2 gearbox position

	Action	Note
1	For robots with protection type Clean Room: Clean the joints that have been opened and wipe the parts free from particles with spirit on a lint free. See Cut the paint or surface on the robot before replacing parts on page 118  Note After all repair work, wipe the Clean Room robot free from particles with spirit on a lint free cloth.	

Continues on next page



5 Repair

5.8.2 Replacing the axis-2 gear unit sub-assembly

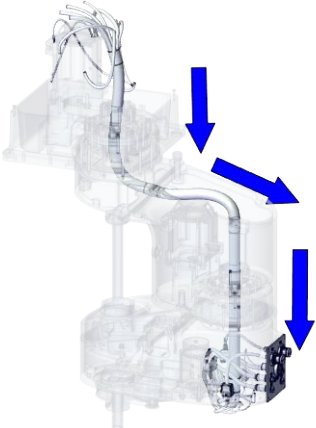
Continued

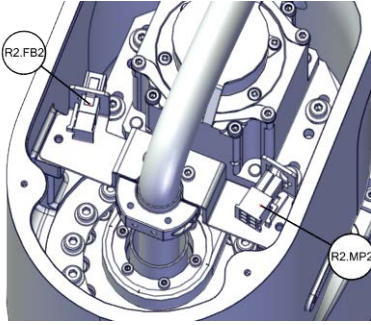

	Action	Note
2	<p>Insert the internal harness into the outer arm through the centre of the axis-2 gearbox.</p> <p> Tip</p> <p>Wrap the connectors with the masking tape.</p>	 <p>xx1800003412</p>
3	Secure the R2.MP3 and R2.MP4 with cable straps.	

Refitting the cable bracket

	Action	Note
1	<p>For robots with protection type Clean Room: Clean the joints that have been opened and wipe the parts free from particles with spirit on a lint free. See Cut the paint or surface on the robot before replacing parts on page 118</p> <p> Note</p> <p>After all repair work, wipe the Clean Room robot free from particles with spirit on a lint free cloth.</p>	
2	<p>Reconnect the connectors.</p> <ul style="list-style-type: none"> • R2.MP2 • R2.FB2 <p> Tip</p> <p>Take photos of the connector and cable position before disconnecting them, to have as a reference when reconnecting.</p> <p> Tip</p> <p>See the number markings on the connectors for help to find the corresponding connector.</p>	 <p>xx1800002875</p>
3	Lay the internal harness in a natural state without distortion.	

Continues on next page

5.8.2 Replacing the axis-2 gear unit sub-assembly
Continued

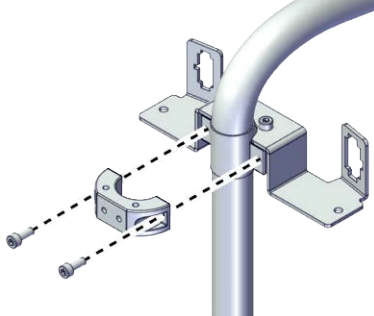
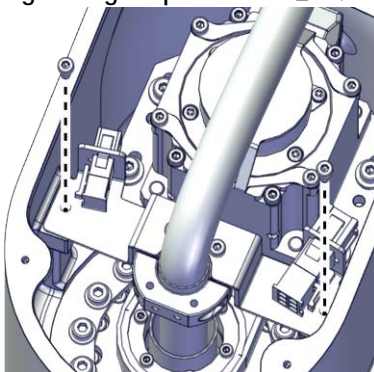
	Action	Note
4	<p>Refit the cable ferrule on the cable at the marked position and secure with screws.</p> <p> Tip</p> <p>The position with wrapped tape is the marked position for the cable ferrule.</p> <p> Tip</p> <p>Align all the cable ferrules so that the cable is in a natural bending position to avoid twisting.</p>	<p>Screws: Hex socket head cap screw M3x8 12.9 Lafre 2C2B/FC6.9 (2 pcs)</p> <p>Tightening torque: 1.5 Nm ±10%</p>  <p>xx1800002876</p>
5	<p>Refit the bracket and secure with the screws.</p>	<p>Screws: Hex socket head cap screw M3x5 12.9 Lafre 2C2B/FC6.9 (2 pcs)</p> <p>Tightening torque: 1.5 Nm ±10%</p>  <p>xx1800002874</p>

Refitting the casting cover of the inner arm



	Action	Note
1	<p>For robots with protection type Clean Room: Clean the joints that have been opened and wipe the parts free from particles with spirit on a lint free. See Cut the paint or surface on the robot before replacing parts on page 118</p> <p> Note</p> <p>After all repair work, wipe the Clean Room robot free from particles with spirit on a lint free cloth.</p>	

Continues on next page

5 Repair

5.8.2 Replacing the axis-2 gear unit sub-assembly

Continued

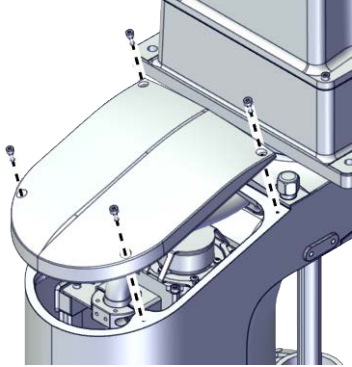
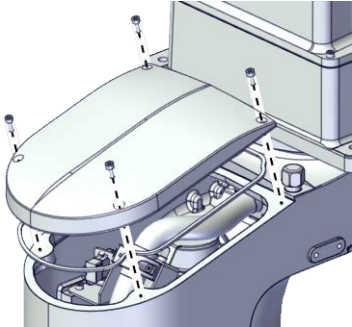



	Action	Note
2	<p>Refit the casting cover.</p> <p> Note</p> <p>For robots with protection class IP54 (option 3350-540)</p> <p>For robots with protection type Clean Room (option 3351-1)</p> <p>Check the gasket for the casting cover before refitting the base cover.</p> <p> Tip</p> <p>Replace the gasket if needed.</p>	<p>Screw: Hex socket head cap screw M3x8 12.9 Lafre 2C2B/FC6.9 (4 pcs)</p> <p>Tightening torque: 1.2 Nm \pm10%</p> <p>For robots with protection class IP30 (option 3350-300)</p>  <p>xx1800002873</p> <p>For robots with protection class IP54 (option 3350-540)</p> <p>For robots with protection type Clean Room (option 3351-1)</p>  <p>xx1900001637</p>
3	<p>Refit the screws.</p>	

Refitting the cable ferrule and protected bracket

	Action	Note
1	<p>For robots with protection type Clean Room:</p> <p>Clean the joints that have been opened and wipe the parts free from particles with spirit on a lint free. See Cut the paint or surface on the robot before replacing parts on page 118</p> <p> Note</p> <p>After all repair work, wipe the Clean Room robot free from particles with spirit on a lint free cloth.</p>	
2	<p>Lay the internal harness in a natural state without distortion.</p>	

Continues on next page

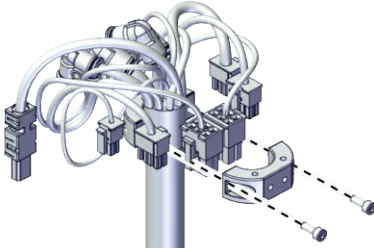
5.8.2 Replacing the axis-2 gear unit sub-assembly
Continued

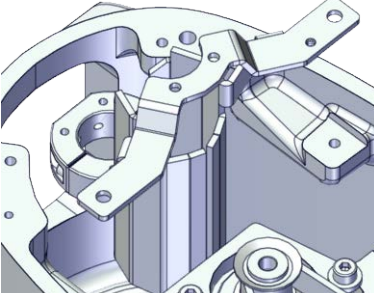

	Action	Note
3	<p>Refit the cable ferrule and secure it with the screws.</p> <p> Tip</p> <p>The air hoses should face the process hub side.</p> <p> Tip</p> <p>The position with wrapped tape is the marked position for the cable ferrule.</p> <p> Tip</p> <p>Align all the cable ferrules so that the cable is in a natural bending position to avoid twisting.</p>	<p>Screws: Hex socket head cap screw M3x8 12.9 Lafre 2C2B/FC6.9 (2 pcs)</p> <p>Tightening torque: 1.5 Nm ±10%</p>  <p>xx1800002849</p>
4	<p>Refit the protected bracket.</p> <p> Tip</p> <p>Do not secure it with the screws before the cable ferrule installed well.</p> <p> Note</p> <p>The harness are not visible due to the cleanness requirements of the illustration. They are still existing inside the cable ferrule in the actual situation.</p>	<p>Screws: Hex socket head cap screw M4x8 12.9 Lafre 2C2B/FC6.9 (2 pcs)</p> <p>Tightening torque: 4 Nm ±10%</p>  <p>xx1900000078</p>

Continues on next page

5 Repair

5.8.2 Replacing the axis-2 gear unit sub-assembly

Continued

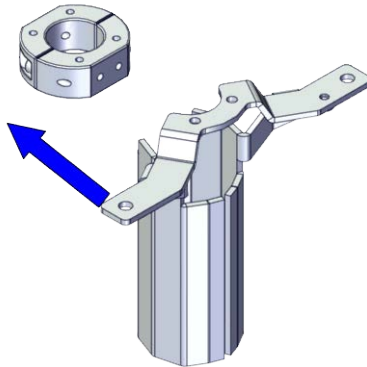
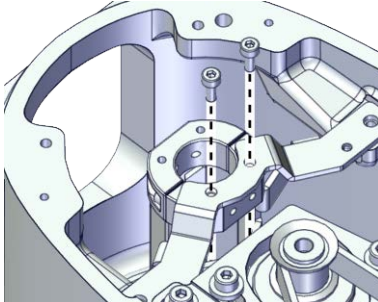



	Action	Note
5	<p>Secure the cable ferrule to the protected bracket.</p> <p> Tip</p> <p>Align all the cable ferrules so that the cable is in a natural bending position to avoid twisting.</p> <p> Note</p> <p>The harness are not visible due to the cleanliness requirements of the illustration. They are still existing inside the cable ferrule in the actual situation.</p>	<p>Screws: Hex socket head cap screw M3x5 12.9 Lafre 2C2B/FC6.9 (2 pcs)</p> <p>Tightening torque: 1.5 Nm \pm10%</p>  <p>xx190000076</p>  <p>xx190000075</p>

Reconnecting the connector for PB

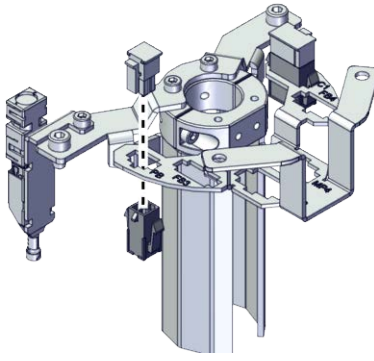

	Action	Note
1	<p>For robots with protection type Clean Room: Clean the joints that have been opened and wipe the parts free from particles with spirit on a lint free. See Cut the paint or surface on the robot before replacing parts on page 118</p> <p> Note</p> <p>After all repair work, wipe the Clean Room robot free from particles with spirit on a lint free cloth.</p>	

Continues on next page

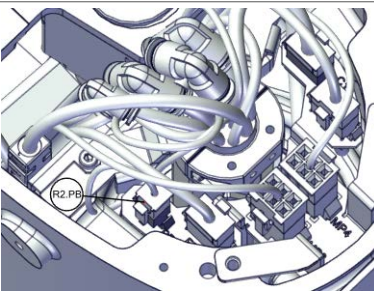
5.8.2 Replacing the axis-2 gear unit sub-assembly
Continued

	Action	Note
2	<p>Insert the female head of the PB connector to the bracket accordingly.</p> <p> Tip</p> <p>The mistake proofing measure has been applied to the connectors, the connectors may be damaged if excessive force is used.</p> <p> Note</p> <p>The harness are not visible due to the cleanness requirements of the illustration. They are still existing inside the cable ferrule in the actual situation.</p>	 <p>xx1900000069</p>
3	<p>Reconnect the connector.</p> <ul style="list-style-type: none"> • R2.PB <p> Tip</p> <p>See the number markings on the connectors for help to find the corresponding connector.</p>	 <p>xx1900000068</p>

Reconnecting the air hoses, CP/CS cabling and Ethernet cabling (if equipped)







	Action	Note
1	<p>For robots with protection type Clean Room: Clean the joints that have been opened and wipe the parts free from particles with spirit on a lint free. See Cut the paint or surface on the robot before replacing parts on page 118</p> <p> Note</p> <p>After all repair work, wipe the Clean Room robot free from particles with spirit on a lint free cloth.</p>	
2	<p>Route the air hoses on the process hub behind the protected bracket.</p> <p> CAUTION</p> <p>Correct cable routing is highly important. If the cables are routed and secured incorrectly the cables can be damaged.</p>	

Continues on next page

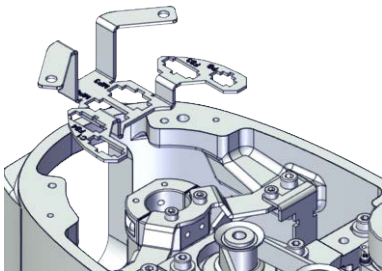
5 Repair

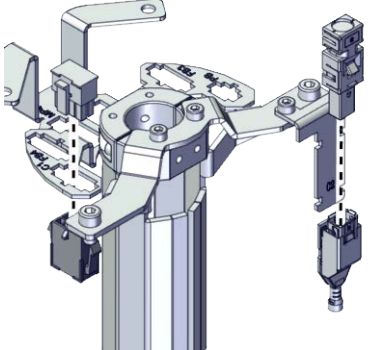

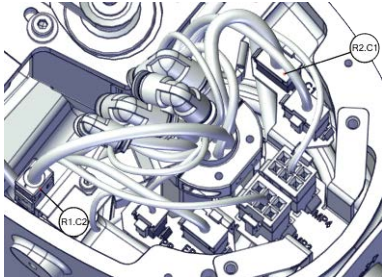

5.8.2 Replacing the axis-2 gear unit sub-assembly

Continued

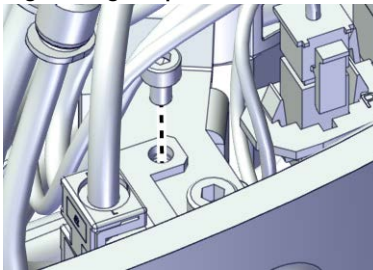

	Action	Note
3	<p>Refit the bracket to the outer arm without screws.</p> <p> Note</p> <p>The harness are not visible due to the cleanness requirements of the illustration. They are still existing inside the cable ferrule in the actual situation.</p>	 <p>xx1900000073</p>
4	<p>Insert the female head of the C1 cabling connector to the bracket accordingly.</p> <p> Tip</p> <p>The mistake proofing measure has been applied to the connectors, the connectors may be damaged if excessive force is used.</p>	 <p>xx1900000071</p>
5	<p>For robots with C1 cabling</p> <p>Reconnect the connector.</p> <ul style="list-style-type: none"> • R2.C1 <p> Tip</p> <p>See the number markings on the air hoses for help to find the corresponding air hoses. The air hoses with the same number connect to the same L-shaped connector.</p> <p> Note</p> <p>The harness are not visible due to the cleanness requirements of the illustration. They are still existing inside the cable ferrule in the actual situation.</p>	 <p>xx1900000070</p>
6	<p>For robots with C2 cabling</p> <p>Reconnect the connector.</p> <ul style="list-style-type: none"> • R1.C2 <p> Tip</p> <p>See the number markings on the air hoses for help to find the corresponding air hoses. The air hoses with the same number connect to the same L-shaped connector.</p>	
7	<p>Secure the C2 cabling to the C2 bracket with the cable straps.</p>	

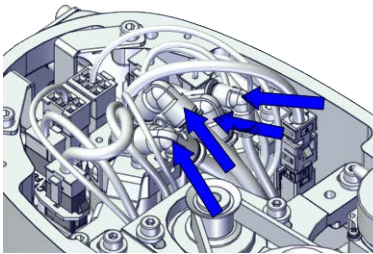
Continues on next page

5.8.2 Replacing the axis-2 gear unit sub-assembly
Continued

	Action	Note
8	Secure the C2 bracket to the bracket with screw.	<p>Screws: Hex socket head cap screw M3x5 12.9 Lafre 2C2B/FC6.9 (1 pcs)</p> <p>Tightening torque: 4 Nm \pm10%</p>  <p>xx190000098</p>
9	<p>Reconnect the air hoses in a cross pattern with the L-shaped connectors.</p>  Tip See the number markings on the air hoses for help to find the corresponding air hoses. The air hoses with the same number connect to the same Y-shaped connector.	 <p>xx1800002837</p>
10	<p>Route and secure the cabling with cable straps if needed.</p>  CAUTION Correct cable routing is highly important. If the cables are routed and secured incorrectly the cables can be damaged.	

Reconnecting the connectors for axis-3 motor



	Action	Note
1	<p>For robots with protection type Clean Room: Clean the joints that have been opened and wipe the parts free from particles with spirit on a lint free. See Cut the paint or surface on the robot before replacing parts on page 118</p>  Note After all repair work, wipe the Clean Room robot free from particles with spirit on a lint free cloth.	
2	<p>Route the cabling on the axis-3 motor behind the protected bracket to the bracket.</p>  CAUTION Correct cable routing is highly important. If the cables are routed and secured incorrectly the cables can be damaged.	

Continues on next page

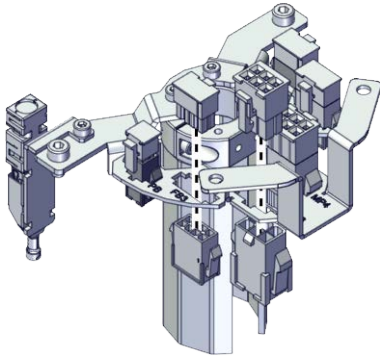

5 Repair

5.8.2 Replacing the axis-2 gear unit sub-assembly

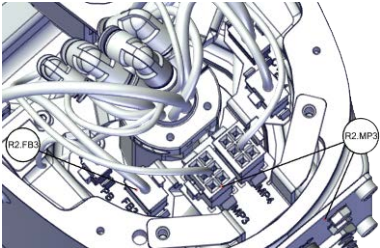
Continued



	Action	Note
3	<p>Insert the female head of the connectors to the bracket accordingly.</p> <p> Tip</p> <p>The mistake proofing measure has been applied to the connectors, the connectors may be damaged if excessive force is used.</p>	 <p>xx1900000064</p>
4	<p>Reconnect the connectors.</p> <ul style="list-style-type: none"> • R2.MP3 • R2.FB3 <p> Tip</p> <p>See the number markings on the connectors for help to find the corresponding connector.</p>	 <p>xx1900000063</p>

Reconnecting the connectors for axis-4 motor

	Action	Note
1	<p>For robots with protection type Clean Room: Clean the joints that have been opened and wipe the parts free from particles with spirit on a lint free. See Cut the paint or surface on the robot before replacing parts on page 118</p> <p> Note</p> <p>After all repair work, wipe the Clean Room robot free from particles with spirit on a lint free cloth.</p>	
2	<p>Route the cabling on the axis-4 motor behind the protected bracket to the bracket.</p> <p> CAUTION</p> <p>Correct cable routing is highly important. If the cables are routed and secured incorrectly the cables can be damaged.</p>	

Continues on next page

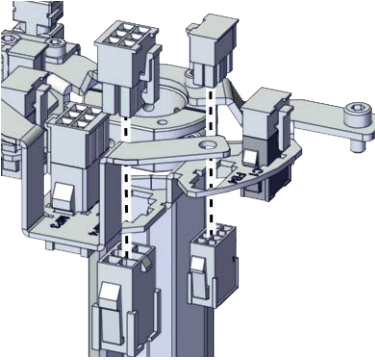
5.8.2 Replacing the axis-2 gear unit sub-assembly
Continued

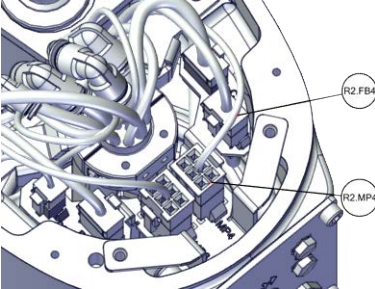
	Action	Note
	<p>Insert the female head of the connectors to the bracket accordingly.</p> <p> Tip</p> <p>The mistake proofing measure has been applied to the connectors, the connectors may be damaged if excessive force is used.</p>	 <p>xx190000066</p>
3	<p>Reconnect the connectors.</p> <ul style="list-style-type: none"> • R2.MP4 • R2.FB4 <p> Tip</p> <p>See the number markings on the connectors for help to find the corresponding connector.</p>	 <p>xx190000065</p>

Refitting the bracket for the process hub

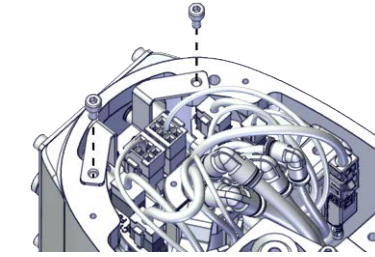
	Action	Note
1	<p>For robots with protection type Clean Room: Clean the joints that have been opened and wipe the parts free from particles with spirit on a lint free. See Cut the paint or surface on the robot before replacing parts on page 118</p> <p> Note</p> <p>After all repair work, wipe the Clean Room robot free from particles with spirit on a lint free cloth.</p>	
2	<p>Secure the bracket with screws.</p>	<p>Screws: Hex socket head cap screw M4x8 12.9 Lafre 2C2B/FC6.9 (2 pcs) Tightening torque: 4 Nm ±10%</p>  <p>xx1800002839</p>

Continues on next page

5 Repair

5.8.2 Replacing the axis-2 gear unit sub-assembly



Continued

Refitting the cover of the outer arm

	Action	Note
1	<p>For robots with protection type Clean Room: Clean the joints that have been opened and wipe the parts free from particles with spirit on a lint free. See Cut the paint or surface on the robot before replacing parts on page 118</p> <p> Note</p> <p>After all repair work, wipe the Clean Room robot free from particles with spirit on a lint free cloth.</p>	

Continues on next page

5.8.2 Replacing the axis-2 gear unit sub-assembly
Continued

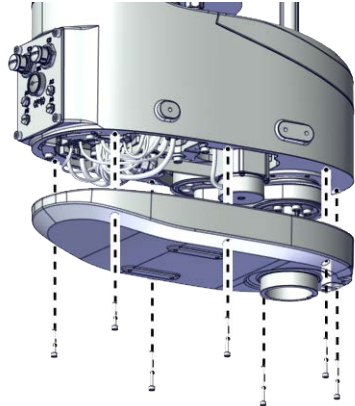
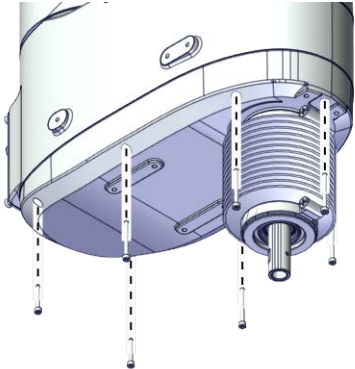
	Action	Note
2	<p>Refit the cover.</p> <p> Note</p> <p>For robots with protection class IP54 (option 3350-540)</p> <p>For robots with protection type Clean Room (option 3351-1)</p> <p>Refit the cover with bellow and housing.</p> <p>Check the gasket on the outer arm cover.</p> <p> Tip</p> <p>Replace the gasket if needed.</p>	<p>For IRB 910INV-3/0.35:</p> <p>Screw: Hex socket head cap screw M3x20 12.9 Lafre 2C2B/FC6.9 (2 pcs)</p> <p>Hex socket head cap screw M3x30 12.9 Lafre 2C2B/FC6.9 (5 pcs)</p> <p>Tightening torque: 1.2 Nm ±10%</p> <p>For IRB 910INV-6/0.55:</p> <p>Screw: Hex socket head cap screw M3x20 12.9 Lafre 2C2B/FC6.9 (2 pcs)</p> <p>Hex socket head cap screw M3x30 12.9 Lafre 2C2B/FC6.9 (7 pcs)</p> <p>Tightening torque: 1.2 Nm ±10%</p> <p>For robots with protection class IP30 (option 3350-300)</p>
3	<p>Refit the screws.</p>	 <p>xx1800002836</p> <p>For robots with protection class IP54 (option 3350-540)</p> <p>For robots with protection type Clean Room (option 3351-1)</p>  <p>xx1900001631</p>

Continues on next page

5 Repair

5.8.2 Replacing the axis-2 gear unit sub-assembly

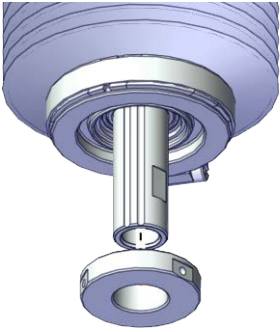
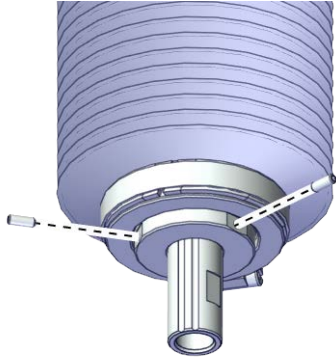

Continued

Refitting the lower cover

	Action	Note
1	<p>For robots with protection type Clean Room: Clean the joints that have been opened and wipe the parts free from particles with spirit on a lint free. See Cut the paint or surface on the robot before replacing parts on page 118</p> <p> Note</p> <p>After all repair work, wipe the Clean Room robot free from particles with spirit on a lint free cloth.</p>	
2	<p>For robots with protection class IP54 (option 3350-540) For robots with protection type Clean Room (option 3351-1) Refit the lower cover to the ball screw.</p>	 <p>xx1900001607</p>
3	<p>For robots with protection class IP54 (option 3350-540) For robots with protection type Clean Room (option 3351-1) Refit the locking screws.</p>	<p>Screws: Hexagon socket set screws with flat point, ISO 4026 stainless steel M3x8 (2 pcs) Tightening torque: 0.6 Nm ±10%</p>  <p>xx1900001606</p>

Continues on next page

Concluding procedure

	Action	Note
1	<p>For robots with protection type Clean Room: Seal and paint the joints that have been opened. See Cut the paint or surface on the robot before replacing parts on page 118</p> <p> Note</p> <p>After all repair work, wipe the Clean Room robot free from particles with spirit on a lint free cloth.</p>	
2	Recalibrate the robot.	Calibration is detailed in section Calibration on page 771 .
3	<p> DANGER</p> <p>Make sure all safety requirements are met when performing the first test run. See Test run after installation, maintenance, or repair on page 56.</p>	

This page is intentionally left blank

6 Calibration

6.1 Introduction to calibration

6.1.1 Introduction and calibration terminology

Calibration information

This chapter includes general information about the recommended calibration methods and also the detailed procedures for updating the revolution counters, checking the calibration position etc.

Detailed instructions of how to perform Axis Calibration are given on the FlexPendant during the calibration procedure. To prepare calibration with Axis Calibration method, see [Calibrating with Axis Calibration method on page 797](#).

Calibration terminology

Term	Definition
Calibration method	A collective term for several methods that might be available for calibrating the ABB robot. Each method contains calibration routines.
Synchronization position	Known position of the complete robot where the angle of each axis can be checked against visual synchronization marks.
Calibration position	Known position of the complete robot that is used for calibration of the robot.
Standard calibration	A generic term for all calibration methods that aim to move the robot to calibration position.
Fine calibration	A calibration routine that generates a new zero position of the robot.
Reference calibration	<p>A calibration routine that in the first step generates a reference to current zero position of the robot. The same calibration routine can later on be used to recalibrate the robot back to the same position as when the reference was stored.</p> <p>This routine is more flexible compared to fine calibration and is used when tools and process equipment are installed.</p> <p>Requires that a reference is created before being used for recalibrating the robot.</p> <p>Requires that the robot is dressed with the same tools and process equipment during calibration as during creation of the reference values.</p>
Update revolution counter	A calibration routine to make a rough calibration of each manipulator axis.
Synchronization mark	Visual marks on the robot axes. When marks are aligned, the robot is in synchronization position.

6 Calibration

6.1.2 Calibration methods

6.1.2 Calibration methods

Overview

This section specifies the different types of calibration and the calibration methods that are supplied by ABB.

Types of calibration

Type of calibration	Description	Calibration method
Standard calibration	The calibrated robot is positioned at calibration position. Standard calibration data is found on the SMB (serial measurement board) or EIB in the robot.	Axis Calibration ⁱ
Absolute accuracy calibration (optional)	Based on standard calibration, and besides positioning the robot at synchronization position, the Absolute accuracy calibration also compensates for: <ul style="list-style-type: none">Mechanical tolerances in the robot structureDeflection due to load Absolute accuracy calibration focuses on positioning accuracy in the Cartesian coordinate system for the robot. Absolute accuracy calibration data is found on the serial measurement board (SMB) or other robot memory. A robot calibrated with Absolute accuracy has the option information printed on its name plate (OmniCore). To regain 100% Absolute accuracy performance, the robot must be recalibrated for absolute accuracy after repair or maintenance that affects the mechanical structure.	CalibWare

ⁱ Only axes 1 and 2 can be calibrated using Axis Calibration method.

Brief description of calibration methods

Axis Calibration method

Axis Calibration is a standard calibration method for calibration of IRB 910INV. It is the recommended method in order to achieve proper performance.

The following routines are available for the Axis Calibration method:

- Fine calibration
- Update revolution counters
- Reference calibration

The calibration equipment for Axis Calibration is delivered as a toolkit.

An introduction to the calibration method is given in this manual, see [Calibrating with Axis Calibration method on page 797](#).

The actual instructions of how to perform the calibration procedure and what to do at each step is given on the FlexPendant. You will be guided through the calibration procedure, step by step.

Continues on next page

CalibWare - Absolute Accuracy calibration

The CalibWare tool guides through the calibration process and calculates new compensation parameters. This is further detailed in the *Application manual - CalibWare Field*.

If a service operation is done to a robot with the option Absolute Accuracy, a new absolute accuracy calibration is required in order to establish full performance. For most cases after replacements that do not include taking apart the robot structure, standard calibration is sufficient.

The Absolute Accuracy option varies according to the robot mounting position. This is printed on the robot name plate for each robot. The robot must be in the correct mounting position when it is recalibrated for absolute accuracy.

References

Article numbers for the calibration tools are listed in the section [Special tools on page 841](#).

6 Calibration

6.1.3 When to calibrate

6.1.3 When to calibrate

When to calibrate

The system must be calibrated if any of the following situations occur.

The resolver values are changed

If resolver values are changed, the robot must be re-calibrated using the calibration methods supplied by ABB. Calibrate the robot carefully with standard calibration, according to information in this manual.

If the robot has *absolute accuracy* calibration, it is also recommended, but not always necessary to calibrate for new absolute accuracy.

The resolver values will change when parts affecting the calibration position are replaced on the robot, for example motors or parts of the transmission.

The revolution counter memory is lost

If the revolution counter memory is lost, the counters must be updated. See [Updating revolution counters on page 780](#). This will occur when:

- The battery is discharged
- A resolver error occurs
- The signal between a resolver and measurement board is interrupted
- A robot axis is moved with the control system disconnected

The revolution counters must also be updated after the robot and controller are connected at the first installation.

The robot is rebuilt

If the robot is rebuilt, for example, after a crash or when the reachability of a robot is changed, it needs to be re-calibrated for new resolver values.

If the robot has *absolute accuracy* calibration, it needs to be calibrated for new absolute accuracy.

6.2 Synchronization marks and axis movement directions

6.2.1 Synchronization marks and synchronization position for axes

Introduction

This section shows the position of the synchronization marks and the synchronization position for each axis.

Synchronization marks, IRB 910INV

IP30

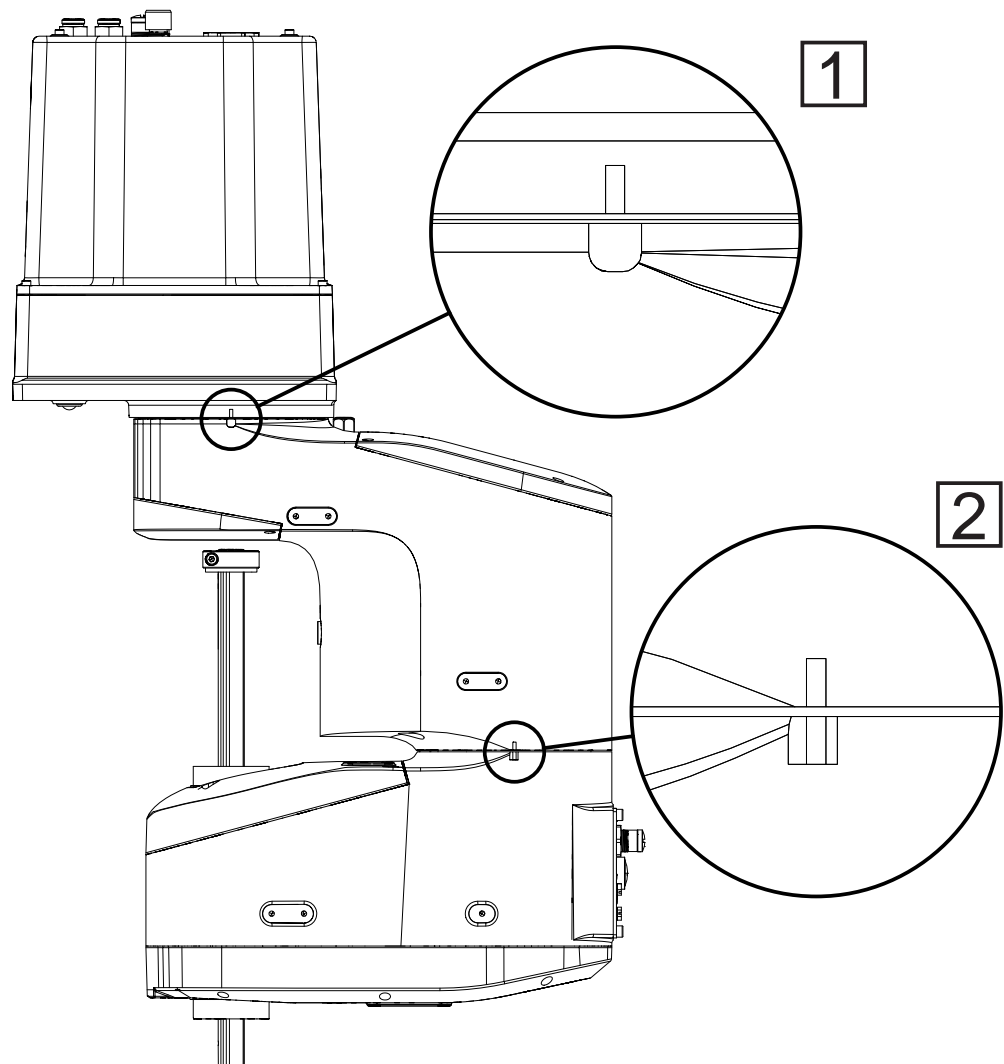

xx190000146

Continues on next page

6 Calibration

6.2.1 Synchronization marks and synchronization position for axes

Continued

Clean Room/ IP54

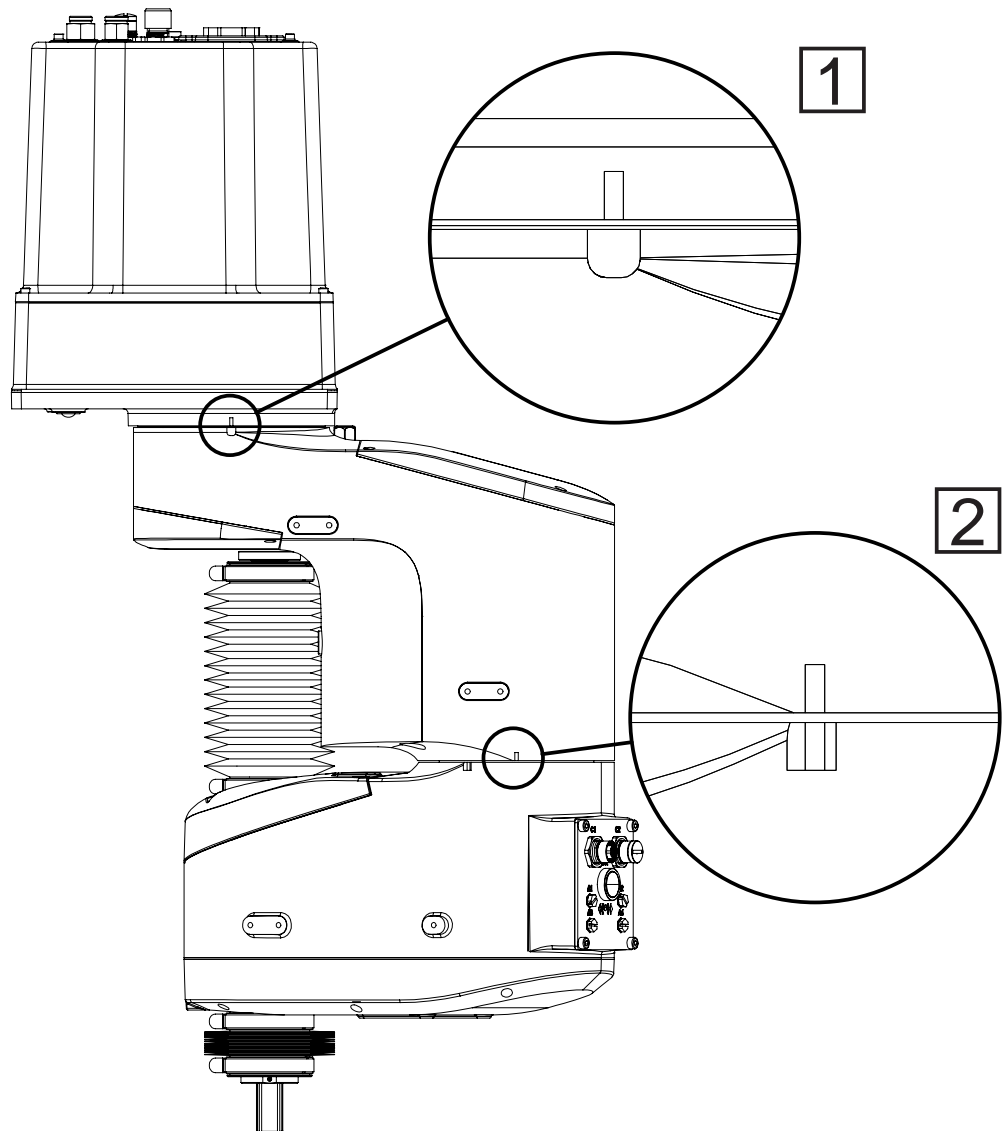

xx1900001710

IP30

Continues on next page

6.2.1 Synchronization marks and synchronization position for axes

Continued

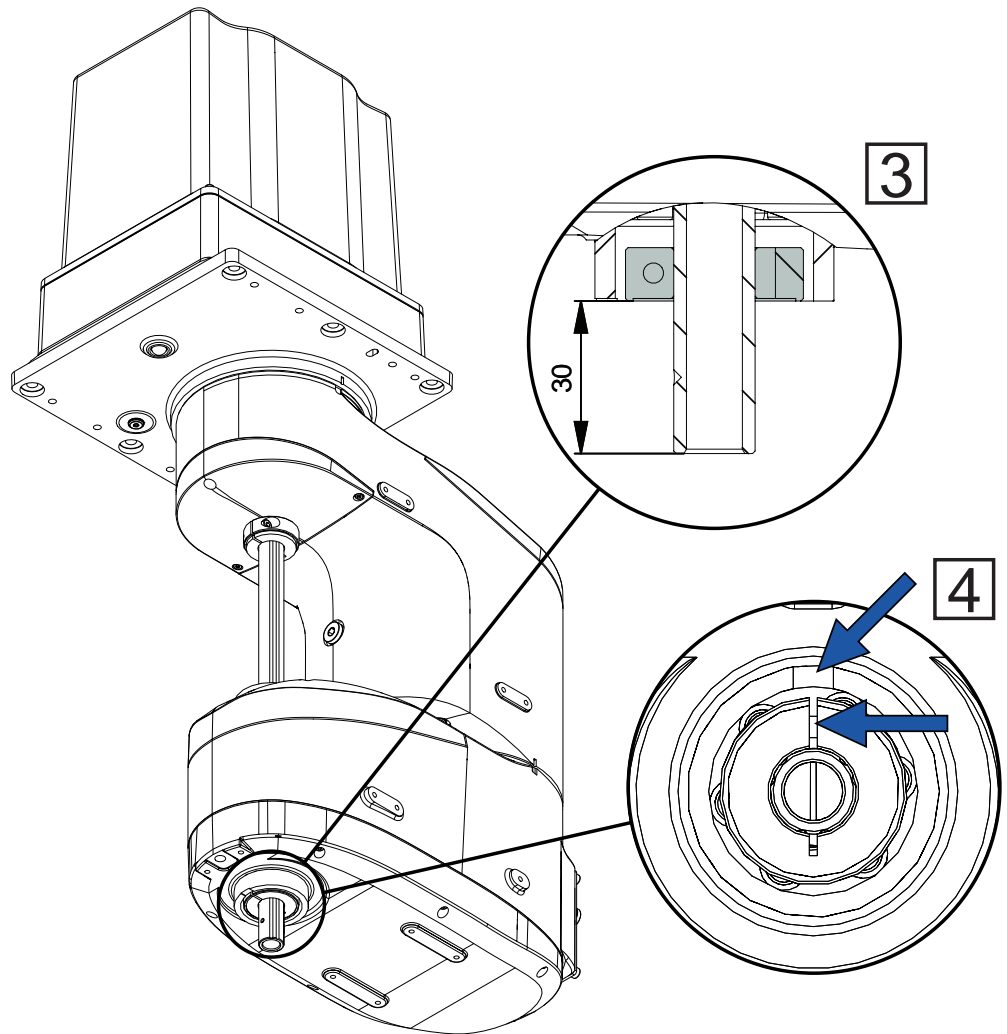

xx190000147

Continues on next page

6 Calibration

6.2.1 Synchronization marks and synchronization position for axes

Continued

Clean Room/ IP54

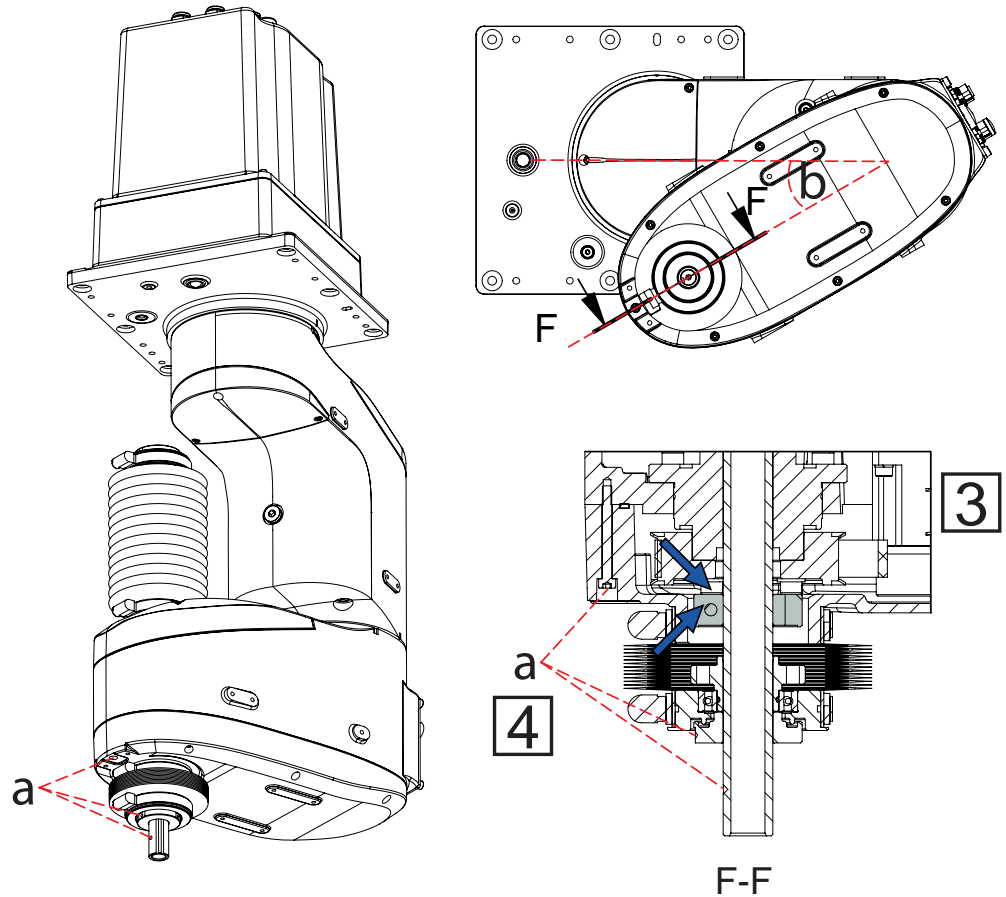

xx1900001711

a	The three points need to be aligned.
b	Axis 2 rotate -30° for IRB 910INV-3/0.35 Axis 2 rotate -25° for IRB 910INV-6/0.55

6.2.2 Calibration movement directions for all axes

Overview

When calibrating, the axis must consistently be run towards the calibration position in the same direction in order to avoid position errors caused by backlash in gears and so on. Positive directions are shown in the graphic below.

Calibration service routines will handle the calibration movements automatically and these might be different from the positive directions shown below.

Manual movement directions

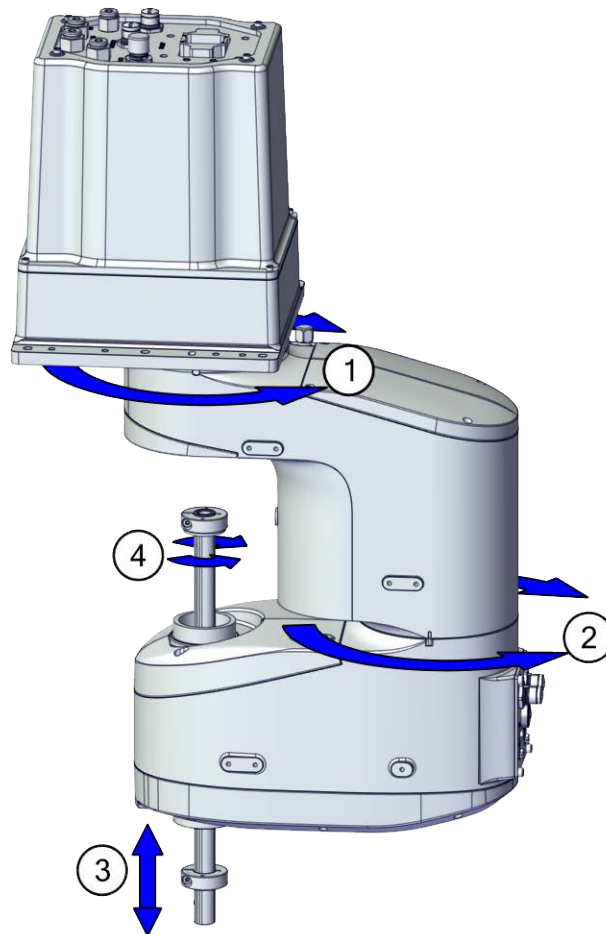

xx190000084

6 Calibration

6.3.1 Updating revolution counters on OmniCore robots

6.3 Updating revolution counters

6.3.1 Updating revolution counters on OmniCore robots

Introduction

This section describes how to do a rough calibration of each manipulator axis by updating the revolution counter for each axis, using the FlexPendant.

Coupled axes

When updating the revolution counters for a coupled axis, also the axis it is coupled to needs to be at its synchronization position for the update to be correct; i.e. axis 4 needs to be in synchronization position when updating axis 3.

With reversed coupled joints, the relationship is the opposite, i.e. axis 4 needs to be in synchronization position to update axis 3.

Coupled axes	IRB 910INV
Axis 4, 3	x

Step 1 - Manually running the manipulator to the synchronization position

Use this procedure to manually run the manipulator to the synchronization position.

	Action	Note
1	Select axis-by-axis motion mode.	
2	Jog the manipulator to align the synchronization marks.	See Synchronization marks and synchronization position for axes on page 775 .
3	When all axes are positioned, update the revolution counter.	Step 2 - Updating the revolution counter with the FlexPendant on page 795 .

Correct calibration position of axes 1 and 2

When jogging the manipulator to synchronization position, it is extremely important to make sure that axis 1 and 2 are positioned correctly. Axis 1 and 2 can be calibrated at the wrong turn, resulting in an incorrect manipulator calibration.

Continues on next page

Make sure axis 1 and 2 are positioned according to the cable harness status, not only according to the synchronization marks.

Axis 1 position

Use the following procedure to check and correct the axis 1 position.

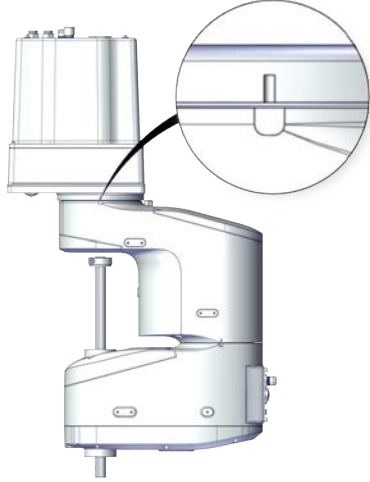
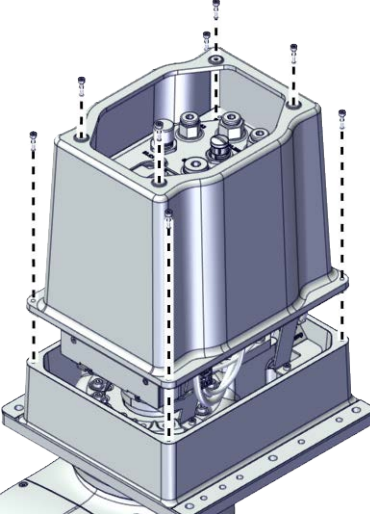
	Action	Note
1	Jog the manipulator to align the synchronization mark.	 <p>xx190000082</p>
2	Remove the base cover.	 <p>xx1800003547</p>

Continues on next page

6 Calibration

6.3.1 Updating revolution counters on OmniCore robots

Continued

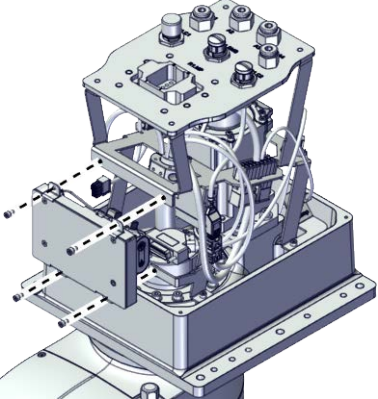
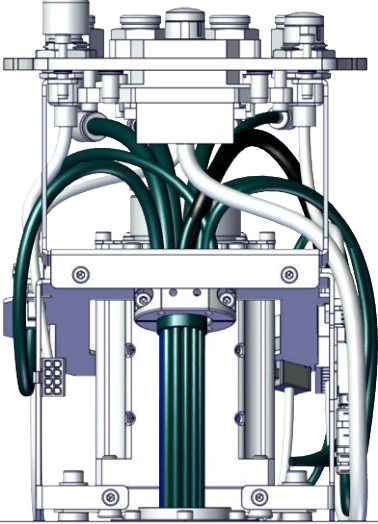
	Action	Note
3	<p>Remove the SMB assembly without disconnecting the connectors.</p> <p> Tip</p> <p>Do this step to see the cable status more clearly.</p>	 <p>xx1800003567</p>
4	<p>Inspect the cable harness status.</p> <p>The cable harness should be in vertical state without twisting as shown in the figure.</p>	 <p>xx1800003548</p>

Continues on next page

6.3.1 Updating revolution counters on OmniCore robots

Continued

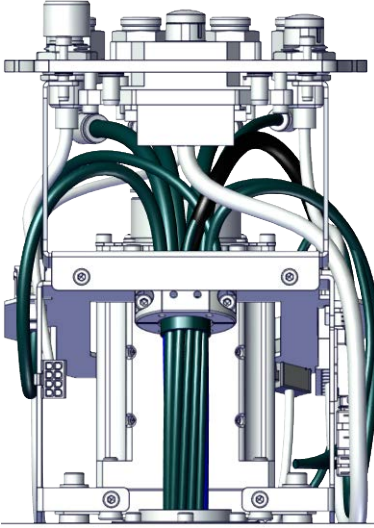
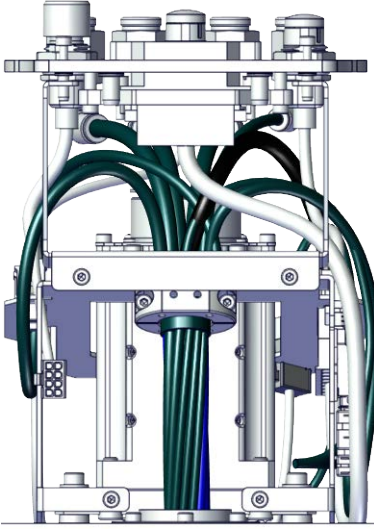
Action	Note
<p>Cable harness twisting towards left Jog the axis 1 anti-clockwise (with the operator facing the rear) until the cable harness is in vertical state.</p>	<p>90°</p>  <p>xx1800003549</p>
	<p>180°</p>  <p>xx1800003550</p>
	<p>270°</p>

Continues on next page

6 Calibration

6.3.1 Updating revolution counters on OmniCore robots

Continued

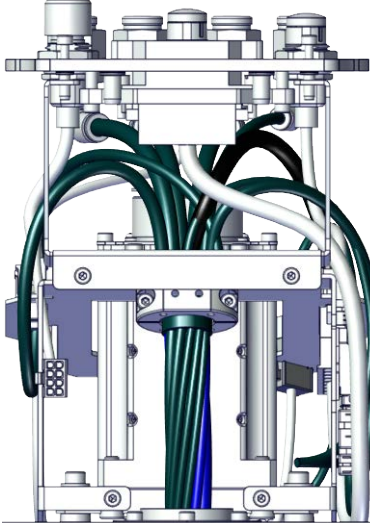
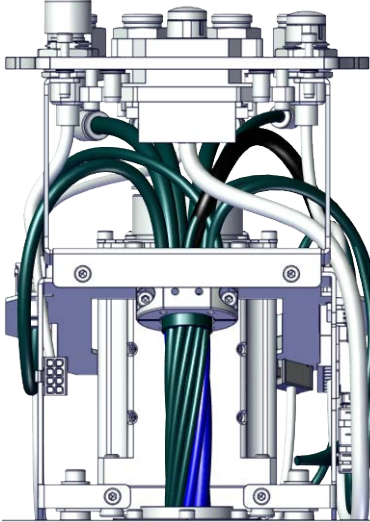
	Action	Note
		 <p data-bbox="1029 853 1134 869">xx1800003551</p> <p data-bbox="1029 909 1082 925">360°</p>  <p data-bbox="1029 1480 1134 1496">xx1800003552</p>

Continues on next page

6.3.1 Updating revolution counters on OmniCore robots

Continued

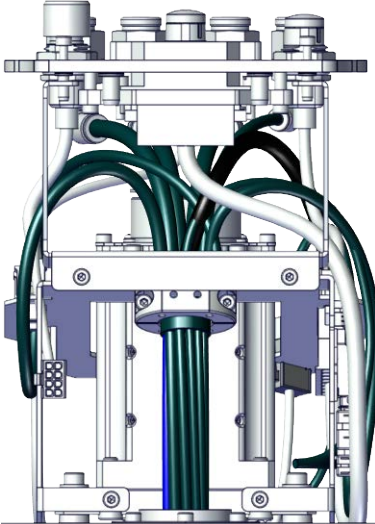
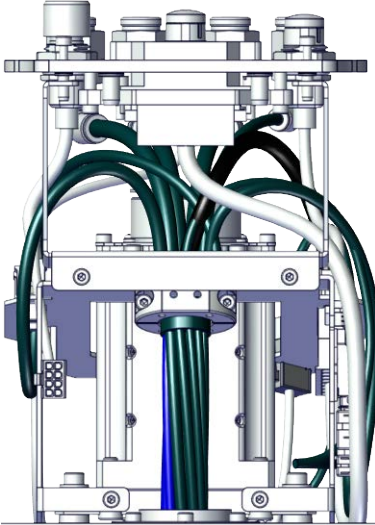
Action	Note
<p>Cable harness twisting towards right Jog the axis 1 clockwise (with the operator facing the rear) until the cable harness is in vertical state.</p>	<p>-90°</p>  <p>xx1800003553</p>
	<p>-180°</p>  <p>xx1800003554</p>
	<p>-270°</p>

Continues on next page

6 Calibration

6.3.1 Updating revolution counters on OmniCore robots

Continued

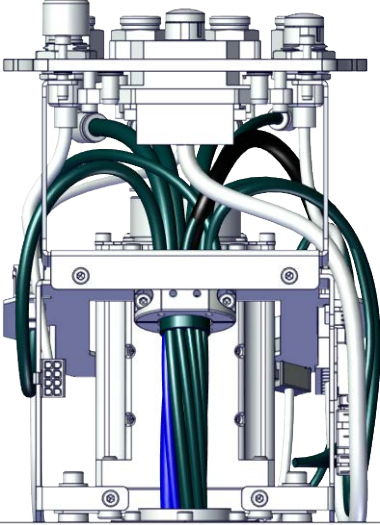
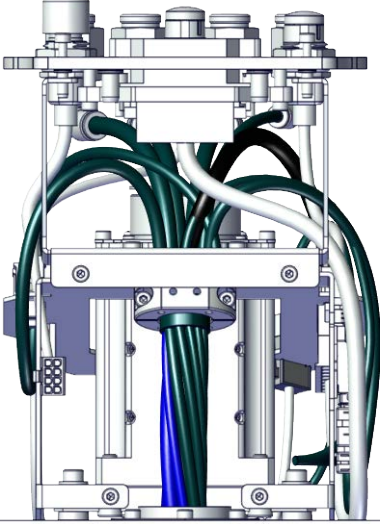
	Action	Note
		 <p data-bbox="1031 853 1136 869">xx1800003555</p> <p data-bbox="1031 909 1091 925">-360°</p>  <p data-bbox="1031 1480 1136 1496">xx1800003556</p>

Continues on next page

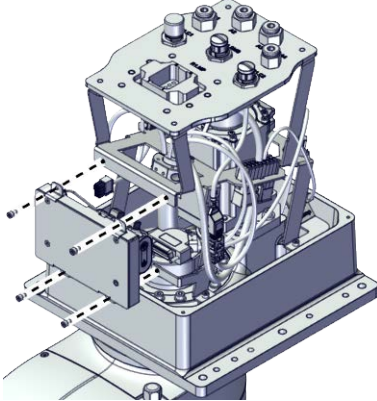
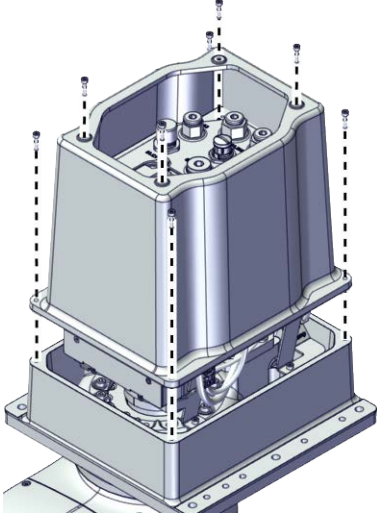
	Action	Note
5	Refit the SMB to the bracket.	<p>Screws: Hex socket head cap screw M3x5 12.9 Lafre 2C2B/FC6.9 (4 pcs) Tightening torque: 1.5 Nm</p>  <p>xx1800003567</p>
6	Refit the base cover.	<p>Screws: Hex socket head cap screw M3x12 12.9 Lafre 2C2B/FC6.9 (4 pcs) Hex socket head cap screw M3x8 12.9 Lafre 2C2B/FC6.9 (4 pcs) Tightening torque: 1.5 Nm</p>  <p>xx1800003547</p>

Continues on next page

6 Calibration

6.3.1 Updating revolution counters on OmniCore robots

Continued

Axis 2 position

Use the following procedure to check and correct the axis 2 position.

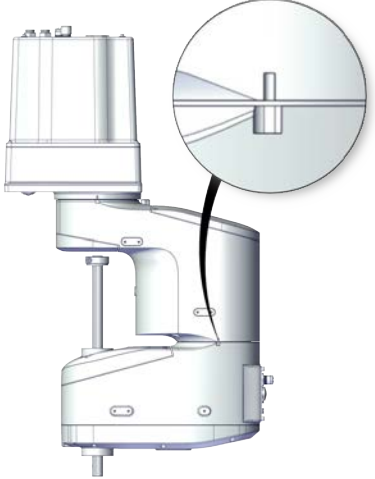
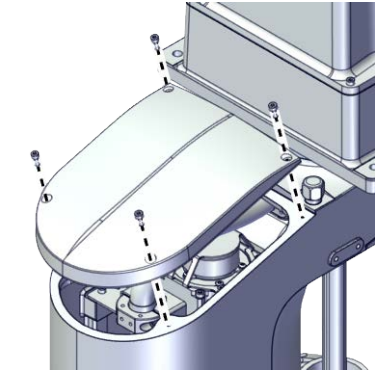
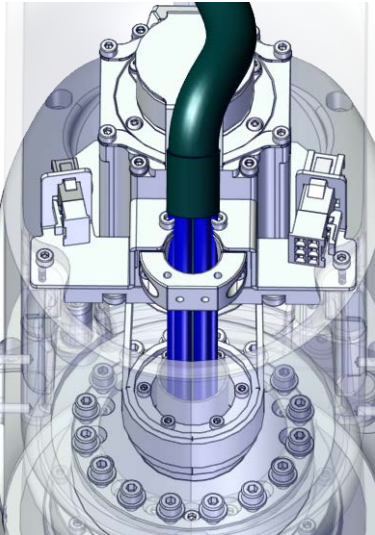
	Action	Note
1	Jog the manipulator to align the synchronization mark.	 xx190000083
2	Remove the inner arm casting cover.	 xx1800002873
3	Inspect the cable harness status. The cable harness should be in vertical state without twisting as shown in the figure.	 xx1800003557

Continues on next page

6.3.1 Updating revolution counters on OmniCore robots

Continued

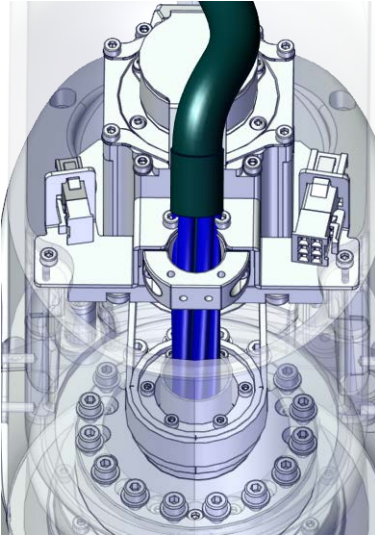
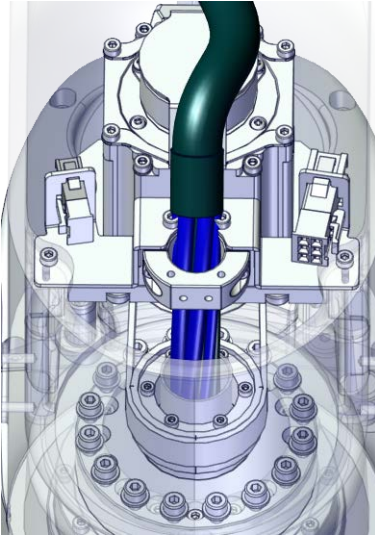
	Action	Note
	<p>Cable harness twisting towards left Jog the axis 2 anti-clockwise (with the operator facing the rear) until the cable harness is in vertical state.</p>	<p>90°</p>  <p>xx1800003558</p> <p>180°</p>  <p>xx1800003559</p> <p>270°</p>

Continues on next page

6 Calibration

6.3.1 Updating revolution counters on OmniCore robots

Continued

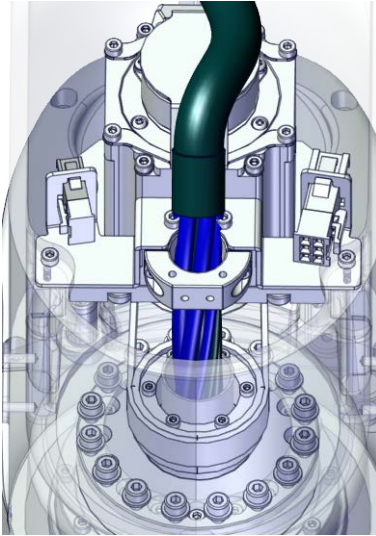
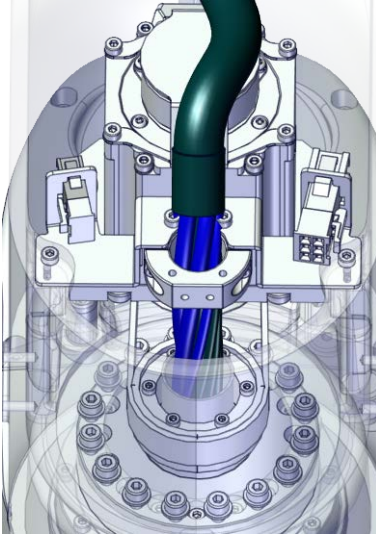
	Action	Note
		 <p data-bbox="1029 853 1136 875">xx1800003560</p> <p data-bbox="1029 909 1086 931">360°</p>  <p data-bbox="1029 1480 1136 1503">xx1800003561</p>

Continues on next page

6.3.1 Updating revolution counters on OmniCore robots

Continued

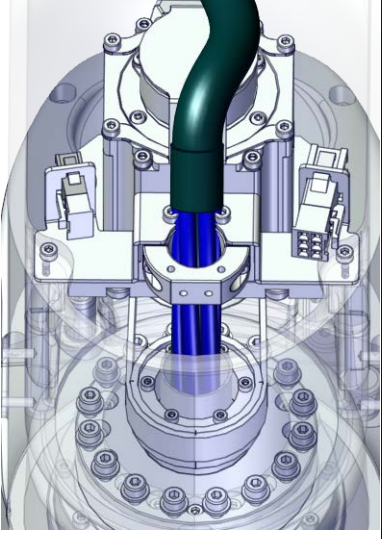
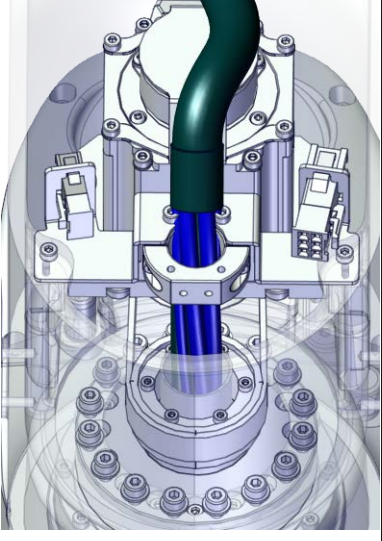
Action	Note
<p>Cable harness twisting towards right Jog the axis 2 clockwise (with the operator facing the rear) until the cable harness is in vertical state.</p>	<p>-90°</p>  <p>xx1800003562</p>
	<p>-180°</p>  <p>xx1800003563</p>
	<p>-270°</p>

Continues on next page

6 Calibration

6.3.1 Updating revolution counters on OmniCore robots

Continued

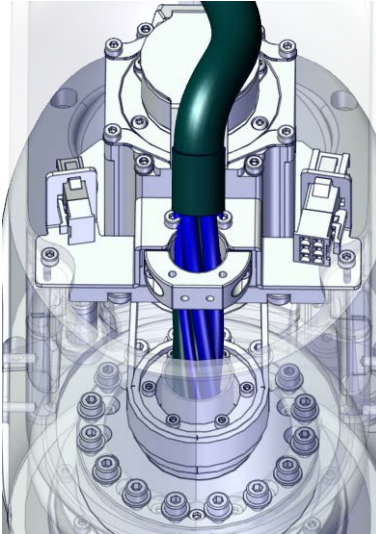
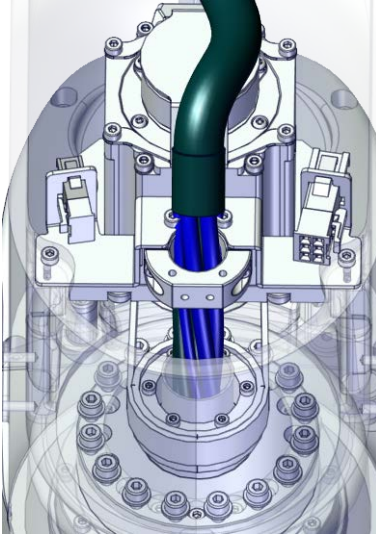
	Action	Note
		 <p data-bbox="1029 851 1141 873">xx1800003564</p> <p data-bbox="1029 907 1093 929">-360°</p>  <p data-bbox="1029 1478 1141 1500">xx1800003565</p>

Continues on next page

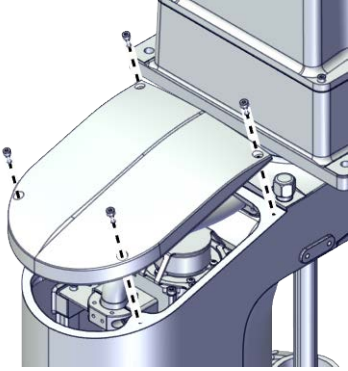
	Action	Note
4	Refit the inner arm casting cover.	<p>Screw: Hex socket head cap screw M3x8 12.9 Lafre 2C2B/FC6.9 (4 pcs) Tightening torque: 1.5 Nm</p>  <p>xx1800002873</p>

If the axis is rotated one or more turns from its calibration position before updating the revolution counter, the correct calibration position will be lost due to non-integer gear ratio.

At delivery the manipulator is in the correct position, do NOT rotate axis 1 or 2 at power up before the revolution counters are updated.

Continues on next page

6 Calibration

6.3.1 Updating revolution counters on OmniCore robots

Continued

Correct synchronization position of axes 3 and 4

When jogging the manipulator to synchronization position, it is extremely important to make sure that axes 3 and 4 are positioned correctly.



Note

At delivery the manipulator is in the correct position. Do NOT shift axis 3 or rotate axis 4 at power up before the revolution counters are updated.

If axis 4 is rotated one or more turns from its calibration position before updating the revolution counter, the correct calibration position will be lost due to non-integer gear ratio. This will further affect the calibration position of axis 3.

IP30

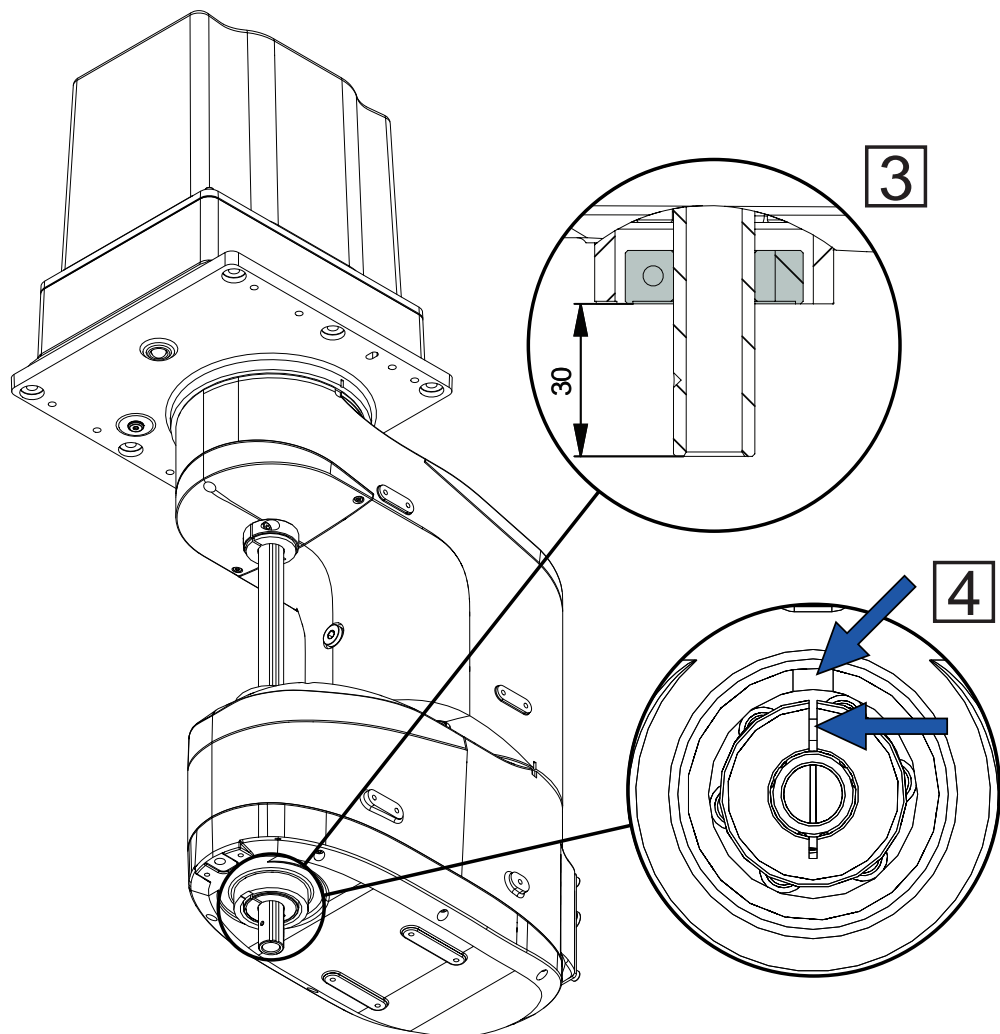

xx190000147

Continues on next page

Clean Room/ IP54

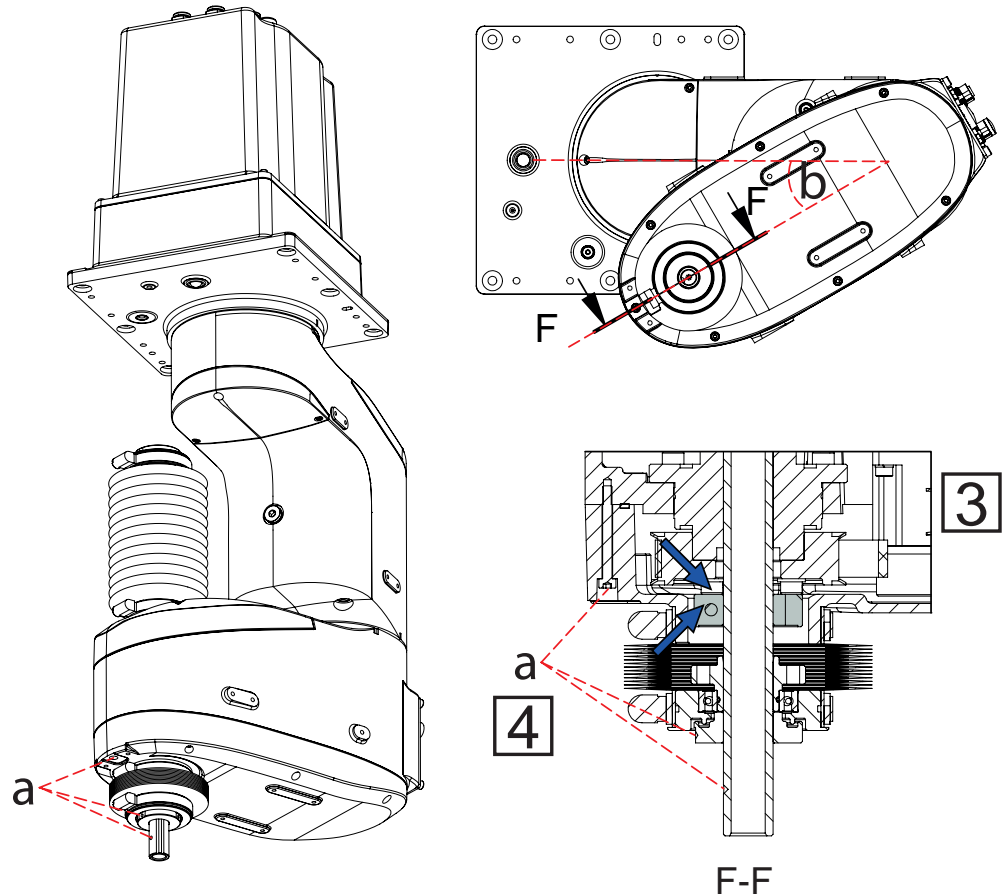

xx1900001711

a	The three points need to be aligned.
b	Axis 2 rotate -30° for IRB 910INV-3/0.35 Axis 2 rotate -25° for IRB 910INV-6/0.55

For robots with protection class IP54 and protection type Clean Room

Make sure the opening gap on the lower mechanical stopper is aligned with the notch on the outer arm cover, and the convex edge surface on the mechanical stopper is aligned with the lowest surface on the outer arm cover.

Step 2 - Updating the revolution counter with the FlexPendant



Note

Revolution counters of axes 3 and 4 must be updated together.

Use this procedure to update the revolution counter with the FlexPendant (OmniCore).





	Action
1	On the start screen, tap Calibrate .

Continues on next page

6 Calibration

6.3.1 Updating revolution counters on OmniCore robots

Continued

	Action
2	<p>Select Calibration from the menu. The Mechanical Units page displays a list of available mechanical units.</p> <p> Note</p> <p>This step is required only if you are not already in the Mechanical Unit page when you open Calibrate.</p> <p> Note</p> <p>The Mechanical Unit page is displayed only if there are more than one mechanical unit available. Otherwise, the calibration summary page for the available mechanical unit is displayed.</p>
3	Select the mechanical unit for which revolution counter need to be updated.
4	The calibration summary page for the selected mechanical unit is displayed. Calibration method used at factory for each axis is shown, as well as calibration method used during last field calibration.
5	Tap Calibration Methods on the right pane. The calibration options are displayed.
6	Tap Revolution Counters .
7	<p>In the Selection column select the axes for which revolution counters need to be updated.</p> <p> Note</p> <p>A warning is displayed prompting you to check the cable harness status before proceeding with the revolution counter update for axes 1 and 2. See Correct calibration position of axes 1 and 2 on page 780.</p>
8	<p>Tap Update. A dialog box is displayed, warning that the updating operation cannot be undone:</p> <ul style="list-style-type: none">• Tap Update to proceed with updating the revolution counters.• Tap Cancel to cancel updating the revolution counters. <p>Tapping Update and a confirmation window is displayed.</p>
9	<p>Tap OK. The revolution counter for the selected axes is updated.</p>
10	<p> CAUTION</p> <p>If a revolution counter is incorrectly updated, it will cause incorrect manipulator positioning, which in turn may cause damage or injury! Check the synchronization position very carefully after each update. See Checking the synchronization position on page 820.</p>

6.4 Calibrating with Axis Calibration method

6.4.1 Description of Axis Calibration

Instructions for Axis Calibration procedure given on the FlexPendant

The actual instructions of how to perform the calibration procedure and what to do at each step is given on the FlexPendant. You will be guided through the calibration procedure, step by step.

This manual contains a brief description of the method, additional information to the information given on the FlexPendant, article number for the tools and images of where to fit the calibration tools on the robot.

Overview of the Axis Calibration procedure

The Axis Calibration procedure applies to axes 1 and 2, and is performed on one axis at the time. The robot axes are both manually and automatically moved into position, as instructed on the FlexPendant.

A fixed calibration pin/bushing is installed on each robot axis at delivery.

The Axis Calibration procedure described roughly:

- 1 A removable calibration tool is inserted by the operator into a calibration bushing on the axis chosen for calibration, according to instructions on the FlexPendant.



WARNING

Calibrating the robot with Axis Calibration requires special calibration tools from ABB. Using other pins in the calibration bushings may cause severe damage to the robot and/or personnel.



WARNING

The calibration tool must be fully inserted into the calibration bushing, until the steel spring ring snaps into place.

- 2 During the calibration procedure, RobotWare moves the robot axis chosen for calibration so that the calibration tools get into contact. RobotWare records values of the axis position and repeats the coming-in-contact procedure several times to get an exact value of the axis position.



WARNING

Risk of pinching! The contact force for large robots can be up to 150 kg. Keep a safe distance to the robot.

- 3 The axis position is stored in RobotWare with an active choice from the operator.

Continues on next page

6 Calibration

6.4.1 Description of Axis Calibration

Continued

Routines in the calibration procedure

The following routines are available in the Axis Calibration procedure, given at the beginning of the procedure on the FlexPendant.

Fine calibration routine

Choose this routine to calibrate the robot when there are no tools, process cabling or equipment fitted to the robot.

Reference calibration routine

Choose this routine to create reference values and to calibrate the robot when the robot is dressed with tools, process cabling or other equipment.



Note

When calibrating the robot with the reference calibration routine, the robot must be dressed with the same tools, process cabling and any other equipment as when the reference values were created.



Note

When using reference calibration with some tools, typically large or flexible tools, oscillations in the robot can cause issues leading to failure of the calibration.

If calibrating the robot with reference calibration there must be reference values created before repair is made to the robot, if values are not already available. Creating new values requires possibility to move the robot. The reference values contain positions of all axes, torque of axes and technical data about the tool installed. A benefit with reference calibration is that the current state of the robot is stored and not the state when the robot left the ABB factory. The reference value will be named according to tool name, date etc.

Follow the instructions given in the reference calibration routine on the FlexPendant to create reference values.

When reference calibration is performed, the robot is restored to the status given by the reference values.

Update revolution counters

Choose this routine to make a rough calibration of each manipulator axis by updating the revolution counter for each axis, using the FlexPendant.

Validation

In the mentioned routines, it is also possible to validate the calibration data.

Position of robot axes

The robot axes should be positioned close to 0 degrees before commencing the calibration program. The axis chosen for calibration is then automatically run by the calibration program to its exact calibration position during the calibration procedure.

It is possible to position some of the other axes in positions different from 0 degrees. Information about which axes are allowed to be jogged is given on the FlexPendant.

Continues on next page

These axes are marked with **Unrestricted** in the FlexPendant window. Also the following table shows the dependencies between the axes.

Requirements for axis positioning during calibration

Required position of axis	Axis to calibrate					
	Axis 1	Axis 2	Axis 3	Axis 4	Axis 5	Axis 6
Axis 1	-	*				
Axis 2	*	-				

-	Axis to be calibrated
*	Unrestricted. Axis is allowed to be jogged to other position than 0 degrees.
0	Axis must be put in position 0 degrees.

How to calibrate an inverted robot

The IRB 910INV is calibrated inverted in factory, prior to shipping. To recalibrate an inverted robot, use either fine calibration or reference calibration routine.

6 Calibration

6.4.2 Calibration tools for Axis Calibration

6.4.2 Calibration tools for Axis Calibration

Calibration tool set

The calibration tools used for Axis Calibration are designed to meet requirements for calibration performance, durability and safety in case of accidental damage.

The calibration tool will eventually break from fatigue after longer period of use and then needs to be replaced. There is no risk for bad calibrations as long as the calibration tool is in one piece.



WARNING

Calibrating the robot with Axis Calibration requires special calibration tools from ABB. Using other pins in the calibration bushings may cause severe damage to the robot and/or personnel.

Equipment, etc.	Article number	Note
Calibration tool box, Axis Calibration	3HAC074119-001	Delivered as a set of calibration tools. Required if Axis Calibration is the valid calibration method for the robot. ⁱ

- ⁱ The robot is calibrated by either manual calibration or Axis Calibration at ABB factory before delivery. Always use the same calibration method as used at the factory. Information about valid calibration method is found on the calibration label or in the calibration menu on the FlexPendant. If no data is found related to standard calibration, manual calibration is used as default.

Examining the calibration tool

Check prior to usage

Before using the calibration tool, make sure that the tube insert, the plastic protection and the steel spring ring are present.



WARNING

If any part is missing or damaged, the tool must be replaced immediately.

Continues on next page

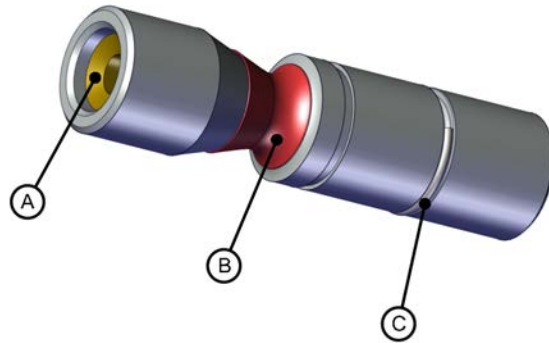

xx1500001914

A	Tube insert
B	Plastic protection
C	Steel spring ring

Periodic check of the calibration tool

If including the calibration tool in a local periodic check system, the following measures should be checked.

- Outer diameter within $\varnothing 12g4$ mm, $\varnothing 8g4$ mm or $\varnothing 6g5$ mm (depending on calibration tool size).
- Straightness within 0.005 mm.

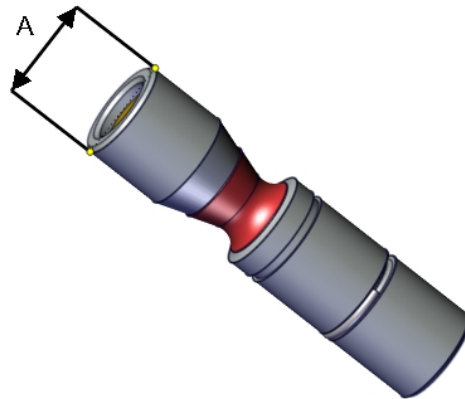

xx1500000951

A	Outer diameter
---	----------------

6 Calibration

6.4.3 Installation locations for the calibration tools

6.4.3 Installation locations for the calibration tools

Location of fixed calibration items

This section shows how the robot is equipped with items for installation of calibration tools for Axis Calibration (fixed calibration pins and/or bushings). Installed calibration tools are not shown.

A fixed calibration pin and a bushing for the movable calibration tool are located on each axis as follows.

If there is not enough space on an axis to install a fixed calibration pin, the axis is equipped with two bushings instead, for installation of two calibration tools when calibration is carried out. This is shown in the figure.

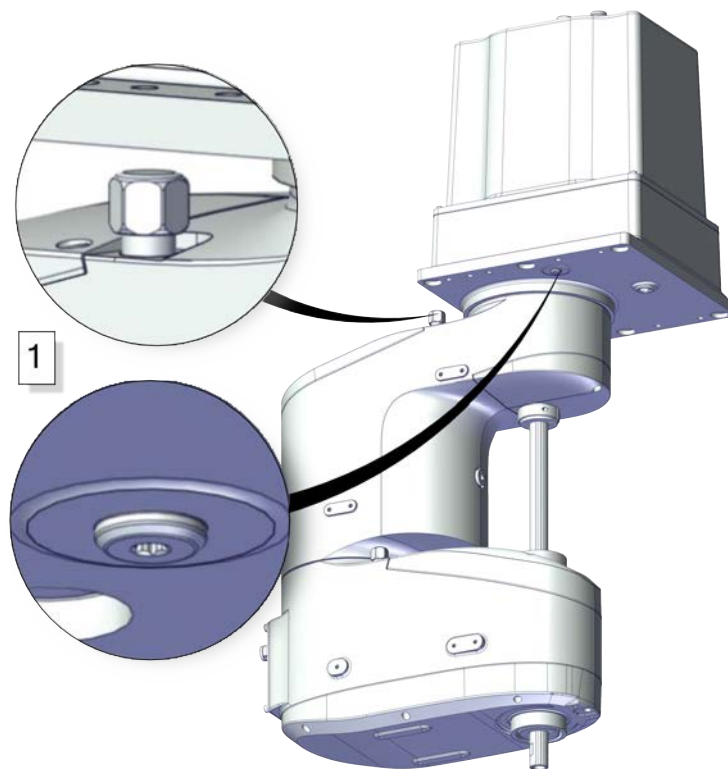

xx190000997

Continues on next page

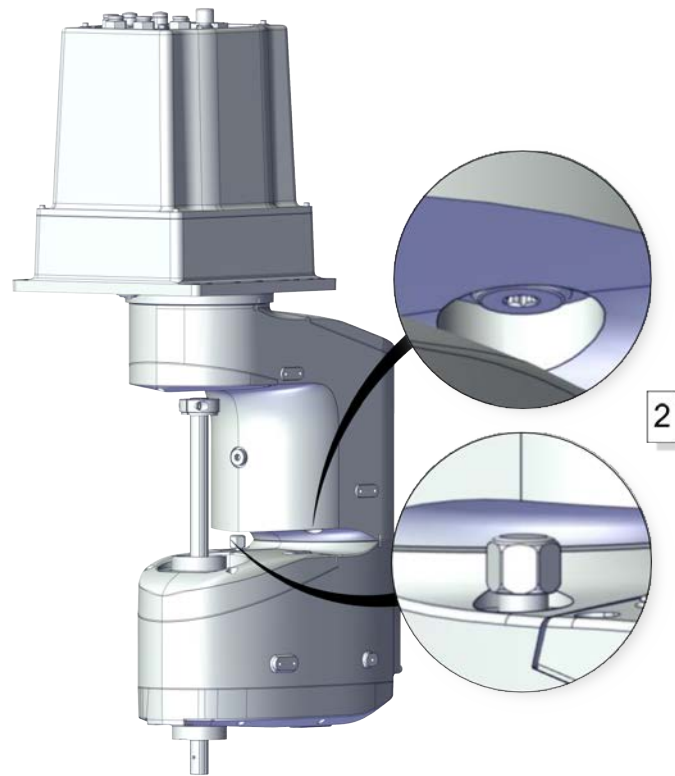

xx190000998

Spare parts

When calibration is not being performed, a protective cover and an o-ring should always be installed on the fixed calibration pin as well as a protective plug, included a sealing, in the bushing. Replace damaged parts with new.

Spare part	Article number	Note
Protective plug for bushing	3HAC059556-001	Replace if damaged or missing.
O-ring	3HAC061327-022	Replace if damaged or missing.
Calibration pin cover, 10 mm	3HAC056253-003	Replace if damaged or missing.

6 Calibration

6.4.4 Axis Calibration - Running the calibration procedure

6.4.4 Axis Calibration - Running the calibration procedure

Required tools

The calibration tools used for Axis Calibration are designed to meet requirements for calibration performance, durability and safety in case of accidental damage.



WARNING

Calibrating the robot with Axis Calibration requires special calibration tools from ABB. Using other pins in the calibration holes may cause severe damage to the robot and/or personnel.

Equipment, etc.	Article number	Note
Calibration tool box, Axis Calibration	3HAC074119-001	Delivered as a set of calibration tools. Required if Axis Calibration is the valid calibration method for the robot. ⁱ

- ⁱ The robot is calibrated by either manual calibration or Axis Calibration at ABB factory before delivery. Always use the same calibration method as used at the factory. Information about valid calibration method is found on the calibration label or in the calibration menu on the FlexPendant. If no data is found related to standard calibration, manual calibration is used as default.

Required consumables

Consumable	Article number	Note
Clean cloth	-	

Spare parts

Spare part	Article number	Note
Protective plug for bushing	3HAC059556-001	Replace if damaged or missing.
O-ring	3HAC061327-022	Replace if damaged or missing.
Calibration pin cover, 10 mm	3HAC056253-003	Replace if damaged or missing.

Overview of the calibration procedure on the FlexPendant

The actual instructions of how to perform the calibration procedure and what to do at each step is given on the FlexPendant. You will be guided through the calibration procedure, step by step.

Use the following list to learn about the calibration procedure before running the RobotWare program on the FlexPendant. It gives you a brief overview of the calibration procedure.

After the calibration method has been started on the FlexPendant, the following sequence will be run.

- 1 Choose calibration routine. The routines are described in [Routines in the calibration procedure on page 798](#).
- 2 Choose which axis/axes to calibrate.
- 3 The robot moves to synchronization position.
- 4 Validate the synchronization marks.

Continues on next page

6.4.4 Axis Calibration - Running the calibration procedure



Continued

- 5 The robot moves to preparation position.
- 6 Remove the protective cover from the fixed pin and the protection plug from the bushing, if any, and install the calibration tool.
- 7 The robot performs a measurement sequence by rotating the axis back and forth.
- 8 Remove the calibration tool and reinstall the protective cover on the fixed pin and the protection plug in the bushing, if any.
- 9 The robot moves to verify that the calibration tool is removed.
- 10 Choose whether to save the calibration data or not.

Calibration of the robot is not finished until the calibration data is saved, as last step of the calibration procedure.

Preparation prior to calibration

The calibration procedure is described in the FlexPendant while conducting it.

	Action	Note
1	 DANGER While conducting the calibration, the robot needs to be connected to power. Make sure that the robot's working area is empty, as the robot can make unpredictable movements.	
2	Wipe the calibration tool clean.  Note The calibration method is exact. Dust, dirt or color flakes will affect the calibration value.	Use a clean cloth.

Starting the calibration procedure

Use this procedure to start the Axis Calibration routine on the FlexPendant.

	Action	Note
1	Tap the calibration icon and enter the calibration main page.	
2	All mechanical units connected to the system are shown with their calibration status. Tap the mechanical unit in question.  Note For RobotWare 7, the mechanical unit page is displayed only if there is more than one mechanical unit available.	
3	The calibration method used at ABB factory for each axis is shown, as well as calibration method used for the robot during last field calibration.	The FlexPendant will give all information needed to proceed with Axis Calibration.

Continues on next page

6 Calibration

6.4.4 Axis Calibration - Running the calibration procedure

Continued

	Action	Note
4	Valid for RobotWare 7 Tap Calibration Methods on the right pane and then tap Calibration . The software will automatically call for the procedure for the valid calibration method.	
5	Follow the instructions given on the FlexPendant.	A brief overview of the sequence that will be run on the FlexPendant is given in Overview of the calibration procedure on the FlexPendant on page 804 .

Restarting an interrupted calibration procedure

If the Axis Calibration procedure is interrupted before the calibration is finished, the RobotWare program needs to be started again. Use this procedure to take required action.

Situation	Action
The three-position enabling device on the FlexPendant has been released during robot movement.	Press and hold the three-position enabling device and press Play .
The RobotWare program is terminated with PP to Main .	Remove the calibration tool, if it is installed, and restart the calibration procedure from the beginning. See Starting the calibration procedure . If the calibration tool is in contact the robot axis needs to be jogged in order to release the calibration tool. Jogging the axis in wrong direction will cause the calibration tool to break. Directions of axis movement is shown in Calibration movement directions for all axes on page 779

After calibration

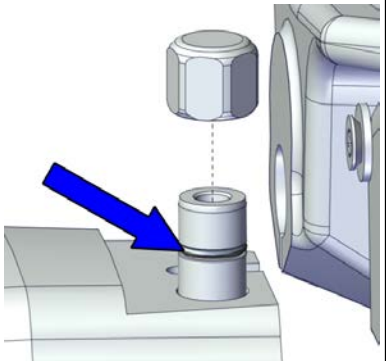
	Action	Note
1	Check the o-ring on the fixed calibration pin. Replace if damaged or missing.	 <p>xx1600002102</p> <p>O-ring: 3HAC061327-022 Calibration pin cover, 10 mm: 3HAC056253-003</p>
2	Reinstall the protective cover on the fixed calibration pin on each axis, directly after the axis has been calibrated. Replace the cover with new spare part, if missing or damaged.	

Continues on next page

6.4.4 Axis Calibration - Running the calibration procedure
Continued

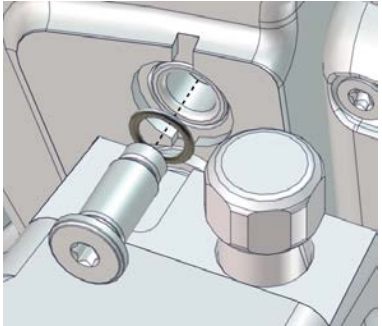
	Action	Note
3	<p>Reinstall the protective plug and sealing in the bushing on each axis, directly after the axis has been calibrated. Ensure that the sealing is not damaged.</p> <p>Replace the plug and the sealing with new spare part, if missing or damaged.</p>	 <p>xx1500000952</p> <p>Protective plug for bushing: 3HAC059556-001.</p>

6.4.5 Reference calibration

Brief introduction to Reference Calibration



Note

Only axes 1 and 2 of the IRB 910INV can be calibrated with the reference calibration routine.

Reference calibration is a faster method compared to Fine calibration, as it refers to a previously made calibration.

- 1 Create a backup of the current robot system.
- 2 Check that the active calibration offset values corresponds to the values on the silver label (on the lower arm or the base).
- 3 Jog the manipulator so that all axes are in zero position (ex use `MoveAbsJ` instruction). Check that all axis scales are aligned with calibration marks.
- 4 If the scales differ from calibration marks it might depend on wrong turns of the revolution counters. Make a marker line on the corresponding axis to be able to validate the result of the calibration. If more than one motor revolutions are wrong, the calibration will fail.
- 5 Use a verification position. This is especially recommended if all axes were not aligned with the synchronization marks (step 3). Reuse an existing position that is suitable and accurate so it can be used to validate the repair. Use a position where a deviation in axis calibration gives a big deviation in positioning. Note! Check the position after each repair in one axis.
- 6 Use Reference calibration to save reference values for all axes that is to be replaced. Make sure that the values are saved in RobotStudio or FTP program. The files are located in "Active system folder name/HOME/RefCalibFiles".
- 7 Perform the repair.
- 8 Make sure that the tooling and process equipment are the same as when creating the reference. Use Reference calibration to update the system with new calibration offset value for the repaired axis.
- 9 Check the position against the verification position (step 5).
- 10 Proceed with the repair of the next axis, if necessary, and repeat (step 8-9) for every axis.
- 11 Perform test run.
- 12 Update the label for resolver values with new calibration values.

Manual tuning of calibration offset

Manual tuning of calibration offset is normally not needed, but can be useful in some situations. The requirement to do manual tuning is that there is a known accurate position, that worked accurately before the repair (step 5, see [Brief introduction to Reference Calibration on page 808](#)).

6.5 Calibrating the robot

6.5.1 Calibration position

Calibration position

The table below specifies the axis positions.

Axis	IRB 910INV-3/0.35		IRB 910INV-6/0.55	
	IP30	IP54/Clean Room	IP30	IP54/Clean Room
3	5.5 mm	2 mm	8.3 mm	2 mm
4	0°	0°	0°	0°

6 Calibration

6.5.2 Calibrating axis 1 and axis 2

6.5.2 Calibrating axis 1 and axis 2

Calibrating axis 1 and axis 2

Axes 1 and 2 of the IRB 910INV are calibrated using the Axis Calibration method. See [Calibrating with Axis Calibration method on page 797](#).

6.5.3 Calibrating axis 3 and axis 4

Calibration position of axis 3 and axis 4

The figure shows axis 3 and axis 4 in calibration position. The axes 3 and 4 are calibrated together.

IP30

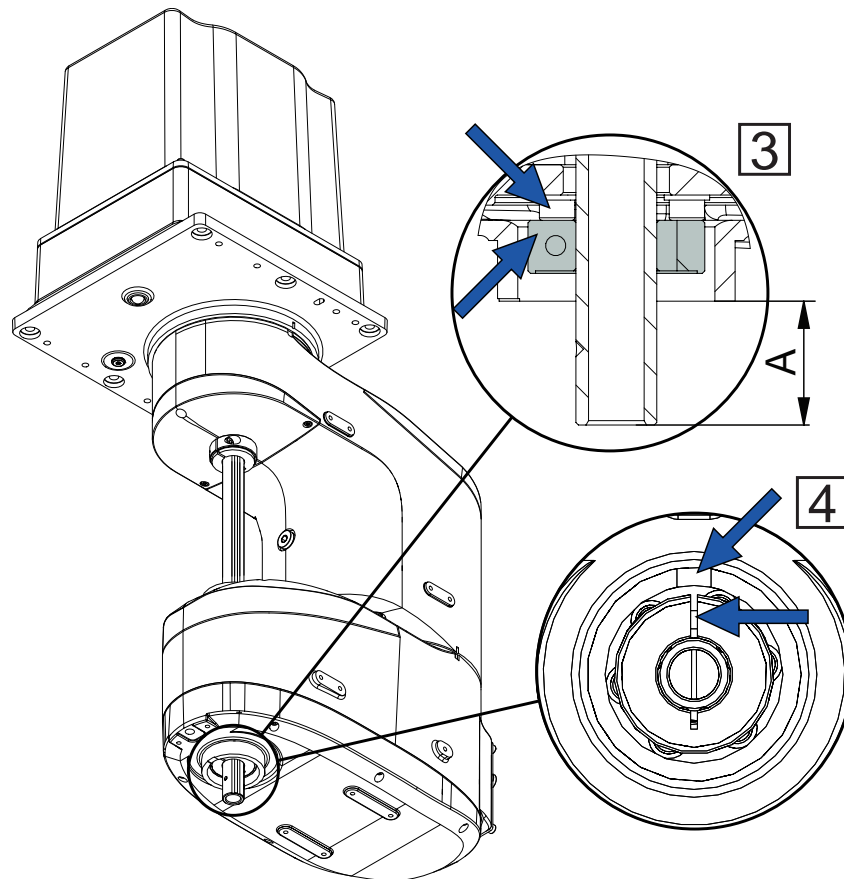

xx190000148

	IRB 910INV-3/0.35	IRB 910INV-6/0.55
A	24.5 mm	21.7 mm

Continues on next page

6 Calibration

6.5.3 Calibrating axis 3 and axis 4

Continued

Clean Room/ IP54

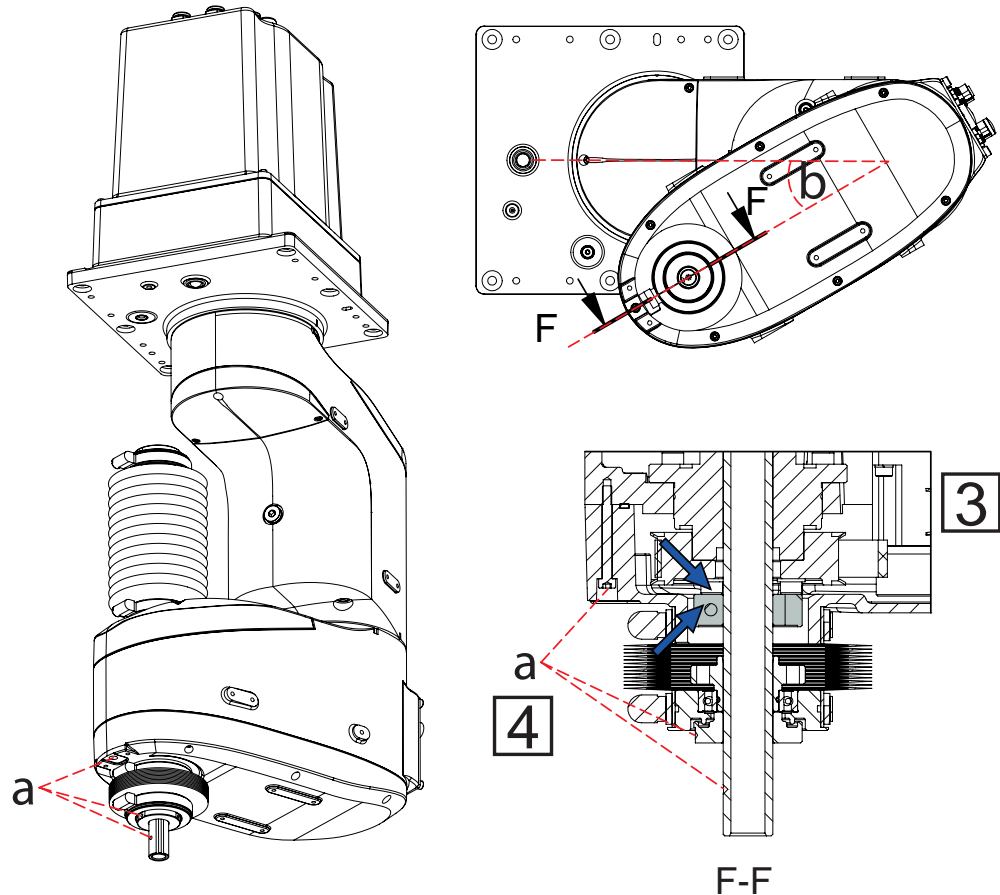

xx1900001711

a	The three points need to be aligned.
b	Axis 2 rotate -30° for IRB 910INV-3/0.35 Axis 2 rotate -25° for IRB 910INV-6/0.55



Note

For robots with protection class IP30

Do not mix up the calibration position with the synchronization position, which two are close to each other. See [Synchronization marks and synchronization position for axes on page 775](#) for the synchronization position for axis 3 and axis 4.

Required equipment

Axes 3 and 4 are calibrated together.

The axis-3 calibration is done by moving the ball screw spline unit so that the upper surface of the lower mechanical stopper and the screws on the lower pulley touch each other gently.

Continues on next page



The axis-4 calibration is done by rotating the ball screw spline unit so that the opening gap or the ball screw origin point on the lower mechanical stopper is aligned with the notch on the outer arm cover.

Required consumables

Equipment	Art. no.	Note
Cleaning agent	-	Isopropanol

Calibrating axis 3 and axis 4

Moving the robot to calibration position

	Action	Note
1	Jog axis 2 to the specified position: <ul style="list-style-type: none"> -30° for IRB 910INV-3/0.35 -25° for IRB 910INV-6/0.55 	
2	 DANGER Turn off all: <ul style="list-style-type: none"> electric power supply hydraulic pressure supply air pressure supply to the robot, before entering the robot working area.	
3	Remove the fitted extra equipment on the robot if it may cause a collision to the arm when push the ball screw to the calibration position.	
4	Turn on the electric power to the robot.	
5	 DANGER When releasing the holding brakes, the robot axes may move very quickly and sometimes in unexpected ways! Make sure the payload is disassembled or tooling is properly supported; otherwise, fast downward movements of axis 3 may cause severe hits.	

Continues on next page

6 Calibration

6.5.3 Calibrating axis 3 and axis 4

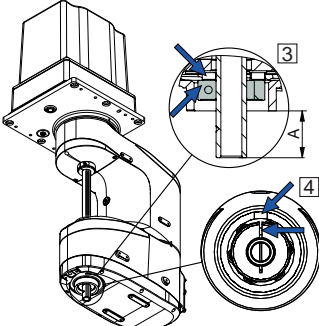
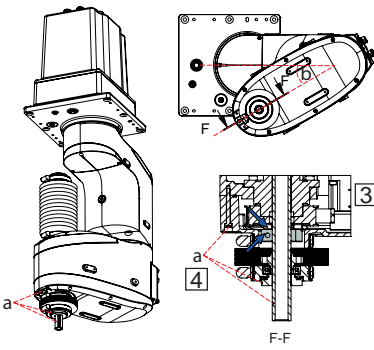

Continued

	Action	Note				
6	<p>Release the brakes and manually push axis 3 until the upper surface of the lower mechanical stopper touches the screws on the lower pulley gently. There should be no pressing force between them.</p> <p>When doing this, pay attention to robot pose in order to avoid arm collision.</p>	<p>How to release the brakes is detailed in Manually releasing the brakes on page 65.</p> <p>IP30</p>  <p>xx1900000148</p> <table border="1" data-bbox="1029 824 1404 943"> <thead> <tr> <th data-bbox="1029 824 1225 898">IRB 910INV-3/0.35</th> <th data-bbox="1225 824 1404 898">IRB 910INV-6/0.55</th> </tr> </thead> <tbody> <tr> <td data-bbox="1029 898 1225 943">A 24.5 mm</td> <td data-bbox="1225 898 1404 943">21.7 mm</td> </tr> </tbody> </table>	IRB 910INV-3/0.35	IRB 910INV-6/0.55	A 24.5 mm	21.7 mm
IRB 910INV-3/0.35	IRB 910INV-6/0.55					
A 24.5 mm	21.7 mm					
7	<p>Release the brakes (for IRB 910INV-6/0.55 only) and manually rotate axis 4 until the opening gap or the ball screw origin point on the lower mechanical stopper is aligned with the notch on the outer arm cover.</p> <p>When doing this, pay attention to robot pose in order to avoid arm collision.</p>	<p>Clean Room/ IP54</p>  <p>xx1900001711</p> <table border="1" data-bbox="1029 1388 1232 1675"> <tbody> <tr> <td data-bbox="1029 1388 1232 1489"> <p>a The three points need to be aligned.</p> </td> </tr> <tr> <td data-bbox="1029 1489 1232 1675"> <p>b Axis 2 rotate - 30° for IRB 910INV-3/0.35 Axis 2 rotate - 25° for IRB 910INV-6/0.55</p> </td> </tr> </tbody> </table>	<p>a The three points need to be aligned.</p>	<p>b Axis 2 rotate - 30° for IRB 910INV-3/0.35 Axis 2 rotate - 25° for IRB 910INV-6/0.55</p>		
<p>a The three points need to be aligned.</p>						
<p>b Axis 2 rotate - 30° for IRB 910INV-3/0.35 Axis 2 rotate - 25° for IRB 910INV-6/0.55</p>						
8	<p>When the axes are in position, release the brake release button to activate the brakes again.</p>					

Performing the fine calibration procedure

	Action	Note
1	On the start screen, tap Calibrate .	

Continues on next page

	Action	Note
2	<p>Select Calibration from the menu.</p> <p>The Mechanical Units page displays a list of available mechanical units.</p> <p> Note</p> <p>This step is required only if you are not already in the Mechanical Unit page when you open Calibrate.</p> <p> Note</p> <p>The Mechanical Unit page is displayed only if there are more than one mechanical unit available. Otherwise, the calibration summary page for the available mechanical unit is displayed.</p>	
3	<p>Select the unit that needs to be calibrated from the Mechanical Unit list.</p> <p>The calibration summary for the selected mechanical unit is displayed.</p>	
4	On the right pane tap Calibration Methods .	
5	<p>Tap Calibration Parameters.</p> <p>The calibration parameters are displayed.</p>	
6	<p>Tap Fine Calibration.</p> <p>A dialog box is displayed, urging you to use external equipment to perform the actual calibration. Make sure all necessary calibration equipment is fitted for the axis to be calibrated.</p> <p>A warning that performing fine calibration can change programmed robot positions is also displayed:</p> <ul style="list-style-type: none"> • Tap Yes to proceed. • Tap No to cancel. 	
7	Select the check-box for the current axis/axes to be calibrated.	
8	<p>Tap Calibrate.</p> <p>A dialog box is displayed, warning that calibration of the selected axes will be changed, which cannot be undone:</p> <ul style="list-style-type: none"> • Tap Calibrate to proceed. • Tap Cancel to cancel. <p>Tapping Calibrate results in briefly displaying a dialog box, announcing that the calibration process has started.</p> <p>The axis is calibrated and the system returns to the list of available mechanical units.</p>	
9	<p>Tap OK.</p> <p>The fine calibration process is complete.</p>	

Continues on next page

6 Calibration

6.5.3 Calibrating axis 3 and axis 4

Continued

Checking and finalizing the calibration

	Action	Note
1	 DANGER Always remember to remove the calibration tools from the robot before jogging axes to zero position during calibration.	
2	Release the brakes and manually rotate the axis to apart the calibration pins from each other. This is done to avoid damage on the pins if incorrect operation should occur during next step of jogging.	
3	Jog axes 3 and 4 to zero degree using the Flex-Pendant.	

Continues on next page

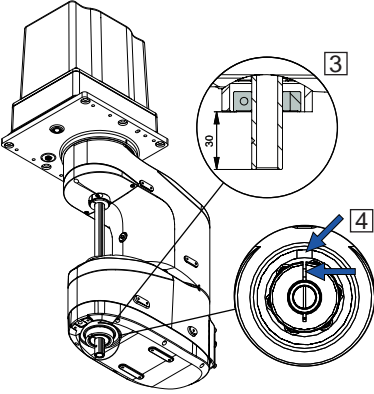
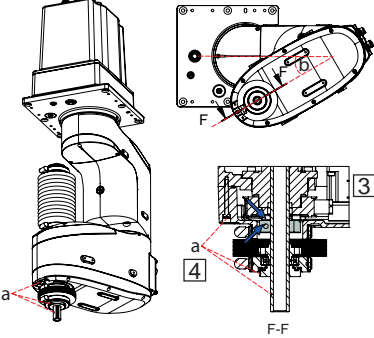
	Action	Note				
4	<p>Check that the synchronization marks on axes 3 and 4 are aligned with each other.</p> <p>Are they aligned within the tolerances?</p> <ul style="list-style-type: none"> • If yes, the calibration is verified OK. • If no, redo the fine calibration procedure. 	<p>IP30</p>  <p>xx1900000147</p> <p>Clean Room/ IP54</p>  <p>xx19000001711</p> <table border="1" data-bbox="1061 1220 1260 1512"> <tr> <td data-bbox="1061 1220 1085 1254">a</td> <td data-bbox="1085 1220 1260 1321">The three points need to be aligned.</td> </tr> <tr> <td data-bbox="1061 1332 1085 1366">b</td> <td data-bbox="1085 1332 1260 1512"> Axis 2 rotate - 30° for IRB 910INV-3/0.35 Axis 2 rotate - 25° for IRB 910INV-6/0.55 </td> </tr> </table>	a	The three points need to be aligned.	b	Axis 2 rotate - 30° for IRB 910INV-3/0.35 Axis 2 rotate - 25° for IRB 910INV-6/0.55
a	The three points need to be aligned.					
b	Axis 2 rotate - 30° for IRB 910INV-3/0.35 Axis 2 rotate - 25° for IRB 910INV-6/0.55					
5	Update the revolution counters of axes 3 and 4.	See Updating revolution counters on page 780 .				

After calibration

	Action	Note
1	Write down the new system parameters on a new label and stick on top of the calibration label on the robot.	

6 Calibration

6.5.3 Calibrating axis 3 and axis 4

Continued



Note

The calibration status of axis 3 may be changed to **Not updated** after a system reinstallation or warm restart. In this case, update the revolution counters for axis 3 and axis 4 (axis 4 is coupled with axis 3). See [Updating revolution counters on page 780](#).

6.6 Verifying the calibration

Introduction

Always verify the results after calibrating *any* robot axis to verify that all calibration positions are correct.

Verifying the calibration

Use this procedure to verify the calibration result.

	Action	Note
1	Run the calibration home position program twice. Do not change the position of the robot axes after running the program!	See Checking the synchronization position on page 820 .
2	Adjust the <i>synchronization marks</i> when the calibration is done, if necessary.	This is detailed in section Synchronization marks and synchronization position for axes on page 775 .
3	Write down the values on a new label and stick it on top of the calibration label. The label is located on the base.	

6 Calibration

6.7 Checking the synchronization position

6.7 Checking the synchronization position

Introduction

Check the synchronization position of the robot before beginning any programming of the robot system. This may be done:

- Using a `MoveAbsJ` instruction with argument zero on all axes.
- Using the **Jog** window on the FlexPendant.

Using a `MoveAbsJ` instruction

Use this procedure to create a program that runs all the robot axes to their synchronization position.

	Action	Note
1	Tap Code .	
2	Create a new program.	
3	Use MoveAbsJ in the Add Instruction menu.	
4	Create the following program: <pre>MoveAbsJ [[0,0,0,0,0,0], [9E9,9E9,9E9,9E9,9E9,9E9]] \NoEOffs, v1000, fine, tool0</pre>	
5	Run the program in manual mode.	
6	Check that the synchronization marks for the axes align correctly. If they do not, update the revolution counters.	See Synchronization marks and synchronization position for axes on page 775 and Updating revolution counters on page 780 .

Using the jogging window

Use this procedure to jog the robot to the synchronization position of all axes.

	Action	Note
1	Tap Jog .	
2	From the Mechanical unit list select a mechanical unit.	
3	From the Motion mode section, select an axis-set that need to be jogged. For example, to jog axis 2, select the axis set Axis 1-3 .	
4	Follow the screen instruction on joystick movements to understand the direction of the axis that you want to move and move the joystick.	
5	Manually run the robots axes to a position where the axis position value read on the FlexPendant, is equal to zero.	
6	Check that the synchronization marks for the axes align correctly. If they do not, update the revolution counters.	See Synchronization marks and synchronization position for axes on page 775 and Updating revolution counters on page 780 .

7 Troubleshooting

7.1 Introduction to troubleshooting

Introduction

The product manual and the circuit diagram contains information that can be good when troubleshooting.

For OmniCore, all event logs from the software can be seen on the FlexPendant, or in *Technical reference manual - Event logs for RobotWare 7*.

Make sure to read through the section [Safety on page 15](#) before starting.

Troubleshooting strategies

- 1 Isolate the fault to pinpoint the cause of the problem from consequential problems.
- 2 Divide the fault chain in two.
- 3 Check communication parameters and cables.
- 4 Check that the software version is compatible with the hardware.

Work systematically

- 1 Take a look around to make sure that all screws, connectors, and cables are secured, and that the robot and other parts are clean, not damaged, and correctly fitted.
- 2 Replace one thing at a time.
- 3 Do not replace units randomly.
- 4 Make sure that there are no loose screws, turnings, or other unexpected parts remaining after work has been performed.
- 5 When the work is completed, verify that the safety functions are working as intended.

Keep a track of history

- Make a historical fault log to keep track of problems over time.
- Consult those working with the robot when the problem occurred.

Basic scenarios

What to look for during troubleshooting depends on when the fault occurred. Was the robot recently installed or was it recently repaired? The following table gives hints on what to look for in specific situations.

The robot has recently been installed	Check: <ul style="list-style-type: none"> • the configuration files • connectors • options and their configuration • changes in the robot working space/movements.
---------------------------------------	--

Continues on next page

7 Troubleshooting

7.1 Introduction to troubleshooting

Continued

The robot has recently been repaired	Check: <ul style="list-style-type: none">• all connections to the replaced part• power supplies• that the correct part has been fitted• the last repair documents.
The robot recently had a software upgrade	Check: <ul style="list-style-type: none">• software versions• compatibilities between hardware and software• options and their configuration
The robot has recently been moved from one site to another (an already working robot)	Check: <ul style="list-style-type: none">• connections• software versions

7.2 Oil and grease stains on motors and gearboxes

Description

The area surrounding the motor, gearbox or seal lip shows signs of oil leaks. This can be at the base, closest to the mating surface, at the furthest end of the motor at the resolver, or around the joints of the covers (closest to the edge) on the robot surface.

Consequences

Besides the dirty appearance, in most cases there are no serious consequences if the leaked amount of oil is very small.

Possible causes

The symptom can be caused by:

- Leakage of rust preventives or mounting grease. This should be wiped off.
- Leaking sealing between gearbox and motor.
- Gearbox overfilled with oil.
- Gearbox oil too hot.

Recommended actions

The following actions are recommended:

	Action	Information
1	 CAUTION Allow hot parts to cool down.	
2	Wipe off the oil or grease, see Cleaning the IRB 910INV on page 97 . Monitor the robot over time to see if new oil or grease occurs.	If the oil spill is small, this step is sufficient.
3	Too hot gearbox oil may be caused by: <ul style="list-style-type: none"> • Incorrect oil quality or level. • The robot work cycle runs a specific axis too hard. Investigate whether it is possible to program small "cooling periods" into the application. • Overpressure created inside gearbox. 	Robots performing certain, extremely heavy duty work cycles may be fitted with vented oil plugs. These are not fitted to normal duty robots, but can be purchased from your local ABB representative.
4	Inspect all sealings and gaskets between motor and gearbox. Replace broken parts.	

7 Troubleshooting

7.3 Mechanical noise or dissonance

7.3 Mechanical noise or dissonance

Description

Mechanical noise or dissonance that has not been observed before can indicate problems in bearings, motors, gearboxes, or similar. Be observant of changes over time.

A faulty bearing often emits scraping, grinding, or clicking noises shortly before failing.

A humming resonance sound can occur without being an error. Mechanical resonance sound is a physical phenomenon in mechanical structures. It has no impact on product performance or lifetime. Adjusting the robot movement speed out of the range that causes the resonance will eliminate the sound.

Consequences

Failing bearings cause the path accuracy to become inconsistent, and in severe cases, the joint can seize completely.

Possible causes

The symptom can be caused by:

- Worn bearings.
- Contaminations have entered the bearing grooves.
- Loss of lubrication in bearings.
- Loss of lubrication in ball screw.
- Loose heat sinks, fans, or metal parts.

If the noise is emitted from a gearbox, the following can also apply:

- Overheating.

Recommended actions

The following actions are recommended:

	Action	Information
1	 CAUTION Allow hot parts to cool down.	
2	Verify that the service is done according to the maintenance schedule.	
3	If a bearing is emitting the noise, determine which one and make sure that it has sufficient lubrication.	
4	If possible, disassemble the joint and measure the clearance.	
5	Bearings inside motors are not to be replaced individually, but the complete motor is replaced.	
6	Make sure the bearings are fitted correctly.	

Continues on next page

	Action	Information
7	Tighten the screws if a heat sink, fan, or metal sheet is loose.	

7 Troubleshooting

7.4 Manipulator collapses on power down

7.4 Manipulator collapses on power down

Description

The manipulator is able to work correctly while Motors ON is active, but when Motors OFF is active, one or more axes drops or collapses under its own weight. The holding brakes (normally one in each motor), is not able to hold the weight of the manipulator arm.

Consequences

For a heavy robot, the collapse can cause severe injury to personnel working in the area or severe damage to the robot and/or surrounding equipment.
For a small robot, the collapse can cause injury to personnel working close to the robot or damage to the robot and/or surrounding equipment.

Possible causes

The symptom can be caused by:

- Faulty brake.
 - Faulty power supply to the brake.
-

Recommended actions

The following actions are recommended:

	Action	Information
1	Determine which motor(s) causes the robot to collapse.	
2	Check the brake power supply to the collapsing motor during the Motors OFF state.	See the circuit diagram.
3	Remove the resolver or resolver cover of the motor to see if there are any signs of oil leaks.	If found faulty, the motor must be replaced as a complete unit.
4	Remove the motor from the gearbox to inspect it from the drive side.	If found faulty, the motor must be replaced as a complete unit.

7.5 Motor temperature too high

Description

The robot stops and the motor temperature for joint arg is too high.

Consequences

It is not possible to continue until the motor has cooled down. The system goes to Motors Off.

Possible causes

The symptom can be caused by:

- The values for payload and arm load are not consistent with the actual ones.
- The value for ambient temperature setting in the controller is not consistent with the actual operating temperature environment.
- The user program may contain too much high acceleration and deceleration of the joint.
- Gravity torque or external forces for the joint can also be too high.

Recommended actions

The following actions are recommended:

	Action	Information
1	 CAUTION Allow hot parts to cool down.	
2	Verify that the values for payload and arm load are set correctly.	
3	Verify that the value for ambient temperature setting in the controller is consistent with the actual operating temperature environment.	
4	Rewrite the user program to reduce the motor utilization.	The ways could be but not limited to optimizing robot movement cycle, adjusting acc, dec as well as external force, adding wait time, and introducing alternative path/RAPID, etc.

This page is intentionally left blank

8 Decommissioning

8.1 Introduction to decommissioning

Introduction

This section contains information to consider when taking a product, robot or controller, out of operation.

It deals with how to handle potentially dangerous components and potentially hazardous materials.



Note

The decommissioning process shall be preceded by a risk assessment.

Disposal of materials used in the robot

All used grease/oils and dead batteries **must** be disposed of in accordance with the current legislation of the country in which the robot and the control unit are installed.

If the robot or the control unit is partially or completely disposed of, the various parts **must** be grouped together according to their nature (which is all iron together and all plastic together), and disposed of accordingly. These parts **must** also be disposed of in accordance with the current legislation of the country in which the robot and control unit are installed.

See also [Environmental information on page 830](#).

Transportation

Prepare the robot or parts before transport, this to avoid hazards.

8 Decommissioning

8.2 Environmental information

8.2 Environmental information

Introduction

ABB robots contain components in different materials. During decommissioning, all materials should be dismantled, recycled, or reused responsibly, according to the relevant laws and industrial standards. Robots or parts that can be reused or upcycled helps to reduce the usage of natural resources.

Symbol

The following symbol indicates that the product must not be disposed of as common garbage. Handle each product according to local regulations for the respective content (see table below).

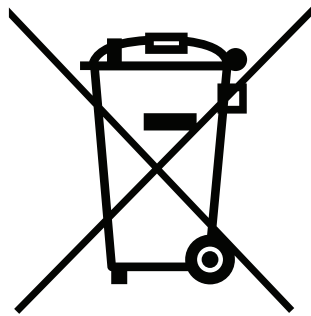

xx1800000058

Materials used in the product

The table specifies some of the materials in the product and their respective use throughout the product.

Dispose components properly according to local regulations to prevent health or environmental hazards.

Material	Example application
Aluminium	Casting, machining parts, etc
Batteries, Lithium	Battery pack
Neodymium	Motors
Oil, grease	Drive units, ball screw spline unit
Plastic/rubber	Mechanical stop rubber, connectors, belts, bellow, and etc
Stainless steel	Brackets
Steel	Drive units, ball screw spline unit, screws, and etc

Continues on next page

China RoHS symbol

The following symbol shows the information to hazardous substances and the environmental protection use period of IRB 910INV according to "Management Methods for the Restriction of the Use of Hazardous Substances in Electrical and Electronic Products (SJ/T 11364-2014)".



xx190000803

Green symbol with "e" in it: The product does not contain any hazardous substances exceeding concentration limits and is a green environmentally friendly product which can be recycled.

Oil and grease

Where possible, arrange for oil and grease to be recycled. Dispose of via an authorized person/contractor in accordance with local regulations. Do not dispose of oil and grease near lakes, ponds, ditches, down drains, or onto soil. Incineration must be carried out under controlled conditions in accordance with local regulations.

Also note that:

- Spills can form a film on water surfaces causing damage to organisms. Oxygen transfer could also be impaired.
- Spillage can penetrate the soil causing ground water contamination.

8 Decommissioning

8.3 Scrapping of robot

8.3 Scrapping of robot



Note

The decommissioning process shall be preceded by a risk assessment.

Important when scrapping the robot



DANGER

The risk assessment should consider hazards arising in the decommissioning, such as, but not limited to:

- Always remove all batteries. If a battery is exposed to heat, for example from a blow torch, it will explode.
- Always remove all oil/grease in gearboxes. If exposed to heat, for example from a blow torch, the oil/grease will catch fire.
- When motors are removed from the robot, the robot will collapse if it is not properly supported before the motor is removed.
- A used robot does not have the same performance as on delivery. Springs, brakes, bearings, and other parts might be worn or broken.

9 Reference information

9.1 Introduction

General

This chapter includes general information, complementing the more specific information in the different procedures in the manual.

9 Reference information

9.2 Applicable standards

9.2 Applicable standards

General

The product is compliant with ISO 10218-1:2011, *Robots for industrial environments - Safety requirements - Part 1 Robots*, and applicable parts in the normative references, as referred to from ISO 10218-1:2011. In case of deviation from ISO 10218-1:2011, these are listed in the declaration of incorporation. The declaration of incorporation is part of the delivery.

Robot standards

Standard	Description
ISO 9283	Manipulating industrial robots – Performance criteria and related test methods
ISO 9787	Robots and robotic devices – Coordinate systems and motion nomenclatures
ISO 9946	Manipulating industrial robots – Presentation of characteristics

Other standards used in design

Standard	Description
IEC 60204-1	Safety of machinery - Electrical equipment of machines - Part 1: General requirements, normative reference from ISO 10218-1
IEC 61000-6-2	Electromagnetic compatibility (EMC) – Part 6-2: Generic standards – Immunity standard for industrial environments
IEC 61000-6-4	Electromagnetic compatibility (EMC) – Part 6-4: Generic standards – Emission standard for industrial environments
ISO 13849-1:2006	Safety of machinery - Safety related parts of control systems - Part 1: General principles for design, normative reference from ISO 10218-1
IEC 61340-5-1	Protection of electronic devices from electrostatic phenomena - General requirements

Region specific standards and regulations

Standard	Description
ANSI/RIA R15.06	Safety requirements for industrial robots and robot systems
ANSI/UL 1740	Safety standard for robots and robotic equipment
CAN/CSA Z 434-03	Industrial robots and robot Systems - General safety requirements
ANSI/ESD S20.20	Protection of Electrical and Electronic Parts, Assemblies and Equipment (Excluding Electrically Initiated Explosive Devices)
EN ISO 10218-1	Robots and robotic devices — Safety requirements for industrial robots — Part 1: Robots

9.3 Unit conversion

Converter table

Use the following table to convert units used in this manual.

Quantity	Units		
Length	1 m	3.28 ft.	39.37 in
Weight	1 kg	2.21 lb.	
Weight	1 g	0.035 ounces	
Pressure	1 bar	100 kPa	14.5 psi
Force	1 N	0.225 lbf	
Moment	1 Nm	0.738 lbf-ft	
Volume	1 L	0.264 US gal	

9 Reference information

9.4 Screw joints

9.4 Screw joints

General

This section describes how to tighten the various types of screw joints on ABB robots.

The instructions and torque values are valid for screw joints comprised of metallic materials and do *not* apply to soft or brittle materials.

UNBRAKO screws

UNBRAKO is a special type of screw recommended by ABB for certain screw joints. It features special surface treatment (Gleitmo as described below) and is extremely resistant to fatigue.

Whenever used, this is specified in the instructions, and in such cases, *no other type of replacement screw* is allowed. Using other types of screws will void any warranty and may potentially cause serious damage or injury.

Gleitmo treated screws

Gleitmo is a special surface treatment to reduce the friction when tightening the screw joint. It is recommended by ABB for M6-M20 screw joints. Screws treated with Gleitmo may be reused 3-4 times before the coating disappears. After this the screw must be discarded and replaced with a new one.

When handling screws treated with Gleitmo, protective gloves of nitrile rubber type should be used.

Generally, screws are lubricated with *Gleitmo 603* mixed with *Geomet 500* or *Geomet 702* in proportion 1:3. *Geomet* thickness varies according to screw dimensions, refer to the following.

Dimension	Lubricant	Geomet thickness
M6-M20 (any length except M20x60)	<i>Gleitmo 603 + Geomet 500</i>	3-5 µm
M6-M20 (any length except M20x60)	<i>Gleitmo 603 + Geomet 720</i>	3-5 µm
M20x60	<i>Gleitmo 603 + Geomet 500</i>	8-12 µm
M20x60	<i>Gleitmo 603 + Geomet 720</i>	6-10 µm

Screws lubricated in other ways

Screws lubricated with Molykote 1000 or Molykote P1900 should *only* be used when specified in the repair, maintenance or installation procedure descriptions.

In such cases, proceed as follows:

- 1 Apply lubricant to the screw thread.
- 2 Apply lubricant between the plain washer and screw head.
- 3 Screw dimensions of M8 or larger must be tightened with a torque wrench. Screw dimensions of M6 or smaller may be tightened without a torque wrench *if* this is done by trained and qualified personnel.

Continues on next page

Lubricant	Article number
Molykote 1000 (molybdenum disulphide grease)	3HAC042472-001
Molykote P1900 (molybdenum disulphide grease)	3HAC070875-001

Tightening torque

Before tightening any screw, note the following:

- Determine whether a **standard** tightening torque or **special** torque is to be applied. The **standard torques** are specified in the following tables. Any **special torques** are specified in the repair, maintenance or installation procedure descriptions. **Any special torque specified overrides the standard torque!**
- Use the *correct tightening torque* for each type of screw joint.
- Only use *correctly calibrated* torque keys.
- *Always tighten the joint by hand*, and never use pneumatic tools.
- Use the *correct tightening technique*, that is *do not* jerk. Tighten the screw in a slow, flowing motion.
- Maximum allowed total deviation from the specified value is **10%!**

Tightening torque for oil-lubricated screws with slotted or cross-recess head screws

The following table specifies the recommended standard tightening torque for *oil-lubricated screws with slotted or cross-recess head screws*.



Note

A special torque specified in the repair, maintenance or installation procedure overrides the standard torque.

Tightening torque for oil-lubricated screws with allen head screws

The following table specifies the recommended standard tightening torque for *oil-lubricated screws with allen head screws*.



Note

A special torque specified in the repair, maintenance or installation procedure overrides the standard torque.

Dimension	Tightening torque (Nm) Class 8.8, oil-lubricated	Tightening torque (Nm) Class 10.9, oil-lubricated	Tightening torque (Nm) Class 12.9, oil-lubricated
M5	6	-	-
M6	10	-	-
M8	24	34	40
M10	47	67	80
M12	82	115	140
M16	200	290	340
M20	400	560	670

Continues on next page

9 Reference information

9.4 Screw joints

Continued

Dimension	Tightening torque (Nm) Class 8.8, oil-lubricated	Tightening torque (Nm) Class 10.9, oil-lubricated	Tightening torque (Nm) Class 12.9, oil-lubricated
M24	680	960	1150

Tightening torque for lubricated screws (Molykote, Gleitmo or equivalent) with allen head screws
The following table specifies the recommended standard tightening torque for *screws lubricated with Molykote 1000, Gleitmo 603 or equivalent with allen head screws.*



Note

A special torque specified in the repair, maintenance or installation procedure overrides the standard torque.

Dimension	Tightening torque (Nm) Class 10.9, lubricated ⁱ	Tightening torque (Nm) Class 12.9, lubricated ⁱ
M5		8
M6		14
M8	28	35
M10	55	70
M12	96	120
M16	235	300
M20	460	550
M24	790	950

ⁱ Lubricated with Molykote 1000, Gleitmo 603 or equivalent

9.5 Weight specifications

Definition

In installation, repair, and maintenance procedures, weights of the components handled are sometimes specified. All components exceeding 22 kg (50 lbs) are highlighted in this way.

To avoid injury, ABB recommends the use of a lifting accessory when handling components with a weight exceeding 22 kg. A wide range of lifting accessories and devices are available for each manipulator model.

Example

Following is an example of a weight specification in a procedure:

Action	Note
 CAUTION The arm weighs 25 kg. All lifting accessories used must be sized accordingly.	

9 Reference information

9.6 Standard toolkit

9.6 Standard toolkit

General

All service (repairs, maintenance, and installation) procedures contains lists of tools required to perform the specified activity.

All special tools required are listed directly in the procedures while all the tools that are considered standard are gathered in the standard toolkit and defined in the following table.

This way, the tools required are the sum of the standard toolkit and any tools listed in the instruction.

Contents, standard toolkit

Qty	Tool	Rem.
1	Socket head cap 2-17 mm	
1	Torque wrench 0.3-45 Nm	
1	Torque wrench 11 Nm±1.1 Nm	For securing robot to foundation.
1	Ratchet head for torque wrench 1/2	
1	Hex socket head cap no. 2.5 socket 1/2" bit L=110 mm	
1	Hex socket head cap no. 2.5 socket 1/2" bit L=150 mm	
1	Small screwdriver	
1	T-handle with ball head	
1	Small cutting plier	
1	Plastic mallet	
1	Needle-nose plier	

9.7 Special tools

General

All service instructions contain lists of tools required to perform the specified activity. The required tools are a sum of standard tools, defined in the section [Standard toolkit on page 840](#), and of special tools, listed directly in the instructions and also gathered in this section.

Special tools



Note

If the replacing procedure is not listed in the table below, only standard tools are needed for the procedure.

Tools and equipment with spare part number: (These tools can be ordered from ABB)

-	24 VDC power supply
3HAC074119-001	Calibration tool box, Axis Calibration Delivered as a set of calibration tools. Required if Axis Calibration is the valid calibration method for the robot. ⁱ
-	Sonic tension meter Used for measuring the timing belt tension.
-	Dynamometer Used for measuring the timing belt tension.
3HAC073070-001	Special toolkit Includes Belt tension adjustment tool set, axis 1&2 and Belt tension adjustment tool set, stage two of axis 4.

ⁱ The robot is calibrated by either manual calibration or Axis Calibration at ABB factory before delivery. Always use the same calibration method as used at the factory. Information about valid calibration method is found on the calibration label or in the calibration menu on the FlexPendant. If no data is found related to standard calibration, manual calibration is used as default.

9 Reference information

9.8 Lifting accessories and lifting instructions

9.8 Lifting accessories and lifting instructions

General

Many repair and maintenance activities require different pieces of lifting accessories, which are specified in each procedure.

The use of each piece of lifting accessories is *not* detailed in the activity procedure, but in the instruction delivered with each piece of lifting accessories.

The instructions delivered with the lifting accessories should be stored for later reference.

10 Spare parts

10.1 Spare part lists and illustrations

Location

Spare parts and exploded views are not included in the manual but delivered as a separate document for registered users on myABB Business Portal, www.abb.com/myABB.



Tip

All documents can be found via myABB Business Portal, www.abb.com/myABB.

This page is intentionally left blank

Index

A

Absolute Accuracy, calibration, 773
 allergenic material, 26
 aluminum
 disposal, 830
 ambient humidity
 operation, 39
 storage, 39
 ambient temperature
 operation, 39
 storage, 39
 assembly instructions, 47
 assessment of hazards and risks, 26
 Axis Calibration, 797
 calibration tool
 article number, 800, 804
 examining, 800
 installation position, 802
 overview of method, 797
 procedure on FlexPendant, 804
 protective cover and protection plug, 802, 804

B

ball screw spline unit
 lubrication, 114
 batteries
 disposal, 830
 Brake power supply, faulty, 826
 brake releasing, 65
 brakes
 testing function, 34

C

cabinet lock, 27
 cabling between robot and controller, 84
 calibrating
 robot, 797
 roughly, 780
 calibrating robot, 797
 calibration
 Absolute Accuracy type, 772
 rough, 780
 standard type, 772
 verification, 819
 when to calibrate, 774
 calibration, Absolute Accuracy, 773
 calibration manuals, 773
 calibration marks, 775
 calibration position
 jogging to, 820
 scales, 775
 calibration scales, 775
 CalibWare, 772
 carbon dioxide extinguisher, 27
 cleaning, 97
 climbing on robot, 30
 Cold environments, 89
 connecting the robot and controller, cabling, 84

D

damaged bearings, 824
 dimensions
 robot, 74
 direction of axes, 779

E

environmental information, 830
 equipment, robot, 74
 ESD
 damage elimination, 45
 sensitive equipment, 45
 expected life, 96
 extra equipment, 74

F

faulty brake, 826
 fire extinguishing, 27
 fitting, equipment, 74
 FlexPendant
 jogging to calibration position, 820
 MoveAbsJ instruction, 820
 updating revolution counters, 795
 foundation
 requirements, 39

G

grease, 30
 disposal, 830

H

hanging
 installed hanging, 26
 hazard levels, 17
 hazardous material, 830
 height
 installed at a height, 26
 hot gearbox oil, 823–824
 hot surfaces, 30
 HRA, 26
 humidity
 operation, 39
 storage, 39

I

information labels location, 99
 inspecting
 information labels, 99
 robot cabling, 101
 timing belts, 111
 installation
 equipment, 74
 instructions for assembly, 47
 integrator responsibility, 26
 intervals for maintenance, 94

L

labels
 robot, 19
 leaking sealing, 823
 lifting
 robot, 57
 lifting accessory, 839
 limitation of liability, 15
 Lithium
 disposal, 830
 loads on foundation, 37
 lock and tag, 27
 lubricants, 30
 lubrication
 ball screw spline unit, 114

M

- maintenance intervals, 94
- maintenance schedule, 94
- mechanical stop
 - axis 1, 83
- mechanical stop location, 83
- mounting, equipment, 74
- MoveAbsJ instruction, 820

N

- national regulations, 26
- negative directions, axes, 779
- neodymium
 - disposal, 830
- noise, 824

O

- oil, 30
 - disposal, 830
- oil leaks, 823
- operating conditions, 39
- original spare parts, 15
- overfilled gearbox, 823

P

- pedestal
 - installed on pedestal, 26
- personnel
 - requirements, 16
- plastic
 - disposal, 830
- positive directions, axes, 779
- PPE, 16
- product standards, 834
- protection classes, 40
- protection type, 40
- protective equipment, 16
- protective wear, 16

R

- recycling, 830
- regional regulations, 26
- release brakes, 33
- replacements, report, 117
- replacing
 - mechanical stop
 - axis 1, 83
 - xx, 49, 64, 120, 136, 189, 214, 225, 377, 425, 444, 464, 525, 543
- report replacements, 117
- requirements on foundation, 39
- responsibility and validity, 15
- revolution counters
 - storing on FlexPendant, 795
 - updating, 780
- risk of burns, 30
- robot
 - dimensions, 74
 - equipment, fitting, 74
 - labels, 19
 - lifting, 57
 - protection class, 40
 - protection types, 40
 - symbols, 19
 - technical data, 37
- robot cabling
 - inspecting, 101

- rubber
 - disposal, 830

S

- safety
 - brake testing, 34
 - ESD, 45
 - fire extinguishing, 27
 - release robot axes, 33
 - signals, 17
 - signals in manual, 17
 - symbols, 17
 - symbols on robot, 19
 - test run, 56, 90
- safety devices, 27
- safety hazard
 - hydraulic system, 28
 - pneumatic system, 28
- safety signals
 - in manual, 17
- safety standards, 834
- scales on robot, 775
- schedule of maintenance, 94
- screw joints, 836
- securing, robot, 68
- securing the robot to foundation, attachment screws, 68
- shipping, 829
- signals
 - safety, 17
- speed
 - adjusting, 89
- stainless steel
 - disposal, 830
- standards, 834
 - ANSI, 834
 - CAN, 834
- start of robot in cold environments, 89
- steel
 - disposal, 830
 - storage conditions, 39
- symbols
 - safety, 17
- synchronization position, 780
- sync marks, 775
- system integrator requirements, 26

T

- technical data
 - robot, 37
- temperatures
 - operation, 39
 - storage, 39
- testing
 - brakes, 34
- timing belts
 - inspecting, 111
- torques on foundation, 37
- transportation, 829
- troubleshooting
 - safety, 35

U

- upcycling, 830
- updating revolution counters, 780
- users
 - requirements, 16

V

validity and responsibility, 15
velocity
 adjusting, 89
verifying calibration, 819

W

weight, 37
 robot, 61, 68

X

xx
 replacing, 49, 64, 120, 136, 189, 214, 225, 377, 425,
 444, 464, 525, 543

Z

zero position
 checking, 820



ABB AB

Robotics & Discrete Automation

S-721 68 VÄSTERÅS, Sweden

Telephone +46 10-732 50 00

ABB AS

Robotics & Discrete Automation

Nordlysvegen 7, N-4340 BRYNE, Norway

Box 265, N-4349 BRYNE, Norway

Telephone: +47 22 87 2000

ABB Engineering (Shanghai) Ltd.

Robotics & Discrete Automation

No. 4528 Kangxin Highway

PuDong New District

SHANGHAI 201319, China

Telephone: +86 21 6105 6666

ABB Inc.

Robotics & Discrete Automation

1250 Brown Road

Auburn Hills, MI 48326

USA

Telephone: +1 248 391 9000

abb.com/robotics