



P Series: INLINE – Solid Shaft Output

STOBER P Series ServoFit® Precision Planetary Gearheads feature HeliCamber® gearing and many other components which make them the most accurate and efficient planetary gearheads available. HeliCamber® gear technology provides minimum wear, low backlash and low noise.

P Series Advantages

- Backlash as low as 3 arcmins
- Readily attaches to any servo motor (IEC, NEMA, or customized motor plates*)
- 95 to 97% efficiency
- 5 year limited warranty (2 years on bearings, seals, etc.)
- Input RPM up to 8,000
- Quiet running
- Assembled in the U.S.A.

* Maximum 10 working days for custom motor mounting plates

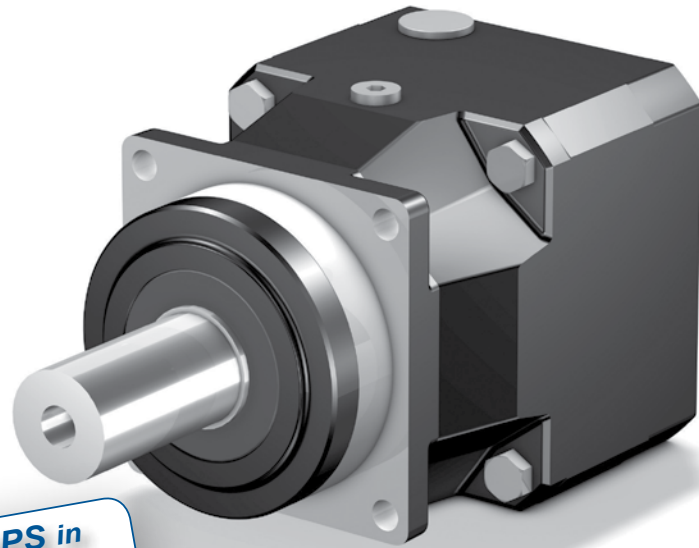

**SHIPS in
1 DAY!**
NO EXPEDITE FEE FOR
24 HOUR SERVICE

P Series Features

- 3:1 to 100:1 ratios
- Ring gear machined integral to the housing – not welded or pressed in – provides greater concentricity and eliminates speed fluctuation
- Highest running smoothness achieved by proven helical gearing and gear tooth microgeometry; gear quality provided by case-hardened and finish-ground sun and planet gears
- Magnetic oil filtration
- Bearing options for application specific radial load, axial load, and tilting moments
- The patented motor coupling is designed to allow thermal expansion of the motor shaft – ensuring long motor life by preventing thrust load on the motor bearings
- Motor plate can be easily changed to fit your choice of motors; pilot toleranced to fit your motor for precise concentricity
- Highest running accuracy and precision ensured by single piece housing
- Additional benefits of the one-piece housing are dissipating heat, noise dampening, and greater lubrication retention on the ring gear

Optional Features

ServoCool

- Used when a higher input speed is required or when improved performance and longer life is needed
- Reduces operating temperatures; helpful for applications with high ambient temperature
- Ideal for large planetary or units with small ratios

Large Input

- Accommodates a larger diameter motor shaft without going to a larger size gearbox

Coating Options

- **Standard:** For dry areas and normal conditions. All units standard coating, unless specifically ordered with one of the following:
- **Food:** Able to withstand severe wet areas and washdown application. For USDA compliant unit
- **Stainless Steel:** Able to withstand extremely harsh areas and washdown application. For USDA compliant unit

Overview





Selection Options *At-a-Glance*

P Series Gearheads are available in a wide range of user-selected design options that tailor the gearhead to your motor choice and exact application requirements. Use the appropriate order codes on the following pages to build a part number for the complete gearhead assembly.

Part Number Example:

P 4 2 1 S P R 0030 MT L

Design Option	Part Number Code	Description
Series	P	Solid shaft inline style planetary
Gearhead Size	2 3 4 5 7 8 9	7 sizes of gearhead
Generation	2	Version of gearhead
# of Stages	1 2	One stage for ratios of ≤ 10:1 Two stage for ratios >10:1
Housing	S	Standard mounting style
Output Shaft	P G	Shaft with key Plain shaft (no key)
Bearing Options		
	R	Ball bearing
	D	Double row angular contact bearing
	Z	Cylindrical roller bearing
Ratio	0030	Ratios range from 3:1 to 100:1 (0030=3:1; 0160=16:1; 1000=100:1, etc.)
Motor Adapter	MT AW	See motor mounting plate option Input shaft
Special Options	L C F	Large Input ServoCool Food Duty (size P3 thru P5)

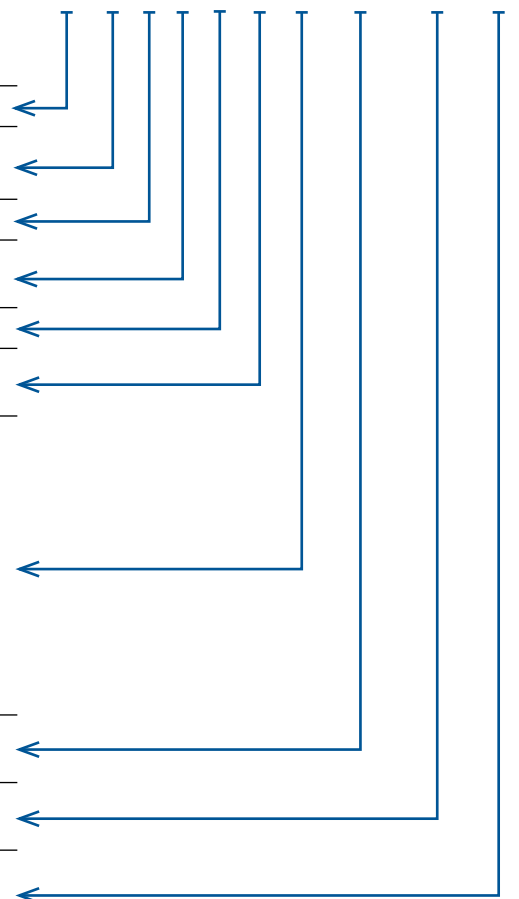

General Specifications

Efficiency	≥95 – 97%
Lubrication	Synthetic oil – lubricated for life
Degree of Protection	IP65 - FKM shaft seals (standard)
Mounting Position	Unrestricted
Installation	Requires grade 10.9 fasteners. See Gearhead Installation Notes, page 352, for more information
Direction of Rotation	Input and output rotate the SAME direction.
Ambient Temperature	0° C to +40°C (104° F) [Unit temperature ≤ 90° C Max.]
Coating	Standard Black (RAL 9005); food and stainless steel options available
Lifetime* Ln (hrs)	Ln > 10,000 hours if M2k/M2A < 1.25 and > 1.00 Ln > 20,000 hours if M2k/M2A > 1.25 and < 1.50 Ln > 30,000 hours if M2k/M2A > 1.5
Warranty	5 Year Limited (2 Years on normal wear items: bearings, seals, etc.)

* M2A equals actual tilting moment of the application. See page 17 for calculation details.

P Series Performance Overview

P Series performance is dependent on several factors including duty cycle, bearing design, gearhead size and stage configuration, among others. Use the chart below for preliminary evaluation, then use the following performance chart and selection information on the following pages for specific performance sizing and selection.

Size/Generation		P22		P32		P42		P52		P72		P82		P92	
# of Stages		1	2	1	2	1	2	1	2	1	2	1	2	1	2
Acceleration Torque M_{2BMAX}	Nm	22		65		120		300		700		1600		3000	
	in.lbs	195		575		1052		2655		6195		14,160		26,570	
Output Torque Nom. M_{2N}	Nm	16		45		85		210		440		1000		2000	
	in.lbs	142		399		753		1860		3898		8858		17,716	
Torsional Stiffness C_2	Nm/arcmin	1.9		5		11		33		55		176		350	340
	in.lbs/arcmin	17		44		100		266		486		1557		3094	3016
Torsional Backlash $\Delta\phi$	arcmin	≤6	≤8	≤4	≤5	≤4	≤5	≤3	≤4	≤3	≤4	≤3	≤4	≤3	≤4
Input Speed Max. n_{1MAX}	Continuous	4500	4500	4500	4500	4000	4500	3700	4000	3300	3700	2800	3300	2500	2800
	Cyclic	8000	8000	8000	8000	7000	8000	6500	7000	6000	6500	4500	6000	4000	4500
With ServoCool Option	Continuous	—	—	—	—	4500	—	5500	4500	5000	5000	4500	4500	4000	4000
	Cyclic	—	—	—	—	7000	—	6500	7000	6000	6500	6000	6000	5000	6000
Efficiency (@nom torque)	%	97	95	97	95	97	95	97	95	97	95	97	95	97	95
Weight	kg	1.2	1.8	2.6	3.5	4.0	5.3	6.5	8.5	12	15	26	32	50	61
	lbs	3	4	6	8	9	12	14	19	27	33	57	71	110	135
Noise ³⁾	dB(A)	≤61	≤61	≤61	≤61	≤62	≤60	≤63	≤61	≤64	≤62	≤65	≤63	≤65	≤64

Performance by Bearing Design Option ⁴⁾ (R = Ball bearing D = Double row angular contact bearing Z = Cylindrical roller bearing)

Size/Generation		P22	P32	P42	P52	P72	P82	P92	
Axial Load Max. F_{2AMAX}	R	N lbs	500 112	1000 225	1500 337	2300 518	2900 653	4700 1058	6000 1350
	D	N lbs	—	1400 315	2250 506	3500 788	4500 1013	7500 1688	10,000 2250
	Z	N lbs	—	600 135	1000 225	1600 360	2000 450	3600 810	5000 1125
Radial Load Max. F_{2RMAX}	R	N lbs	1200 270	2500 563	4000 900	6500 1463	8000 1800	13,000 2925	18,000 4050
	D	N lbs	—	2750 619	4500 1013	7000 1575	9000 2025	15,000 3375	20,000 4500
	Z	N lbs	—	3000 675	5000 1125	8000 1800	10,000 2250	18,000 4050	27,000 6075
Tilting Moment Max. M_{2KMAX}	R	Nm in.lbs	34 300	88 779	160 1416	338 2991	536 4774	897 5938	1665 14,735
	D	Nm in.lbs	—	105 929	194 1717	406 3593	648 5735	1140 10,089	2070 18,320
	Z	Nm in.lbs	—	105 929	200 1770	416 3682	670 5929	1242 10,992	2500 22,125

¹⁾ Ratings based on input speed (n_1) of 2000 RPM.

For torque at higher input speeds (M_{2NX}) solve the formula:
where n_1 = Actual Input Speed.

$$M_{2NX} = \frac{M_{2N}}{\sqrt[3]{\frac{n_1}{2000}}}$$

²⁾ Tested at 1.5% of nominal torque and recorded on the output side of the gearhead. For reduced value see the PA Series.

³⁾ Measurement at one (1) meter distance with input speed (n_1) of 2000 RPM.

⁴⁾ See page 16 for output bearing options. Rating based on output speed (n_2) of 100 RPM. For values at other speeds see page 17.

Overview



P Series Motor Mounting Plate Option (Motor information required with Motor Adapter MT option)

STOBER ServoFit Gearheads fit the motor of your choice with the appropriate motor mounting plate assembled between the motor and the gearhead.

NOTE: When ordering a gearhead:

- Specify the motor manufacturer and part number
- Provide the motor drawing with dimensions, or specify the motor mounting dimensions (per the list shown at right)

For a precise dimension on a specific motor, or for general assistance, we recommend you contact STOBER Technical Support.

Customer Required Dimensions for Properly Sized Motor Mounting Plate

D ⁶	Motor Shaft Diameter (If an adapter bushing is required it will be supplied with the motor plate.)
D ⁷	Pilot Diameter
D ⁸	Bolt Circle Diameter
D ⁹	Bolt Diameter
L ¹¹	Motor Shaft Length
L ¹²	Pilot Length
L ¹⁴	Square Flange (Optional – motor plate will typically be made to match this dimension.)

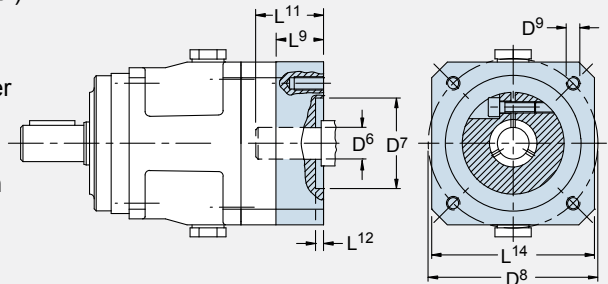

Motor Mounting Plate Dimensions — mm (Gearhead Part Number Specific)

	P221 P222 P322	P221...L P222...L P321 P322...L P422	P321...L P421 P422...L P522	P421...L P521 P522...L P722	P521...L P721 P722...L P822	P721...L P821 P822...L P922	P821...L P921 P922...L
Maximum Allowed Motor Shaft Dia. D ⁶	14	19	24	32	38	48	60
Minimum Allowed Motor Plate Thickness L ^{9*}	15	18	21	24	25	33	43

* Note that the L⁹ motor plate thickness is determined by the motor shaft length. The minimum motor plate thickness is the value listed.

P Series Output Shaft Options (“P” or “G” designated in part number, for example: P421S P0160 MTL)

P Shaft with Key

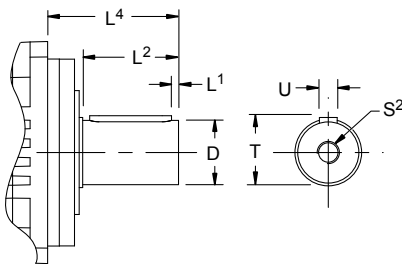

Unit	D k6 mm	L ¹		L ²		L ⁴		S ² (1)	T		U (2) W x H x L	
		mm	in	mm	in	mm	in		mm	in		
P2	12	+0.012/+0.001	2	0.08	22	0.87	36	1.42	M4	13.5	0.53	A4x4x18
P3	16	+0.012/+0.001	2	0.08	28	1.10	48	1.89	M5	18.0	0.71	A5x5x22
P4	22	+0.015/+0.002	3	0.11	36	1.42	56	2.20	M8	24.5	0.96	A6x6x28
P5	32	+0.018/+0.002	3	0.11	58	2.28	88	3.46	M12	35.0	1.38	A10x8x50
P7	40	+0.018/+0.002	4	0.16	82	3.23	112	4.41	M16	43.0	1.69	A12x8x70
P8	55	+0.021/+0.002	6	0.24	82	3.23	112	4.41	M20	59.0	2.32	A16x10x70
P9	75	+0.021/+0.002	7	0.28	105	4.13	143	5.63	M20	79.5	3.13	A20x12x90

G Shaft without Key

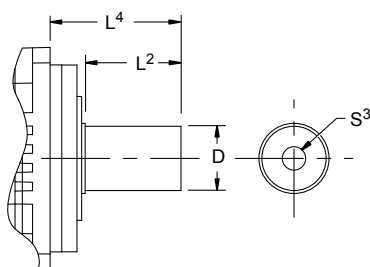

Unit	D k6 mm	L ²		L ⁴		S ³ (1)	
		mm	in	mm	in		
P2	12	+0.012/+0.001	22	0.87	36	1.42	M4
P3	16	+0.012/+0.001	28	1.10	48	1.89	M5
P4	22	+0.015/+0.002	36	1.42	56	2.20	M8
P5	32	+0.018/+0.002	58	2.28	88	3.46	M12
P7	40	+0.018/+0.002	82	3.23	112	4.41	M16
P8	55	+0.021/+0.002	82	3.23	112	4.41	M20
P9	75	+0.021/+0.002	105	4.13	143	5.63	M20

(1) The center hole in shafts with keys (Option “P”) are machined to DIN 332 T2 shape DR.

(2) Feather keys are tolerated according to standard DIN 6885.

P Series Output Bearing Options

R Ball Bearing

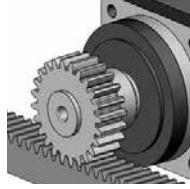

D Double Row Angular Contact Bearing

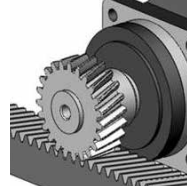

Z Cylindrical Roller Bearing

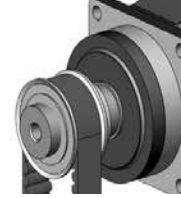

Characteristics:	<ul style="list-style-type: none"> Minimal frictional torque Good radial load capacity Axial load approx. 35% of radial load 	<ul style="list-style-type: none"> Low frictional torque Good radial bearing capacity Axial load approx. 50% of radial load 	<ul style="list-style-type: none"> Very good radial load capacity Axial load approx. 20% of radial load
Applications:	<ul style="list-style-type: none"> Spur geared rack/pinion Couplings Belt with or without light tension 	<ul style="list-style-type: none"> Helical geared rack/pinion Couplings with high axial load Belt with or without light tension 	<ul style="list-style-type: none"> Prestressed belt drive Prestressed spur rack drive Applications with high radial loads and/or high service requirements

No Load Running Torque*

Unit	Input Ratio T_R																	
	One Stage						Two Stage											
	3	4	5	7	8	10	15	16	20	25	28	32	35	40	50	70	100	
P2	Nm	—	0.2	0.2	0.2	0.2	0.1	—	0.1	0.1	0.1	0.1	0.1	0.1	0.1	0.1	0.1	0.1
	in.lbs	—	1.8	1.8	1.8	1.8	0.9	—	0.9	0.9	0.9	0.9	0.9	0.9	0.9	0.9	0.9	0.9
P3	Nm	0.3	0.2	0.2	0.2	0.2	0.1	0.1	0.1	0.1	0.1	0.1	0.1	0.1	0.1	0.1	0.1	0.1
	in.lbs	2.7	1.8	1.8	1.8	1.8	0.9	0.9	0.9	0.9	0.9	0.9	0.9	0.9	0.9	0.9	0.9	0.9
P4	Nm	0.4	0.3	0.3	0.2	0.2	0.2	0.1	0.1	0.1	0.1	0.1	0.1	0.1	0.1	0.1	0.1	0.1
	in.lbs	3.5	2.7	2.7	1.8	1.8	1.8	0.9	0.9	0.9	0.9	0.9	0.9	0.9	0.9	0.9	0.9	0.9
P5	Nm	0.8	0.6	0.5	0.4	0.3	0.3	0.3	0.3	0.3	0.2	0.2	0.2	0.2	0.2	0.2	0.2	0.2
	in.lbs	7.0	5.3	4.4	3.5	2.7	2.7	2.7	2.7	2.7	1.8	1.8	1.8	1.8	1.8	1.8	1.8	1.8
P7	Nm	0.9	0.7	0.6	0.5	0.4	0.4	0.3	0.3	0.3	0.2	0.2	0.2	0.2	0.2	0.2	0.2	0.2
	in.lbs	8.0	6.2	5.3	4.4	3.5	3.5	2.7	2.7	2.7	1.8	1.8	1.8	1.8	1.8	1.8	1.8	1.8
P8	Nm	1.6	1.3	1.1	0.9	0.7	0.7	0.3	0.6	0.5	0.5	0.4	0.4	0.4	0.4	0.4	0.4	0.4
	in.lbs	14.2	11.5	9.7	8.0	6.2	6.2	5.3	5.3	4.4	4.4	3.5	3.5	3.5	3.5	3.5	3.5	3.5
P9	Nm	—	2	2	2	—	1.25	—	1.25	1.25	1.25	1.25	—	1.25	1.25	1.25	1.25	1.25
	in.lbs	—	17.7	17.7	17.7	—	11	—	11	11	11	11	—	11	11	11	11	11

* Torque is measured with the input at 2000 RPM and an ambient temperature of 20° C.

Permissible Motor Tilting Torque

The permissible tilting torque of the motor attached to the gear unit is a result of the static and dynamic load "F" from the motor weight, mass acceleration, and vibration multiplied by the distance from the center of gravity "l_s" of the motor.

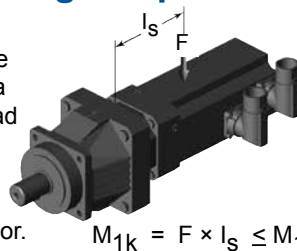

M_{1K}	P221 P222 P322	P321 P422	P421 P522	P521 P722	P721 P822	P821 P922	P921
Nm	10	20	40	80	200	400	800
in.lbs	88.5	177	354	708	1770	3540	7080

Overview



P
INLINE – Solid Shaft Output

Permissible Output Shaft Load and Tilting Moments*

Unit	Z ₂		F _{2A}		F _{2R}		F _{2RB}		M _{2K}		M _{2KB}	
	mm	in	N	lbs.	N	lbs.	N	lbs.	Nm	in.lbs	Nm	in.lbs
R Ball Bearing												
P2	17	0.669	500	112	1200	270	1300	293	34	300	36	319
P3	21	0.827	1000	225	2500	563	2500	563	88	779	88	779
P4	22	0.866	1500	337	4000	900	4500	1013	160	1416	180	1593
P5	23	0.906	2300	518	6500	1463	7000	1575	338	2708	364	3221
P7	26	1.023	2900	653	8000	1800	9000	2025	536	4744	603	5337
P8	28	1.102	4700	1058	13,000	2925	18,000	4050	897	7938	1242	10,992
P9	40	1.575	6000	1350	18,000	4050	27,000	6075	1665	14,735	2498	22,107
D Double Row Angular Contact Bearing												
P3	24	0.945	1400	315	2750	619	2750	619	105	929	105	929
P4	25	0.984	2250	506	4500	1013	5000	1125	194	1717	215	1903
P5	29	1.142	3500	788	7000	1575	8000	1800	406	3593	464	4106
P7	31	1.220	4500	1013	9000	2025	10000	2250	648	5735	720	6372
P8	35	1.378	7500	1688	15,000	3375	18,000	4050	1140	10,089	1368	12,107
P9	51	2.008	10,000	2250	20,000	4500	30,000	6750	2070	18,320	3105	27,479
Z Cylindrical Roller Bearing												
P3	21	0.83	600	135	3000	675	3000	675	105	929	105	929
P4	22	0.87	1000	225	5000	1125	5000	1125	200	1770	200	1770
P5	23	0.91	1600	360	8000	1800	8000	1800	416	3682	416	3682
P7	26	1.02	2000	450	10,000	2250	10,000	2250	670	5929	670	5929
P8	28	1.10	3600	810	18,000	4050	18,000	4050	1242	10,992	1242	10,992
P9	40	1.58	5000	1125	27,000	6075	35,000	7875	2500	22,125	3238	28,656

* Refer to illustration and definitions below.

During EMERGENCY OFF operation (maximum stops per gearhead = 1000) the permissible values in the table for F_{2A}, F_{2R} and M_{2K} can be multiplied by a factor of 2.

The permissible load values given are valid with the load applied to the center of the output shaft (x₂).

P Series Load/Life/Speed Calculations

The permissible load and tilting moment values are based on an output speed of 100 RPM. For higher speeds the following applies, where n₂ is the desired speed:

$$F_{2AX} = \frac{F_{2A}}{\sqrt[3]{\frac{n_2}{100}}} \quad F_{2RX} = \frac{F_{2R}}{\sqrt[3]{\frac{n_2}{100}}} \quad M_{2KX} = \frac{M_{2K}}{\sqrt[3]{\frac{n_2}{100}}}$$

The application input tilting moment should be determined by the following formula:

$$M_{2A} = \frac{2 \cdot F_{2a} \cdot y_2 + F_{2rb} \cdot (x_2 + z_2)}{1000} \leq M_{2KB}$$

$$M_{2ka} = \sqrt[3]{\frac{n_{2b1} \cdot t_{b1} \cdot M_{2kb1}^3 + \dots + n_{2bn} \cdot t_{bn} \cdot M_{2kbn}^3}{n_{2b1} \cdot t_{b1} + \dots + n_{2bn} \cdot t_{bn}}} \leq M_{2K}$$

$$F_{2r} = \sqrt[3]{\frac{n_{2b1} \cdot t_{b1} \cdot F_{2rb1}^3 + \dots + n_{2bn} \cdot t_{bn} \cdot F_{2rbn}^3}{n_{2b1} \cdot t_{b1} + \dots + n_{2bn} \cdot t_{bn}}} \leq F_{2R}$$

Where:

- | | |
|---|--|
| F_{2a} Axial Load at Output Shaft | M_{2K} Rated Tilting Torque |
| F_{2A} Permissible Axial Load | M_{2k} Equivalent Tilting Load |
| F_{2r} Radial Load at Output Shaft | M_{2KB} Acceleration Tilting Torque |
| F_{2R} Permissible Radial Load | z₂ Distance Factor |
| F_{2RB} Acceleration Permissible Radial Load | |

All formulas shown are based on METRIC values

Upper case letters are permissible values. Lower case letters are for existing values.

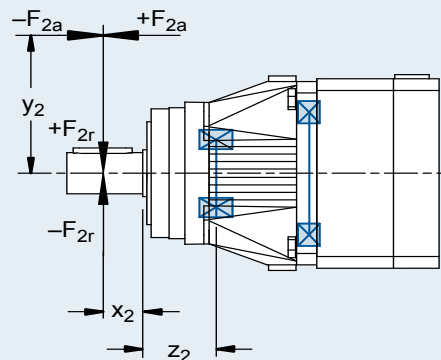

The hours of life (L_h) of the unit can be determined by the following formula:

bearing life for duty cycle ≤ 40%

$$L_h > 10,000 \text{ hours if } M_{2k}/M_{2A} < 1.25 \text{ and } > 1$$

$$L_h > 20,000 \text{ hours if } M_{2k}/M_{2A} > 1.25 \text{ and } > 1.5$$

$$L_h > 30,000 \text{ hours if } M_{2k}/M_{2A} < 1.5$$

bearing life for duty cycle ≥ 40%

$$L_{hA} = L_h \left(\frac{40\%}{\text{Duty Cycle}} \right)$$

P Series: INLINE – Solid Shaft Output

Exact Ratio (i)	Output Torque						Part Number* (Gearhead + Input)	Maximum Input Speed RPM (n1)		Motor Shaft Max Ø D ⁶ mm	Input Inertia ³⁾ J ₁ kgcm ²	Torsional Stiffness C ₂ (per arcmin)	
	Nominal ¹⁾ M _{2N}		Acceleration M _{2B}		Peak ²⁾ M _{2PEAK}			Cont.	Cyclic			Nm	in.lbs.
	Nm	in.lbs.	Nm	in.lbs.	Nm	in.lbs.							

P221 [55 mm sq.] One Stage

4.00	16	142	22	195	44	390	P221S_0040 MT	4500	8000	14	0.14	1.8	16.2
							P221S_0040 MTL						
5.00	16	142	22	195	44	390	P221S_0050 MT	4500	8000	14	0.12	1.9	16.4
							P221S_0050 MTL						
7.00	16	142	22	195	44	390	P221S_0070 MT	4500	8000	14	0.11	1.8	15.7
							P221S_0070 MTL						
8.00	14	124	18	159	36	319	P221S_0080 MT	4500	8000	14	0.10	1.7	14.9
							P221S_0080 MTL						
10.00	12	106	18	159	36	319	P221S_0100 MT	4500	8000	14	0.10	1.6	14.1
							P221S_0100 MTL						

P222 [55 mm sq.] Two Stage

16.00	16	142	22	195	44	390	P222S_0160 MT	4500	8000	14	0.14	1.8	15.8
							P222S_0160 MTL						
20.00	16	142	22	195	44	390	P222S_0200 MT	4500	8000	14	0.14	1.8	16.2
							P222S_0200 MTL						
25.00	16	142	22	195	44	390	P222S_0250 MT	4500	8000	14	0.12	1.8	16.2
							P222S_0250 MTL						
28.00	16	142	22	195	44	390	P222S_0280 MT	4500	8000	14	0.11	1.8	15.8
							P222S_0280 MTL						
32.00	14	124	18	159	36	319	P222S_0320 MT	4500	8000	14	0.13	1.7	14.8
							P222S_0320 MTL						
35.00	16	142	22	195	44	390	P222S_0350 MT	4500	8000	14	0.11	1.8	16.1
							P222S_0350 MTL						
40.00	16	142	22	195	44	390	P222S_0400 MT	4500	8000	14	0.10	1.8	15.7
							P222S_0400 MTL						
50.00	16	142	22	195	44	390	P222S_0500 MT	4500	8000	14	0.10	1.8	16.1
							P222S_0500 MTL						
70.00	16	142	22	195	44	390	P222S_0700 MT	4500	8000	14	0.10	1.8	15.6
							P222S_0700 MTL						
100.0	12	106	18	159	36	319	P222S_1000 MT	4500	8000	14	0.10	1.6	14.0
							P222S_1000 MTL						

¹⁾ Based on input speed of 2000 RPM. See page 14 for details on torque calculations at higher speed.

²⁾ Maximum momentary torque for emergency stops or heavy shock load. (Admissible stops per life of gearhead = 1,000 stops maximum.)

³⁾ Inertia based on maximum input. For lower inertia, using smaller diameter input, contact STOBER.

* MT = Motor Adapter L = Large Input Option

Selection Data



P
INLINE – Solid Shaft Output

Exact Ratio (i)	Output Torque						Part Number* (Gearhead + Input)	Maximum Input Speed RPM (n1)		Motor Shaft Max Ø D ⁶ mm	Input Inertia ³⁾ J ₁ kgcm ²	Torsional Stiffness C ₂ (per arcmin)	
	Nominal ¹⁾ M _{2N}		Acceleration M _{2B}		Peak ²⁾ M _{2PEAK}			Cont.	Cyclic			Nm	in.lbs.
	Nm	in.lbs.	Nm	in.lbs.	Nm	in.lbs.							
P321 [72 mm sq.] One Stage													
3.000	30	266	50	443	122	1083	P321S_0030 MT P321S_0030 MTL	3500	6000	19 24	0.77 1.45	5.7	50.5
4.000	45	399	65	576	130	1152	P321S_0040 MT P321S_0040 MTL	3700	6500	19 24	0.69 1.37	5.3	46.9
5.000	45	399	65	576	130	1152	P321S_0050 MT P321S_0050 MTL	4000	7000	19 24	0.64 1.32	5.1	45.2
7.000	45	399	60	531	130	1152	P321S_0070 MT P321S_0070 MTL	4500	8000	19 24	0.59 1.26	4.4	39.0
8.000	40	354	50	443	100	886	P321S_0080 MT P321S_0080 MTL	4500	8000	19 24	0.58 1.25	4.2	37.2
10.00	30	266	50	443	100	886	P321S_0100 MT P321S_0100 MTL	4500	8000	19 24	0.57 1.24	4.0	35.4

P322 [72 mm sq.] Two Stage													
15.00	30	266	50	443	122	1082	P322S_0150 MT P322S_0150 MTL	4500	8000	14 19	0.14 0.46	4.5	39.8
16.00	45	399	65	576	130	1152	P322S_0160 MT P322S_0160 MTL	4500	8000	14 19	0.14 0.61	4.5	39.8
20.00	45	399	65	576	130	1152	P322S_0200 MT P322S_0200 MTL	4500	8000	14 19	0.14 0.61	4.6	40.6
25.00	45	399	65	576	130	1152	P322S_0250 MT P322S_0250 MTL	4500	8000	14 19	0.12 0.59	4.6	40.6
28.00	45	399	65	576	130	1152	P322S_0280 MT P322S_0280 MTL	4500	8000	14 19	0.11 0.57	4.5	39.8
32.00	40	354	50	443	100	886	P322S_0320 MT P322S_0320 MTL	4500	8000	14 19	0.14 0.61	4.1	35.9
35.00	45	399	65	576	130	1152	P322S_0350 MT P322S_0350 MTL	4500	8000	14 19	0.11 0.57	4.6	40.6
40.00	45	399	65	576	130	1152	P322S_0400 MT P322S_0400 MTL	4500	8000	14 19	0.10 0.56	4.4	39.0
50.00	45	399	65	576	130	1152	P322S_0500 MT P322S_0500 MTL	4500	8000	14 19	0.10 0.56	4.5	39.8
70.00	45	399	60	531	130	1152	P322S_0700 MT P322S_0700 MTL	4500	8000	14 19	0.10 0.56	4.2	37.2
100.0	30	266	50	443	100	886	P322S_1000 MT P322S_1000 MTL	4500	8000	14 19	0.10 0.56	3.9	34.6

¹⁾ Based on input speed of 2000 RPM. See page 14 for details on torque calculations.

²⁾ Maximum momentary torque for emergency stops or heavy shock load. (Admissible stops per life of gearhead = 1,000 stops maximum.)

³⁾ Inertia based on maximum input. For lower inertia, using smaller diameter input, contact STOBBER.

* MT = Motor Adapter L = Large Input Option

P Series: INLINE – Solid Shaft Output

Exact Ratio (i)	Output Torque						Part Number* (Gearhead + Input)	Maximum Input Speed RPM (n1)		Motor Shaft Max Ø D ⁶ mm	Input Inertia ³⁾ J ₁ kgcm ²	Torsional Stiffness C ₂ (per arcmin)	
	Nominal ¹⁾ M _{2N}		Acceleration M _{2B}		Peak ²⁾ M _{2PEAK}			Cont.	Cyclic			Nm	in.lbs.
	Nm	in.lbs.	Nm	in.lbs.	Nm	in.lbs.							

P421 [98 mm sq.] One Stage

3.000	50	443	100	886	240	2126	P421S_0030 MT	3000	5500	24	1.94	12.5	110.7
							P421S_0030 MTC	3500	6000	24	2.66	11.1	98.3
							P421S_0030 MTL	3000	5500	32	4.16	12.5	110.7
4.000	85	753	120	1063	240	2126	P421S_0040 MT	3300		24	1.54	12.0	106.3
							P421S_0040 MTC	3800	6000	24	2.27	11.2	99.5
							P421S_0040 MTL	3300		32	3.77	12.0	106.3
5.000	85	753	120	1063	240	2126	P421S_0050 MT	3700		24	1.44	11.7	103.6
							P421S_0050 MTC	4200	6500	24	2.16	11.2	99.4
							P421S_0050 MTL	3700		32	3.66	11.7	103.6
7.000	85	753	110	974	240	2126	P421S_0070 MT	4000		24	1.31	10.1	89.5
							P421S_0070 MTC	4500	7000	24	2.05	9.9	87.8
							P421S_0070 MTL	4000		32	3.57	10.1	89.5
8.000	80	709	100	886	200	1772	P421S_0080 MT	4000		24	1.29	9.5	84.2
							P421S_0080 MTC	4500	7000	24	2.03	9.4	83.0
							P421S_0080 MTL	4000		32	3.55	9.5	84.2
10.00	60	531	100	886	200	1772	P421S_0100 MT	4000		24	1.27	9.0	79.7
							P421S_0100 MTC	4500	7000	24	2.01	8.9	79.1
							P421S_0100 MTL	4000		32	3.53	9.0	79.7

P422 [98 mm sq.] Two Stage

15.00	50	443	100	885	240	2124	P422S_0150 MT	3700	6500	19	0.52	10.4	92.2
							P422S_0150 MTL			24	1.07		
16.00	85	753	120	1063	240	2126	P422S_0160 MT	3700	6500	19	0.71	10.5	93.1
							P422S_0160 MTL			24	1.39		
20.00	85	753	120	1063	240	2126	P422S_0200 MT	3700	6500	19	0.70	10.8	95.2
							P422S_0200 MTL			24	1.38		
25.00	85	753	120	1063	240	2126	P422S_0250 MT	4000	7000	19	0.65	10.7	94.9
							P422S_0250 MTL			24	1.33		
28.00	85	753	120	1063	240	2126	P422S_0280 MT	4500	8000	19	0.60	10.3	90.8
							P422S_0280 MTL			24	1.27		
32.00	80	709	100	886	200	1772	P422S_0320 MT	3700	6500	19	0.69	9.2	81.9
							P422S_0320 MTL			24	1.37		
35.00	85	753	120	1063	240	2126	P422S_0350 MT	4500	8000	19	0.60	10.6	93.7
							P422S_0350 MTL			24	1.27		
40.00	85	753	120	1063	240	2126	P422S_0400 MT	4500	8000	19	0.58	10.1	89.5
							P422S_0400 MTL			24	1.25		
50.00	85	753	120	1063	240	2126	P422S_0500 MT	4500	8000	19	0.58	10.5	92.8
							P422S_0500 MTL			24	1.25		
70.00	85	753	110	974	240	2126	P422S_0700 MT	4500	8000	19	0.58	9.6	85.1
							P422S_0700 MTL			24	1.25		
100.0	60	531	100	886	200	1772	P422S_1000 MT	4500	8000	19	0.58	8.8	78.0
							P422S_1000 MTL			24	1.25		

¹⁾ Based on input speed of 2000 RPM. See page 14 for details on torque calculations.

²⁾ Maximum momentary torque for emergency stops or heavy shock load. (Admissible stops per life of gearhead = 1,000 stops maximum.)

³⁾ Inertia based on maximum input. For lower inertia, using smaller diameter input, contact STOBER.

* MT = Motor Adapter L = Large Input Option

Selection Data



P

INLINE – Solid Shaft Output

Exact Ratio (i)	Output Torque						Part Number* (Gearhead + Input)	Maximum Input Speed RPM (n1)		Motor Shaft Max Ø D ⁶ mm	Input Inertia ³⁾ J ₁ kgcm ²	Torsional Stiffness C ₂ (per arcmin)	
	Nominal ¹⁾ M _{2N}		Acceleration M _{2B}		Peak ²⁾ M _{2PEAK}			Cont.	Cyclic			Nm	in.lbs.
	Nm	in.lbs.	Nm	in.lbs.	Nm	in.lbs.							

P521 [115 mm sq.] One Stage

3.000	120	1063	200	1772	416	3686	P521S_0030 MT	2500	4500	32	4.76	36.3	321.5
							P521S_0030 MTC	3500	6000	32	6.98	29.7	262.7
							P521S_0030 MTL	2500	4500	38	7.79	36.3	321.5
4.000	210	1860	300	2657	555	4915	P521S_0040 MT	3000	5000	32	4.55	32.1	284.3
							P521S_0040 MTC	4000	6000	32	6.77	28.9	255.8
							P521S_0040 MTL	3000	5000	38	7.57	32.1	284.3
5.000	210	1860	300	2657	600	5315	P521S_0050 MT	3500		32	4.14	31.1	275.5
							P521S_0050 MTC	4500	6000	32	6.36	29.1	257.7
							P521S_0050 MTL	3500		38	7.16	31.1	275.5
7.000	210	1860	270	2392	600	5315	P521S_0070 MT	3700		32	3.74	28.0	248.0
							P521S_0070 MTC	4500	6500	32	5.98	27.1	240.4
							P521S_0070 MTL	3700		38	6.79	28.0	248.0
8.000	200	1772	250	2215	500	4429	P521S_0080 MT	3700		32	3.67	26.0	230.3
							P521S_0080 MTC	5000	6500	32	5.91	25.4	225.2
							P521S_0080 MTL	3700		38	6.72	26.0	230.3
10.00	140	1240	250	2215	500	4429	P521S_0100 MT	3700		32	3.61	25.0	221.5
							P521S_0100 MTC	5500	6500	32	5.85	24.7	218.4
							P521S_0100 MTL	3700		38	6.66	25.0	221.5

P522 [115 mm sq.] Two Stage

15.00	120	1062	200	1770	416	3683	P522S_0150MT	3300		24	1.22		
							P522S_0150MTC	3800	6000	24	2.29	27.3	241.5
							P522S_0150MTL	3300		32	3.13		
16.00	210	1860	300	2657	555	4915	P522S_0160 MT	3300		24	1.59	27.5	243.6
							P522S_0160 MTC	3800	6000	24	2.32	27.2	241.3
							P522S_0160 MTL	3300		32	3.82	27.5	243.6
20.00	210	1860	300	2657	600	5315	P522S_0200 MT	3300		24	1.57	28.2	249.6
							P522S_0200 MTC	3800	6000	24	2.29	28.0	248.0
							P522S_0200 MTL	3300		32	3.79	28.2	249.6
25.00	210	1860	300	2657	600	5315	P522S_0250 MT	3700		24	1.46	28.1	249.0
							P522S_0250 MTC	4200	6500	24	2.18	28.0	248.0
							P522S_0250 MTL	3700		32	3.68	28.1	249.0
28.00	210	1860	300	2657	555	4915	P522S_0280 MT	4000		24	1.34	26.8	237.2
							P522S_0280 MTC	4500	7000	24	2.08	26.7	236.5
							P522S_0280 MTL	4000		32	3.60	26.8	237.2
32.00	200	1772	250	2215	500	4429	P522S_0320 MT	3300		24	1.54	25.1	222.8
							P522S_0320 MTC	3800	6000	24	2.27	25.1	222.3
							P522S_0320 MTL	3300		32	3.76	25.1	222.8
35.00	210	1860	300	2657	600	5315	P522S_0350 MT	4000		24	1.33	27.7	245.3
							P522S_0350 MTC	4500	7000	24	2.07	27.6	244.8
							P522S_0350 MTL	4000		32	3.59	27.7	245.3
40.00	210	1860	300	2657	555	4915	P522S_0400 MT	4000		24	1.28	26.2	232.5
							P522S_0400 MTC	4500	7000	24	2.03	26.2	232.2
							P522S_0400 MTL	4000		32	3.55	26.2	232.5
50.00	210	1860	300	2657	600	5315	P522S_0500 MT	4000		24	1.28	27.3	242.0
							P522S_0500 MTC	4500	7000	24	2.02	27.3	241.8
							P522S_0500 MTL	4000		32	3.54	27.3	242.0
70.00	210	1860	270	2392	600	5315	P522S_0700 MT	4000		24	1.27	26.3	233.2
							P522S_0700 MTC	4500	7000	24	2.02	26.3	233.1
							P522S_0700 MTL	4000		32	3.54	26.3	233.2
100.0	140	1240	250	2215	500	4429	P522S_1000 MT	4000		24	1.27	24.3	215.5
							P522S_1000 MTC	4500	7000	24	2.02	24.3	215.4
							P522S_1000 MTL	4000		32	3.54	24.3	215.5

¹⁾ Based on input speed of 2000 RPM. See page 14 for details on torque calculations.

²⁾ Maximum momentary torque for emergency stops or heavy shock load. (Admissible stops per life of gearhead = 1,000 stops maximum.)

³⁾ Inertia based on maximum input. For lower inertia, using smaller diameter input, contact STÖBER.

* MT = Motor Adapter L = Large Input Option C = ServoCool

P Series: INLINE – Solid Shaft Output

Exact Ratio (i)	Output Torque						Part Number* (Gearhead + Input)	Maximum Input Speed RPM (n1)		Motor Shaft Max Ø D ⁶ mm	Input Inertia ³⁾ J ₁ kgcm ²	Torsional Stiffness C ₂ (per arcmin)	
	Nominal ¹⁾ M _{2N}		Acceleration M _{2B}		Peak ²⁾ M _{2PEAK}			Cont.	Cyclic			Nm	in.lbs.
	Nm	in.lbs.	Nm	in.lbs.	Nm	in.lbs.							

P721 [145 mm sq.] One Stage

3.000	280	2480	500	4429	1036	9177	P721S_0030 MT	2200	3700	38	14.81	64.5	571.3
							P721S_0030 MTC	3000	6000	38	26.04	54.7	484.5
							P721S_0030 MTL	2200	3700	48	32.66	64.5	571.3
4.000	440	3898	700	6201	1381	12,235	P721S_0040 MT	2500	4500	38	10.09	60.0	531.5
							P721S_0040 MTC	3300	6000	38	21.33	54.9	485.9
							P721S_0040 MTL	2500	4500	48	27.94	60.0	531.5
5.000	440	3898	700	6201	1400	12,401	P721S_0050 MT	3000	5500	38	8.55	57.5	509.3
							P721S_0050 MTC	3800	6000	38	19.79	54.4	481.6
							P721S_0050 MTL	3000	5500	48	26.40	57.5	509.3
7.000	440	3898	650	5758	1256	11,127	P721S_0070 MT	3300		38	7.55	55.0	487.2
							P721S_0070 MTC	4500	6000	38	18.46	53.1	470.7
							P721S_0070 MTL	3300		48	25.86	55.0	487.2
8.000	400	3543	500	4429	1000	8858	P721S_0080 MT	3300		38	7.29	53.0	469.5
							P721S_0080 MTC	5000	6000	38	18.20	51.7	457.7
							P721S_0080 MTL	3300		48	25.60	53.0	469.5
10.00	300	2657	500	4429	1000	8858	P721S_0100 MT	3300		38	7.05	49.5	438.1
							P721S_0100 MTC	5000	6000	38	17.95	48.7	431.8
							P721S_0100 MTL	3300		48	25.35	49.5	438.1

P722 [145 mm sq.] Two Stage

15.00	280	2478	500	4429	1036	9168	P722S_0150 MT	3000	5000	32	3.04		
							P722S_0150 MTC	4000	6000	32	5.56	53.1	470.7
							P722S_0150 MTL	3000	5000	38	6.76		
16.00	440	3898	700	6201	1381	12,235	P722S_0160 MT	3000	5000	32	4.63	53.7	475.9
							P722S_0160 MTC	4000	6000	32	6.85	53.1	470.7
							P722S_0160 MTL	3000	5000	38	7.66	53.7	475.9
20.00	440	3898	700	6201	1400	12,401	P722S_0200 MT	3000	5000	32	4.54	53.7	475.3
							P722S_0200 MTC	4000	6000	32	6.76	53.3	471.8
							P722S_0200 MTL	3000	5000	38	7.57	53.7	475.3
25.00	440	3898	700	6201	1400	12,401	P722S_0250 MT	3500		32	4.14	53.5	474.3
							P722S_0250 MTC	4500	6000	32	6.36	53.3	472.0
							P722S_0250 MTL	3500		38	7.17	53.5	474.3
28.00	440	3898	700	6201	1381	12,235	P722S_0280 MT	3700		32	3.83	52.9	468.7
							P722S_0280 MTC	4500	6500	32	6.07	52.7	466.9
							P722S_0280 MTL	3700		38	6.88	52.9	468.7
32.00	400	3543	500	4429	1000	8858	P722S_0320 MT	3000		32	4.46	51.7	457.7
							P722S_0320 MTC	4000	5000	32	6.68	51.5	456.4
							P722S_0320 MTL	3000		38	7.49	51.7	457.7
35.00	440	3898	700	6201	1400	12,401	P722S_0350 MT	3700		32	3.80	53.1	470.7
							P722S_0350 MTC	4500	6500	32	6.04	53.0	469.5
							P722S_0350 MTL	3700		38	6.85	53.1	470.7
40.00	440	3898	700	6201	1381	12,235	P722S_0400 MT	3700		32	3.65	52.2	462.2
							P722S_0400 MTC	5000	6500	32	5.90	52.1	461.3
							P722S_0400 MTL	3700		38	6.70	52.2	462.2
50.00	440	3898	700	6201	1400	12,401	P722S_0500 MT	3700		32	3.64	52.7	466.9
							P722S_0500 MTC	5000	6500	32	5.88	52.6	465.9
							P722S_0500 MTL	3700		38	6.69	52.7	466.9
70.00	440	3898	650	5758	1256	11,127	P722S_0700 MT	3700		32	3.63		
							P722S_0700 MTC	5000	6500	32	5.87	52.6	466.3
							P722S_0700 MTL	3700		38	6.68		
100.00	300	2657	500	4429	1000	8858	P722S_1000 MT	3700		32	3.62		
							P722S_1000 MTC	5000	6500	32	5.86	48.5	429.8
							P722S_1000 MTL	3700		38	6.67		

¹⁾ Based on input speed of 2000 RPM. See page 14 for details on torque calculations.

²⁾ Maximum momentary torque for emergency stops or heavy shock load. (Admissible stops per life of gearhead = 1,000 stops maximum.)

³⁾ Inertia based on maximum input. For lower inertia, using smaller diameter input, contact STOBER.

* MT = Motor Adapter L = Large Input Option C = ServoCool

Selection Data



P
INLINE – Solid Shaft Output

Exact Ratio (i)	Output Torque						Part Number* (Gearhead + Input)	Maximum Input Speed RPM (n1)		Motor Shaft Max Ø D ⁶ mm	Input Inertia ³⁾ J ₁ kgcm ²	Torsional Stiffness C ₂ (per arcmin)	
	Nominal ¹⁾ M _{2N}		Acceleration M _{2B}		Peak ²⁾ M _{2PEAK}			Cont.	Cyclic			Nm	in.lbs.
	Nm	in.lbs.	Nm	in.lbs.	Nm	in.lbs.							
P821 [190 mm sq.] One Stage													
3.000	800	7086	1200	10,630	1926	17,064	P821S_0030 MT	1800	3000	48	65.03	220.0	1948.8
							P821S_0030 MTC	2500	4500	48	86.28	165.4	1464.9
							P821S_0030 MTL	1800	3000	60	92.59	201.7	1787.0
4.000	800	7086	1600	14,173	2569	22,752	P821S_0040 MT	2200	3500	48	41.18	205.0	1815.9
							P821S_0040 MTC	3000	5000	48	62.44	174.7	1547.9
							P821S_0040 MTL	2200	3500	60	68.75	195.7	1733.6
5.000	1000	8858	1600	14,173	3200	28,346	P821S_0050 MT	2500	4000	48	34.36	194.0	1718.5
							P821S_0050 MTC	3500	6000	48	55.62	175.6	1555.4
							P821S_0050 MTL	2500	4000	60	57.31	188.6	1670.4
7.000	1000	8858	1400	12,401	2811	24,900	P821S_0070 MT	2800	4500	48	29.23	176.5	1563.4
							P821S_0070 MTC	4000	6000	48	50.96	167.0	1478.9
							P821S_0070 MTL	2800	4500	60	57.24	174.2	1542.9
8.000	800	7086	1200	10,630	2400	21,259	P821S_0080 MT	2800	4500	48	27.99	166.2	1472.2
							P821S_0080 MTC	4500	6000	48	49.72	159.6	1413.9
							P821S_0080 MTL	2800	4500	60	56.00	164.6	1458.2
10.00	700	6201	1200	10,630	2400	21,259	P821S_0100 MT	2800	4500	48	26.82	153.0	1355.3
							P821S_0100 MTC	4500	6000	48	48.55	149.4	1323.1
							P821S_0100 MTL	2800	4500	60	54.84	152.1	1347.6

P822 [190 mm sq.] Two Stage													
15.00	800	7086	1200	10,620	1926	17,049	P822S_0150 MT	2500	4500	38	8.65	166.2	1470.7
							P822S_0150 MTC	3300	6000	38	11.85		
							P822S_0150 MTL	2500	4500	48	26.63		
16.00	800	7086	1600	14,173	3200	28,346	P822S_0160 MT	2500	4500	38	10.65	168.9	1496.4
							P822S_0160 MTC	3300	6000	38	21.89	166.2	1472.1
							P822S_0160 MTL	2500	4500	48	28.50	168.9	1496.4
20.00	1000	8858	1600	14,173	3200	28,346	P822S_0200 MT	2500	4500	38	10.22	171.8	1521.7
							P822S_0200 MTC	3300	6000	38	21.46	170.0	1505.5
							P822S_0200 MTL	2500	4500	48	28.07	171.8	1521.7
25.00	1000	8858	1600	14,173	3200	28,346	P822S_0250 MT	3000	5500	38	8.83	170.9	1514.1
							P822S_0250 MTC	3800	6000	38	20.07	169.8	1503.8
							P822S_0250 MTL	3000	5500	48	26.68	170.9	1514.1
28.00	800	7086	1600	14,173	3200	28,346	P822S_0280 MT	3300		38	7.81	166.3	1472.8
							P822S_0280 MTC	4300	6000	38	18.71	165.2	1463.1
							P822S_0280 MTL	3300		48	26.11	166.3	1472.8
32.00	800	7086	1200	10,630	2400	21,259	P822S_0320 MT	2500	4500	38	9.85	159.3	1411.1
							P822S_0320 MTC	3300	6000	38	21.09	158.7	1405.7
							P822S_0320 MTL	2500	4500	48	27.70	159.3	1411.1
35.00	1000	8858	1600	14,173	3200	28,346	P822S_0350 MT	3300		38	7.67	170.0	1506.0
							P822S_0350 MTC	4300	6000	38	18.58	169.3	1499.5
							P822S_0350 MTL	3300		48	25.97	170.0	1506.0
40.00	800	7086	1600	14,173	3200	28,346	P822S_0400 MT	3300		38	7.17	162.8	1442.5
							P822S_0400 MTC	4500	6000	38	18.08	162.3	1437.9
							P822S_0400 MTL	3300		48	25.47	162.8	1442.5
50.00	1000	8858	1600	14,173	3200	28,346	P822S_0500 MT	3300		38	7.10	167.7	1485.6
							P822S_0500 MTC	4500	6000	38	18.01	167.4	1482.5
							P822S_0500 MTL	3300		48	25.40	167.7	1485.6
70.00	1000	8858	1400	12,401	2811	24,900	P822S_0700 MT	3300		38	7.06	164.5	1457.4
							P822S_0700 MTC	4500	6000	38	17.96	164.4	1455.9
							P822S_0700 MTL	3300		48	25.36	164.5	1457.4
100.0	700	6201	1200	10,630	2400	21,259	P822S_1000 MT	3300		38	7.03	148.4	1314.6
							P822S_1000 MTC	4500	6000	38	17.94	148.3	1314.0
							P822S_1000 MTL	3300		48	25.33	148.4	1314.6

¹⁾ Based on input speed of 2000 RPM. See page 14 for details on torque calculations.

²⁾ Maximum momentary torque for emergency stops or heavy shock load. (Admissible stops per life of gearhead = 1,000 stops maximum.)

³⁾ Inertia based on maximum input. For lower inertia, using smaller diameter input, contact STOBBER.

* MT = Motor Adapter L = Large Input Option C = ServoCool



P Series: INLINE – Solid Shaft Output

Exact Ratio (i)	Output Torque						Part Number* (Gearhead + Input)	Maximum Input Speed RPM (n1)		Motor Shaft Max Ø D ⁶ mm	Input Inertia ³⁾ J ₁ kgcm ²	Torsional Stiffness C ₂ (per arcmin)	
	Nominal ¹⁾ M _{2N}		Acceleration M _{2B}		Peak ²⁾ M _{2PEAK}			Cont.	Cyclic			Nm	in.lbs.
	Nm	in.lbs.	Nm	in.lbs.	Nm	in.lbs.							

P921 [225 mm sq.] One Stage

4.000	2000	17,716	3000	26,574	5432	48,117	P921S_0040 MT	2000	3000	60	98.17	349.3	3093.9
							P921S_0040 MTC	3000	4500		105.81		
5.000	2000	17,716	3000	26,574	6000	53,148	P921S_0050 MT	2200	3500	60	80.39	341.8	3027.4
							P921S_0050 MTC	3500	5000		88.03		
7.000	2000	17,716	2700	23,917	5400	47,833	P921S_0070 MT	2500	4000	60	67.08	322.0	2852.0
							P921S_0070 MTC	4000	5000		74.72		
10.00	1400	12,401	2000	17,716	4000	35,432	P921S_0100 MT	2500	4000	60	59.46	257.5	2281.1
							P921S_0100 MTC	4000	5000		67.09		

¹⁾ Based on input speed of 2000 RPM. See page 14 for details on torque calculations.

²⁾ Maximum momentary torque for emergency stops or heavy shock load. (Admissible stops per life of gearhead = 1,000 stops maximum.)

³⁾ Inertia based on maximum input. For lower inertia, using smaller diameter input, contact STOBER.

* MT = Motor Adapter C = ServoCool

Selection Data



P

INLINE – Solid Shaft Output

Exact Ratio (i)	Output Torque						Part Number* (Gearhead + Input)	Maximum Input Speed RPM (n1)		Motor Shaft Max Ø D ⁶ mm	Input Inertia ³⁾ J ₁ kgcm ²	Torsional Stiffness C ₂ (per arcmin)	
	Nominal ¹⁾ M _{2N}		Acceleration M _{2B}		Peak ²⁾ M _{2PEAK}			Cont.	Cyclic			Nm	in.lbs.
	Nm	in.lbs.	Nm	in.lbs.	Nm	in.lbs.							
P922 [225 mm sq.] Two Stage													
16.00	2000	17,716	3000	26,574	6000	53,148	P922S_0160 MT	2200	3500	48	42.16	340.5	3016.6
							P922S_0160 MTC	3000	5000	48	63.41	334.5	2963.3
							P922S_0160 MTL	2200	3500	60	69.72	338.9	3001.8
20.00	2000	17,716	3000	26,574	6000	53,148	P922S_0200 MT	2200	3500	48	41.04	336.4	2979.6
							P922S_0200 MTC	3000	5000	48	62.30	332.6	2946.1
							P922S_0200 MTL	2200	3500	60	68.61	335.3	2970.3
25.00	2000	17,716	3000	26,574	6000	53,148	P922S_0250 MT	2500	4000	48	34.78	335.1	2968.5
							P922S_0250 MTC	3500	6000	48	56.04	332.7	2947.2
							P922S_0250 MTL	2500	4000	60	62.35	334.5	2962.7
28.00	2000	17,716	3000	26,574	6000	53,148	P922S_0280 MT	2800	4500	48	29.81	334.9	2966.8
							P922S_0280 MTC	3750	5000	48	51.54	332.7	2946.8
							P922S_0280 MTL	2800	4500	60	57.82	334.4	2962.1
35.00	2000	17,716	3000	26,574	6000	53,148	P922S_0350 MT	2800	4500	48	29.45	332.8	2948.3
							P922S_0350 MTC	3750	6000	48	51.18	331.4	2935.7
							P922S_0350 MTL	2800	4500	60	57.46	332.5	2945.4
40.00	2000	17,716	3000	26,574	6000	53,148	P922S_0400 MT	2800	4500	48	26.78	328.9	2913.7
							P922S_0400 MTC	4000	6000	48	48.51	327.9	2904.3
							P922S_0400 MTL	2800	4500	60	54.79	328.7	2911.5
50.00	2000	17,716	3000	26,574	6000	53,148	P922S_0500 MT	2800	4500	48	26.60	329.0	2914.6
							P922S_0500 MTC	4000	6000	48	48.33	328.3	2908.5
							P922S_0500 MTL	2800	4500	60	54.61	328.9	2913.1
70.00	2000	17,716	2700	23,917	5400	47,833	P922S_0700 MT	2800	4500	48	26.47	316.1	2799.9
							P922S_0700 MTC	4000	6000	48	48.20	315.8	2797.0
							P922S_0700 MTL	2800	4500	60	54.48	316.0	2799.2
100.0	1400	12,401	2000	17,716	4000	35,432	P922S_1000 MT	2800	4500	48	26.39	255.7	2264.6
							P922S_1000 MTC	4000	6000	48	48.12	255.6	2263.7
							P922S_1000 MTL	2800	4500	60	54.40	255.6	2264.4

¹⁾ Based on input speed of 2000 RPM. See page 14 for details on torque calculations.

²⁾ Maximum momentary torque for emergency stops or heavy shock load. (Admissible stops per life of gearhead = 1,000 stops maximum.)

³⁾ Inertia based on maximum input. For lower inertia, using smaller diameter input, contact STOBBER.

* MT = Motor Adapter L = Large Input Option C = ServoCool

Standard Input

ServoCool Input Option

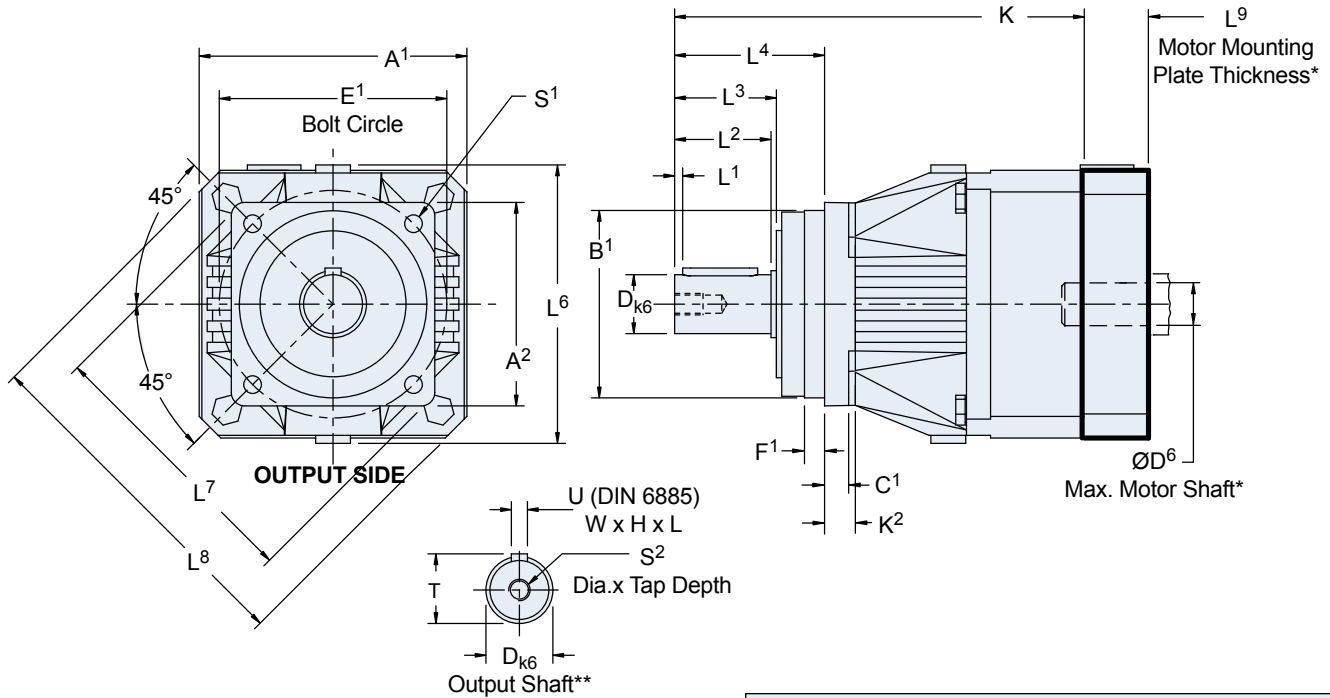

* See Motor Mounting Plate Option, page 15 for details.
** See Output Shaft Options, page 15 for details.

Table 1 Dimensions (mm)

Unit	A ¹	A ²	B ¹	h6	C ¹	D	k6	E ¹	F ¹	K ²
P221/P222	55	55	50	+0.000/-0.019	6	12	+0.012/+0.001	63	7	—
P321/P322	72	72	60	+0.000/-0.019	7	16	+0.012/+0.001	75	7.5	—
P421/P422	98	76	70	+0.000/-0.019	9	22	+0.015/+0.002	85	7.5	12
P521/P522	115	101	90	+0.000/-0.022	10	32	+0.018/+0.002	120	15	14
P721/P722	145	145	130	+0.000/-0.025	15	40	+0.018/+0.002	165	3.5	—
P821/P822	190	190	160	+0.000/-0.025	15	55	+0.021/+0.002	215	10	—
P921/P922	225	212	180	+0.000/-0.025	17	75	+0.021/+0.002	250	10	22

Table 2 Dimensions (mm)

Unit	L ¹	L ²	L ³	L ⁴	L ⁶	L ⁷	L ⁸	S ¹	S ²	T	U
P221/P222	2	22	24	36	62	74	80	5.5	M4x10	13.5	A4x4x18
P321/P322	2	28	30	48	79	92	92	5.5	M5x12.5	18	A5x5x22
P421/P422	3	36	38	56	98	103.3	130	6.6	M8x19	24.5	A6x6x28
P521/P522	3	58	60	88	121	139	149	9	M12x28	35	A10x8x50
P721/P722	4	82	85	112	145	—	190	11	M16x36	43	A12x8x70
P821/P822	6	82	85	112	190	—	250	13.5	M20x42	59	A16x10x70
P921/P922	7	105	109	143	225	285	300	17.5	M20x42	79.5	A20x12x90

Table 3 Dimensions (mm)

K	
Standard	ServoCool
P221 94.5	—
P222 126.5	—
P321 135	—
P322 158.5	—
P421 153	P421_C 176.5
P422 200.5	—
P521 193	P521_C 221
P522 242.5	P522_C 266
P721 242	P721_C 272
P722 294	P722_C 322
P821 283	P821_C 331
P822 350.5	P822_C 380.5
P921 353	P921_C 418
P922 441	P922_C 489



Dimensional Data

Large Input Option

P
INLINE – Solid Shaft Output

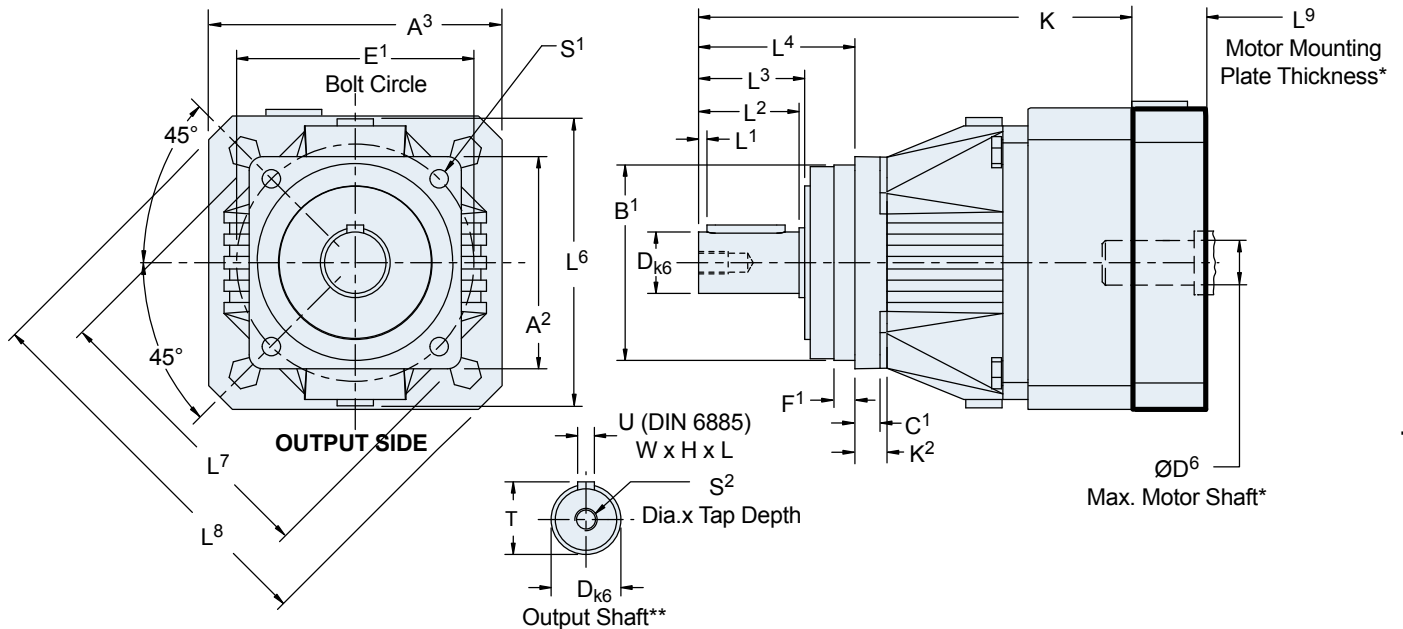

* See Motor Mounting Plate Option, page 15 for details.
 ** See Output Shaft Options, page 15 for details.

Table 1 Dimensions (mm)

Unit	A ²	B ¹	h6	C ¹	D	k6	E ¹	F ¹	K ²
P221/P222_L	55	50	+0.000/-0.019	6	12	+0.012/+0.001	63	7	—
P321/P322_L	72	60	+0.000/-0.019	7	16	+0.012/+0.001	75	7.5	—
P421/P422_L	76	70	+0.000/-0.019	9	22	+0.015/+0.002	85	7.5	12
P521/P522_L	101	90	+0.000/-0.022	10	32	+0.018/+0.002	120	15	14
P721/P722_L	145	130	+0.000/-0.025	15	40	+0.018/+0.002	165	3.5	—
P821/P822_L	190	160	+0.000/-0.025	15	55	+0.021/+0.002	215	10	—
P922_L	212	180	+0.000/-0.025	17	75	+0.021/+0.002	250	10	22

Table 3 Dimensions (mm)

Size	A ³	K	L ⁸
P221_L	75	111	100
P222_L	75	143	100
P321_L	100	138.3	130
P322_L	75	175	100
P421_L	115	161.5	149
P422_L	100	203.8	130
P521_L	145	207	190
P522_L	115	251	149
P721_L	190	259	250
P722_L	145	308	190
P821_L	225	291	300
P822_L	190	367.5	250
P922_L	225	449	300

Table 2 Dimensions (mm)

Unit	L ¹	L ²	L ³	L ⁴	L ⁶	L ⁷	S ¹	S ²	T	U
P221/P222_L	2	22	24	36	92	74	5.5	M4x10	13.5	A4x4x18
P321/P322_L	2	28	30	48	130	92	5.5	M5x12.5	18	A5x5x22
P421/P422_L	3	36	38	56	149	103.3	6.6	M8x19	24.5	A6x6x28
P521/P522_L	3	58	60	88	190	139	9	M12x28	35	A10x8x50
P721/P722_L	4	82	85	112	250	—	11	M16x36	43	A12x8x70
P821/P822_L	6	82	85	112	190	—	13.5	M20x42	59	A16x10x70
P922_L	7	105	109	143	225	285	17.5	M20x42	79.5	A20x12x90